

JBUS/MODBUS communication card

**Installation and user
manual**



Introduction

Thank you for selecting an MGE UPS SYSTEMS product to protect your electrical equipment.

The **JBUS/MODBUS** card has been designed with the utmost care. We recommend that you take the time to read this manual to take full advantage of the many features of your new equipment.

A lot of information about MGE UPS SYSTEMS products are available on our Web site www.mgeups.com.



Environment

MGE UPS SYSTEMS pays great attention to the environmental impact of its products during the design and manufacture stages, through to the end of its life cycle.

- ▶ This product complies with the most strict regulations.
- ▶ It does not contain CFCs or HCFCs.

Recycling of packing materials

Packing materials were selected to facilitate recycling. Please make sure they are correctly recycled in compliance with all applicable regulations.

Recycling of the product at the end of its life cycle

MGE UPS SYSTEMS undertakes to recycle all recovered products in installations, complying with applicable regulations. Please contact our sales office.



See the Environment section on our Web site at www.mgeups.com.

Special precautions

- ▶ If the card must be stored prior to installation, storage must be in a dry place.
- ▶ The admissible storage temperature range is -10° C to +70° C.

Foreword

Federal Communication Commission (FCC) statement

This equipment has been tested and found to comply with the limits for a Class A digital device, pursuant to part 15 of the FCC Rules. These limits are designed to provide reasonable protection against harmful interference when the equipment is operated in a commercial environment. This equipment generates, uses, and can radiate radio frequency energy and, if not installed and used in accordance with the instruction manual, may cause harmful interference to radio communications. Operation of this equipment in a residential area is likely to cause harmful interference in which case the user will be required to correct the interference at his own expense.

Pictograms used in this manual



Important operations to be done.



Information, advice, help.



Visual indication.



Action.

Contents

1. Presentation	
1.1 Unpacking and checking contents	6
1.2 Overview	7
1.3 Functions	8
1.4 Technical characteristics	8
2. Installation	
2.1 Setting the JBUS/MODBUS communication parameters	10
2.2 Return to the default JBUS/MODBUS parameters	12
2.3 RS232 link settings and connection	13
2.4 RS485 link settings and connection	14
2.5 Card installation	20
3. Operation	
3.1 In EX RT 5 / 7 / 11	21
3.2 In Pulsar EXTreme or Comet EXTreme	23
3.3 In Galaxy 3000	25
3.4 In Galaxy 5000	28
3.5 In Galaxy PW	31
3.6 In Upsilon STS	34
4. Troubleshooting	37

1. Presentation

1.1 Unpacking and checking contents

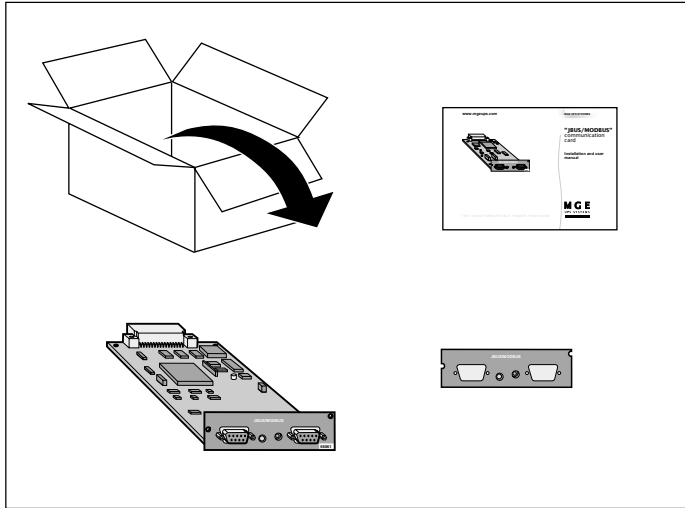

The product is made up of the following elements:

- ▶ **JBUS/MODBUS** communication card.
- ▶ A front plate specially designed for **Galaxy PW** UPSs (Uninterruptible Power Supply).
- ▶ Installation and user manual.

1. Presentation

1.2 Overview

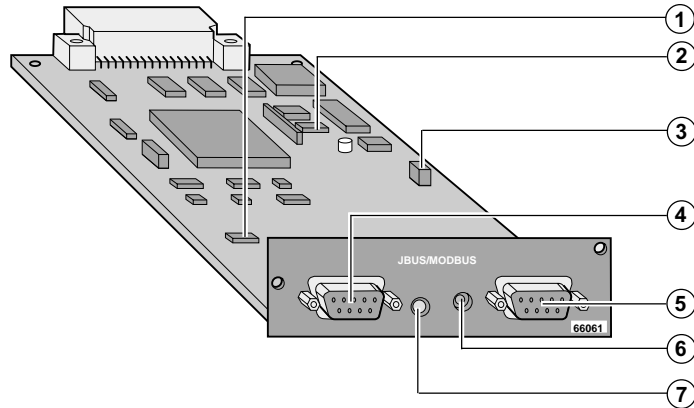

- ① Switches for RS485 settings (SA2).
- ② Switches for JBUS/MODBUS settings (SA1).
- ③ RS232 link configuration jumpers.
- ④ RS485 communication port.
- ⑤ RS232 communication port.
- ⑥ Diagnostic LED.
- ⑦ Card restart push button.

1. Presentation

1.3 Functions

The **JBUS/MODBUS** communication card provides **UPS** (Uninterruptible Power Supply) and **STS** (Static Transfer Switch) data (states and measures) to be sent a computer system.

The **JBUS** hexadecimal (MODBUS RTU) communication protocol is used in slave mode.

The system provides a communication channel with an RS485 or RS232 interface.



Note:

- ▶ The **JBUS/MODBUS** communication card may be used in all **UPSs** and **STSs** equipped with UPS BUS communication slots.
- ▶ Under specific constraints for a restricted use, the card can be inserted in a **MultiSlot** product. Please contact MGE UPS SYSTEMS Software Support to make sure your configuration is operational.
- ▶ 2 wires or 4 wires RS485 link are available.



Warning:

- ▶ RS232 and RS485 communication ports cannot be used together.
- ▶ **JBUS/MODBUS** communication is operational 2 minutes after the startup of the card.

1.4 Technical characteristics

Functions	Parameters	Default values	Possible values
JBUS/MODBUS communication	- Baud rate - Parity - Slave number	- 1200 bauds - without parity - Slave nr 1	- 1200, 2400, 4800, 9600 - Without parity, even parity - 1 to FF (hexadecimal)
RS232 link	- Link connection in transmit data (Tx) or receive data (Rx)	- Rx on pin 3 - Tx on pin 2	- Rx on pin 3 or on pin 2 - Tx on pin 2 or on pin 3
RS485 link	- Polarity - Termination	- No polarity - No termination	- With or without (2 or 4 wires) - With or without (2 or 4 wires)



Note: The **JBUS/MODBUS** communication format is 8 data bits and 1 stop bit. It is not configurable.

1. Presentation

JBUS Protocol

Detailed description of the **JBUS/MODBUS** protocol is available on our Web site www.mgeups.com

The standard **JBUS/MODBUS** functions provided by the card are:

- ▶ function 3 : read n words,
- ▶ function 5 : write 1 bit,
- ▶ function 6 : write 1 word,
- ▶ function 16 : write n words.

The data (states or measures) are stored in a sequential way in the **JBUS/MODBUS tables**.

In order to optimize the time to read data, it is recommended to access blocks of words to decrease the number of the **JBUS/MODBUS** requests.

All the JBUS responses are coded in 16 bits unsigned format except for the battery current which is signed, positive for the battery recharge and negative for the battery discharge.

2. Installation

2.1 Configuration of the JBUS/MODBUS communication parameters

If needed, it is possible to modify the default values of the **JBUS/MODBUS** communication parameters, following the actions below:

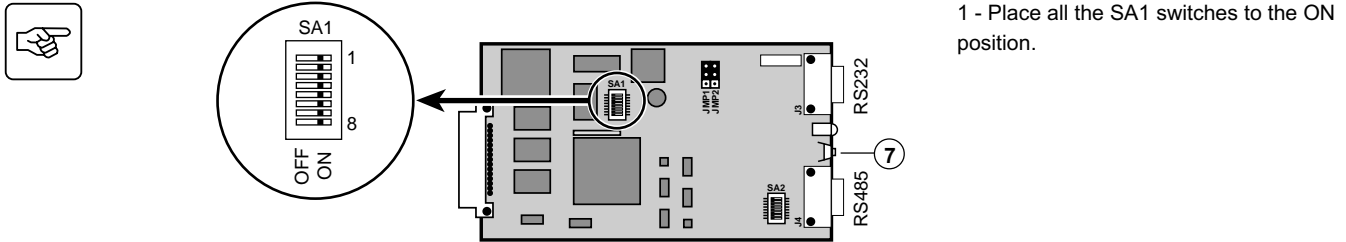

1 - Place all the SA1 switches to the ON position.

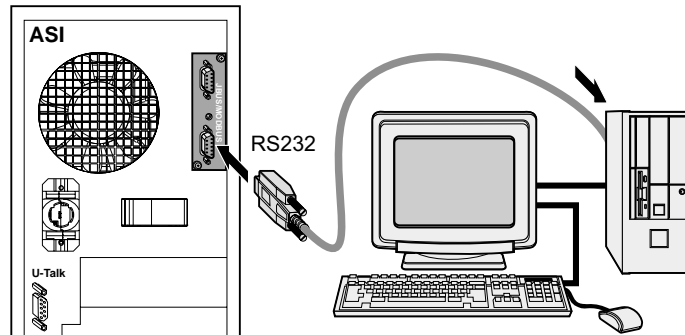

2 - Connect the RS232 link to a terminal (Microsoft Hyper terminal).

2. Installation



3 - Set the terminal with the following communication parameters: 9600 baud rate, even parity, 1 stop bit and 7 data bits, without flow control.

4 - Press the push button (7) more than 3 seconds on the card.

5 - Configuration mode is operational.

Check that the diagnostic LED (6) is blinking regularly twice per seconds.

A command prompt **CDE->** is displayed on the terminal screen.

6 - Enter the configuration command you need (see table below). Enter a carriage return ↵ after each command.

7 - When the required configuration is done, restart the board by pressing the push button (7) less than 3 seconds.

The card returns to operational mode, and the new **JBUS/MODBUS** parameters are up and running after 2 minutes.



Command	Function	Value to set
L	Reading current parameters.	None.
V	Baud rate setting.	1200 ↵ or 2400 ↵ or 4800 ↵ or 9600 ↵
P	Parity setting.	0 ↵ (wiyhout parity) or 2 ↵ (even parity).
E	Slave number setting.	from 1 ↵ to FF ↵ (hexadecimal).
M	Switching to echo mode.	None.



Note:

- ▶ The updated parameters are saved even if the card is turned off.
- ▶ In "eco" mode, characters typed in on the keyboard are displayed on the screen. This mode is available only during the configuration of the communication parameters.



Warning:

The communication parameters for the terminal are not configurable and not related to the **JBUS/MODBUS** communication parameters.

2. Installation

2.2 Return to the default JBUS/MODBUS parameters

To return to the default parameters (see §1.4) of the **JBUS/MODBUS** communication, you must:

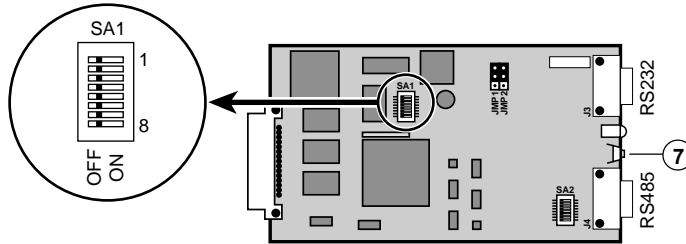

1 - Place all the SA1 switches to the OFF position.

2 - Press the push button **7** more than 3 seconds on the card.

3 - Release the button and restart the board by pressing the push button less than 3 seconds. The card returns to operational mode and the default **JBUS/MODBUS** parameters are up and running after 2 minutes.

2. Installation

2.3 RS232 link configuration and connection

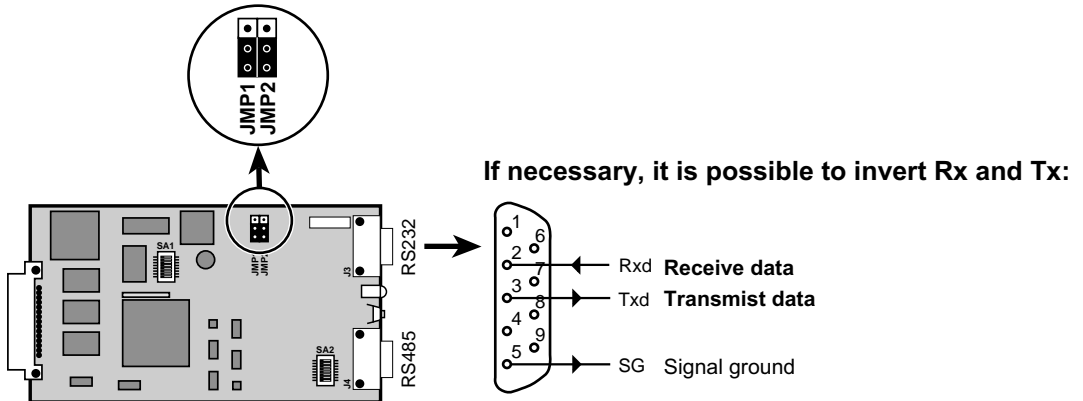
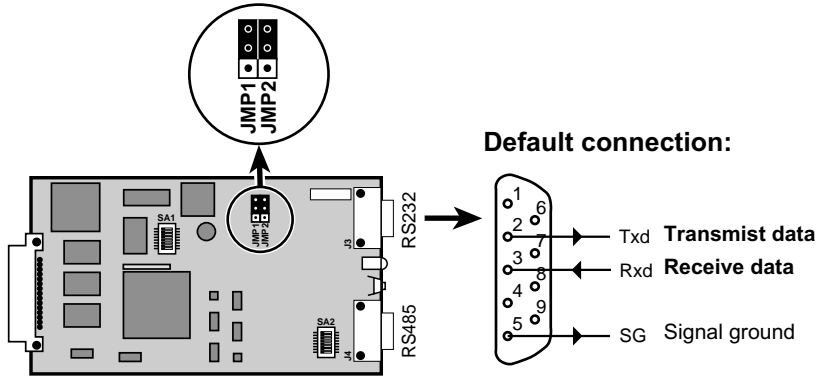

2. Installation

2.4 RS485 link configuration and connection

For proper operation, the polarity of EIA RS485 2-wire and 4-wire lines must be set at only one point and the lines terminated at the end.

Polarity

Normally, the master of the network sets the polarity of the line (Rp resistor).

Termination

The two ends of the line must be terminated (Ra resistor). Allow for 1 or 2 terminators to avoid mismatching the line when any equipment at the end of the line is disconnected.

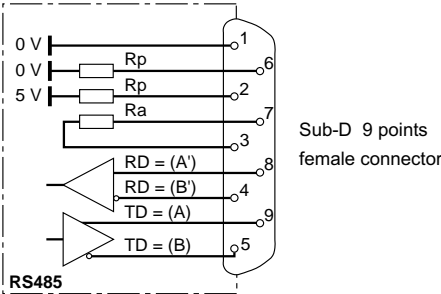

The default setting of the RS485 is a 4 wires configuration without polarity and without termination.

2. Installation

SA2 switches are used to make the termination and the polarity of the RS485 link:

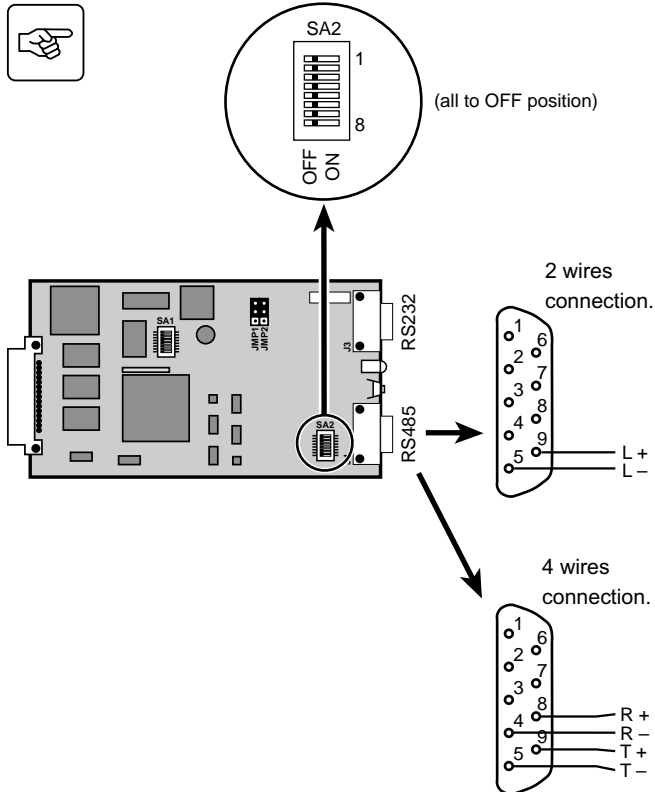

Polarity resistance = 332Ω

Termination resistance = 166Ω

1 : polarity T- (J4-5) to + 5V

2 : polarity T+ (J4-9) to 0V

3 : link termination T+ T-

4 : connection T- to R- (J4-5 to J4-4)

5 : connection T+ to R+ (J4-9 to J4-8)

6 : polarity R- (J4-4) to + 5 V

7 : polarity R+ (J4-6) to 0 V

8 : link termination R+ R-

2. Installation

Diagram of a 2-wire inter-cubicle connection

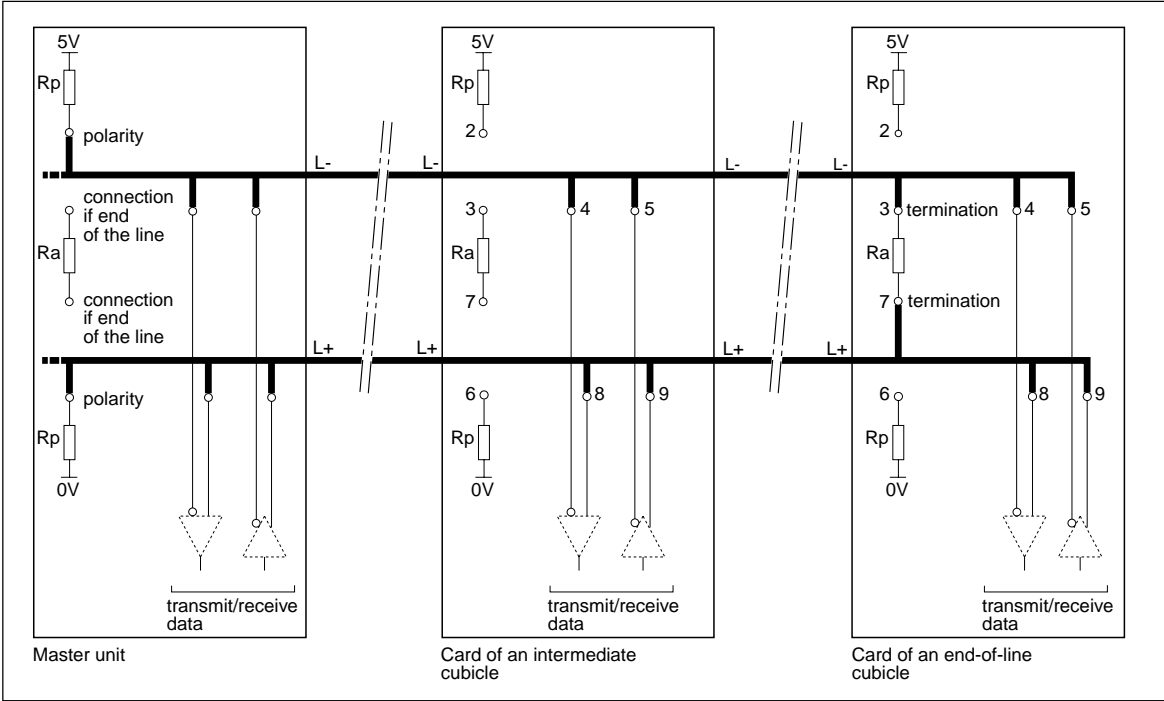

2. Installation

Card settings of an intermediate cubicle in 2 wires

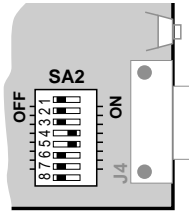

Link without polarity and without termination.

Card settings of an end of line cubicle in 2 wires

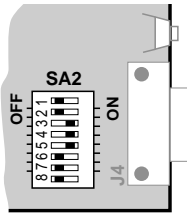

Link without polarity and with termination.

Others settings in 2 wires

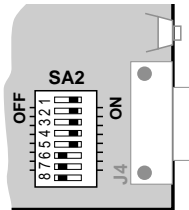

Link with polarity and with termination.

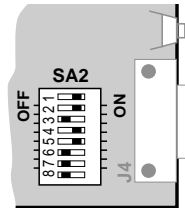

Link with polarity and without termination.

2. Installation

Diagram of a 4-wire inter-cubicle connection

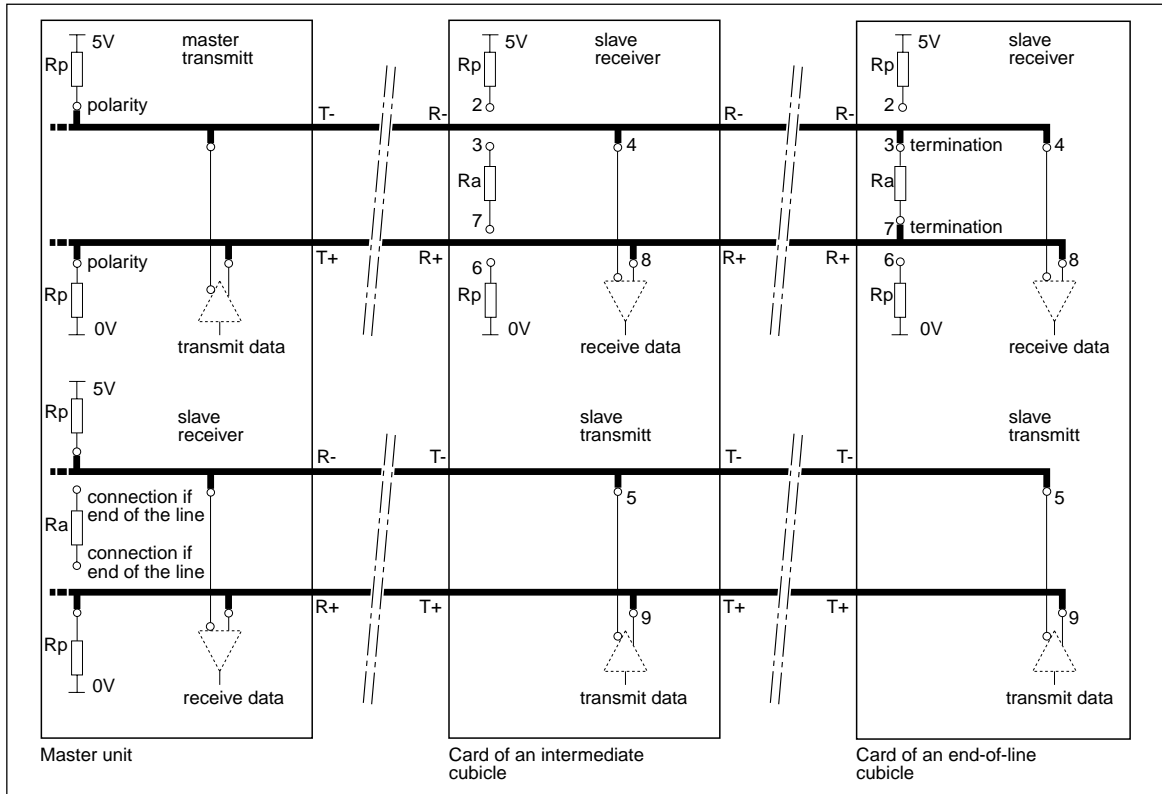

2. Installation

Card settings of an intermediate cubicle in 4 wires

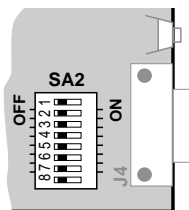

Link without polarity and without termination.

Card settings of an end of line cubicle in 4 wires

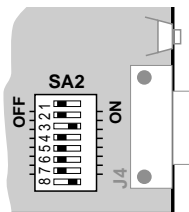

Link without polarity and with termination.

Others settings in 4 wires

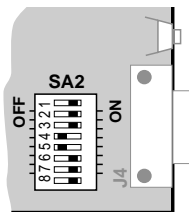

Link with polarity and with termination.

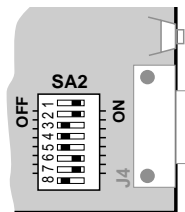

Link with polarity and without termination.

2. Installation

2.5 Card installation

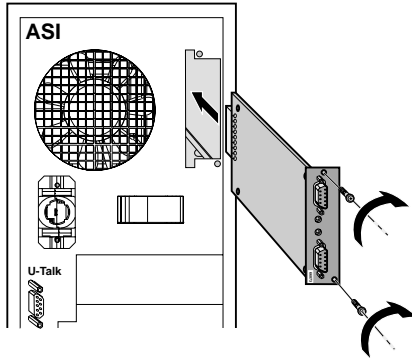

It is not necessary to turn the UPS or the STS off.

1. Using a screwdriver, remove the cover from a free slot in the UPS or in the STS.
2. Insert and secure the **JBUS/MODBUS** communication card in the UPS or in the STS.



Once the card has been inserted and connected, the diagnostic LED **⑥**:

- flashes regularly once per second during the start-up phase,
- flashes faster during initialization of the dialogue with the UPS or with the STS,
- flashes in step with the exchange of data with the UPS or with the STS.

Approximately 2 minutes after insertion, the JBUS/MODBUS communication is operational.

3. Operation

The **JBUS/MODBUS** communication card can be inserted in all products equipped with communication slots. For each of these products, data available through the **JBUS/MODBUS** protocol are listed in the tables below.

3.1 In EX RT 5 / 7 / 11

Status table

Status description	Status to 0	Status to 1	Word	Bit
Load protected	no	yes	40	0
UPS coupled	no	yes	40	1
Unit general alarm	no	yes	40	2
UPS in backup	no	yes	40	4
Battery low warning	no	yes	40	5
Operation on static switch	no	yes	40	7
Battery to be checked	no	yes	40	D
Device ventilation fault	no	yes	40	E
Eco mode allowed	no	yes	41	2
UPS in eco mode	no	yes	41	7
Mains 1 voltage out of tolerance	no	yes	44	8
Mains 1 frequency out of tolerance	no	yes	44	B
Mains 2 overload	no	yes	46	5
Mains 2 frequency out of tolerance	no	yes	46	9
Mains 2 voltage out of tolerance	no	yes	46	A
Phase M2 out of tolerance	no	yes	46	B
Charger general fault	no	yes	49	0
Battery charge	not in charge	in charge	49	3
Inverter major fault	no	yes	4C	1
Inverter overload	no	yes	4C	2
Output overload	no	yes	4F	0

3. Operation

Measurements table

Description of the physical quantity	Word	Unit
I mains 1	100	A
I mains 2	106	A
I output	109	A
I battery	10E	A
Device nominal active power	111	kW
U mains 1	115	V
U mains 2	121	V
U output	127	V
U battery	12D	V
Output active power	136	kW
Output apparent power	137	kVA
% output load level	139	(0-100)
Mains 1 frequency	13E	Hz
Mains 2 frequency	140	Hz
Output frequency	141	Hz
Battery backup time	149	mn
Battery charging level	14B	%
UPS rated power	209	kVA

3. Operation

3.2 In Pulsar EXtreme or Comet EXtreme

Status table

Status description	Status to 0	Status to 1	Word	Bit
Load protected	no	yes	40	0
UPS coupled	no	yes	40	1
Unit general alarm	no	yes	40	2
UPS in backup	no	yes	40	4
Battery low warning	no	yes	40	5
Operation on static switch	no	yes	40	7
Battery to be checked	no	yes	40	D
Mains 1 voltage out of tolerance	no	yes	44	8
Mains 1 frequency out of tolerance	no	yes	44	B
Maintenance position	no	yes	46	1
Mains 2 overload	no	yes	46	5
Charger general fault	no	yes	49	0
Battery charge	not in charge	in charge	49	3
Charger DC current fault	no	yes	4A	9
Inverter major fault	no	yes	4C	1
Inverter overload	no	yes	4C	2
Inverter thermal overload	no	yes	4C	3
Output thermal overload	no	yes	4D	F
Output overload	no	yes	4F	0
Output in short-circuit	no	yes	4F	1

3. Operation

Measurements table

Description of the physical quantity	Word	Unit
I mains 1	100	A
I output	109	A
U mains 1	115	V
U output	127	V
U battery	12D	V
Output apparent power	137	kVA
% output load level	139	(0-100)
Mains 1 frequency	140	Hz
Inverter frequency	13F	Hz
Output frequency	141	Hz
Battery backup time	149	mn
Battery charging level	14B	%
Battery recharge duration	14F	mn
UPS rated power	209	kVA

3. Operation

3.3 In Galaxy 3000

Status table

Status description	Status to 0	Status to 1	Word	Bit
Load protected	no	yes	40	0
UPS coupled	no	yes	40	1
Unit general alarm	no	yes	40	2
System downgraded operation	no	yes	40	3
UPS in backup	no	yes	40	4
Battery low warning	no	yes	40	5
End of backup time (voltage or time)	no	yes	40	6
Operation on static switch	no	yes	40	7
Emergency stop	no	yes	40	B
Device ventilation fault	no	yes	40	E
Manual bypass switch (Q3BP)	open	closed	41	6
Battery end of life	no	yes	42	1
Battery test result	battery test OK	battery test error	42	2
Battery compensation in progress	at rest	activated	42	5
Battery temperature out of tolerance	no	yes	42	A
Battery fuse fault	no	yes	42	B
Battery circuit-breaker (QF1)	open	closed	42	F
Rectifier normal on/off	rectifier off	rectifier on	44	2
Mains 1 input switch (Q1)	closed	open	44	3
Mains 1 voltage out of tolerance	no	yes	44	8
Mains 1 frequency out of tolerance	no	yes	44	B
Rectifier thermal overload	no	yes	44	C
Maintenance position	no	yes	46	1
Mains 2 overload	no	yes	46	5
Mains 2 thermal overload	no	yes	46	6

3. Operation

Status description	Status to 0	Status to 1	Word	Bit
Mains 2 frequency out of tolerance	no	yes	46	9
Mains 2 voltage out of tolerance	no	yes	46	A
Phase M2 out of tolerance	no	yes	46	B
Forced desynchronisation	no	yes	47	1
Bypass in free frequency	no	yes	47	8
Output switch (Q5N)	closed	open	47	B
Charger general fault	no	yes	49	0
Battery charged state	not charged	charged	49	3
Major UPS fault	no	yes	4C	1
Inverter overload	no	yes	4C	2
Inverter thermal overload	no	yes	4C	3
Inverter limitation	no	yes	4C	4
Output thermal overload	no	yes	4D	F
Output overload	no	yes	4F	0
Inverter fuse fault	no	yes	4C	5
Output in short-circuit	no	yes	4F	1

3. Operation

Measurements table

Description of the physical quantity	Word	Unit
I1 (I phase 1) mains 1	100	A
I2 (I phase 2) mains 1	101	A
I3 (I phase 3) mains 1	102	A
I1 (I phase 1) mains 2	106	A
I2 (I phase 2) mains 2	107	A
I3 (I phase 3) mains 2	108	A
I1 (I phase 1) output	109	A
I2 (I phase 2) output	10A	A
I3 (I phase 3) output	10B	A
I Battery	10E	A
Device nominal active power	111	kW
U12 mains 1	115	V
U23 mains 1	116	V
U31 mains 1	117	V
U1N inverter	118	V
U2N inverter	119	V
U3N inverter	11A	V
U12 mains 2	121	V
U23 mains 2	122	V
U31 mains 2	123	V
U1N output	124	V
U2N output	125	V
U3N output	126	V
U12 output	127	V

Description of the physical quantity	Word	Unit
U23 output	128	V
U31 output	129	V
U battery	12D	V
Output active power (phase 1)	130	kW
Output active power (phase 2)	131	kW
Output active power (phase 3)	132	kW
Output apparent power (phase 1)	133	kVA
Output apparent power (phase 2)	134	kVA
Output apparent power (phase 3)	135	kVA
Output total active power	136	kW
Output total apparent power	137	kVA
% output load level	139	(0-100)
Peak factor phase 1 x 100	13A	(0-400)
Peak factor phase 2 x 100	13B	(0-400)
Peak factor phase 3 x 100	13C	(0-400)
Power factor x 100	13D	(0-100)
Mains 1 frequency	13E	Hz
Inverter frequency	13F	Hz
Mains 2 frequency	140	Hz
Output frequency	141	Hz
Battery backup time	149	mn
Battery room temperature	14A	°C
Battery charging level	14B	%
Battery recharge duration	14F	mn
UPS rated power	209	kVA

3. Operation

3.4 In Galaxy 5000

Status table

Status description	Status to 0	Status to 1	Word	Bit
Load protected	no	yes	40	0
UPS coupled	no	yes	40	1
Unit general alarm	no	yes	40	2
System downgraded operation	no	yes	40	3
UPS in backup	no	yes	40	4
Battery low warning	no	yes	40	5
End of backup time (voltage or time)	no	yes	40	6
Operation on static switch	no	yes	40	7
Emergency stop	no	yes	40	B
UPS in "on-line" mode	no	yes	41	1
UPS in "eco" mode	no	yes	41	2
Unitary/parallel-connected UPS	no	yes	41	3
Manual bypass switch (Q3BP)	open	closed	41	6
Battery end of life	no	yes	42	1
Battery test result	battery test OK	battery test error	42	2
Battery automatic test in progress	no test in progress	test sequence activated	42	8
Battery temperature out of tolerance	no	yes	42	A
Battery circuit-breaker (QF1)	open	closed	42	F
Rectifier normal on/off	rectifier off	rectifier on	44	2
Mains 1 input switch (Q1)	closed	open	44	3
Mains 1 voltage out of tolerance	no	yes	44	8
Mains 1 frequency out of tolerance	no	yes	44	B
Rectifier thermal overload	no	yes	44	C
Maintenance position	no	yes	46	1
Mains 2 overload	no	yes	46	5
Mains 2 thermal overload	no	yes	46	6

3. Operation

Status description	Status to 0	Status to 1	Word	Bit
Mains 2 frequency out of tolerance	no	yes	46	9
Mains 2 voltage out of tolerance	no	yes	46	A
Phase M2 out of tolerance	no	yes	46	B
Mains 2 input switch (Q4S)	closed	open	46	E
Forced desynchronisation	no	yes	47	1
Output switch (Q5N)	closed	open	47	B
Number of UPS ready sufficient for coupling	no	yes	47	F
Charger general fault	no	yes	49	0
Battery charged state	not in charge	in charge	49	3
Major UPS fault	no	yes	4C	1
Inverter overload	no	yes	4C	2
Inverter thermal overload	no	yes	4C	3
Inverter limitation	no	yes	4C	4
Output thermal overload	no	yes	4C	5
Output overload	no	yes	4D	F
Inverter fuse fault	no	yes	4F	0
Output in short-circuit	no	yes	4F	1
End of warranty soon	no	yes	E	1
Battery check recommended	no	yes	E	3
Technical check recommended	no	yes	E	4
Technical check recommended	no	yes	E	5
Technical check recommended	no	yes	E	6
Technical check recommended	no	yes	E	7
Technical check recommended	no	yes	E	8

3. Operation

Measurements table

Description of the physical quantity	Word	Unit
I1 (I phase 1) mains 1	100	A
I2 (I phase 2) mains 1	101	A
I3 (I phase 3) mains 1	102	A
I1 (I phase 1) mains 2	106	A
I2 (I phase 2) mains 2	107	A
I3 (I phase 3) mains 2	108	A
I1 (I phase 1) output	109	A
I2 (I phase 2) output	10A	A
I3 (I phase 3) output	10B	A
I Battery	10E	A
Device nominal active power	111	kW
U12 mains 1	115	V
U23 mains 1	116	V
U31 mains 1	117	V
U1N inverter	118	V
U2N inverter	119	V
U3N inverter	11A	V
U12 mains 2	121	V
U23 mains 2	122	V
U31 mains 2	123	V
U1N output	124	V
U2N output	125	V
U3N output	126	V
U12 output	127	V

Description of the physical quantity	Word	Unit
U23 output	128	V
U31 output	129	V
U battery	12D	V
Output active power (phase 1)	130	kW
Output active power (phase 2)	131	kW
Output active power (phase 3)	132	kW
Output apparent power (phase 1)	133	kVA
Output apparent power (phase 2)	134	kVA
Output apparent power (phase 3)	135	kVA
Output total active power	136	kW
Output total apparent power	137	kVA
% output load level	139	(0-100)
Peak factor phase 1 x 100	13A	(0-400)
Peak factor phase 2 x 100	13B	(0-400)
Peak factor phase 3 x 100	13C	(0-400)
Power factor x 100	13D	(0-100)
Mains 1 frequency	13E	Hz
Inverter frequency	13F	Hz
Mains 2 frequency	140	Hz
Output frequency	141	Hz
Battery backup time	149	mn
Battery room temperature	14A	°C
Battery charging level	14B	%
Battery recharge duration	14F	mn
UPS rated power	209	kVA

3. Operation

3.5 In Galaxy PW

Status table

Status description	Status to 0	Status to 1	Word	Bit
Load protected	no	yes	40	0
UPS coupled	no	yes	40	1
Unit general alarm	no	yes	40	2
System downgraded operation	no	yes	40	3
UPS in backup	no	yes	40	4
Battery low warning	no	yes	40	5
End of backup time (voltage or time)	no	yes	40	6
Operation on static switch	no	yes	40	7
Emergency stop	no	yes	40	B
Device ventilation fault	no	yes	40	E
Protected shutdown on external contact	no	yes	40	F
UPS in on-line mode	no	yes	41	1
UPS in "eco" mode	no	yes	41	2
Unitary/parallel-connected UPS	no	yes	41	3
Status UPS ready for coupling	no	yes	41	4
Manual bypass switch (Q3BP)	open	closed	41	6
Battery end of life	no	yes	42	1
Battery test result	battery test OK	battery test error	42	2
Battery manual test in progress	no test in progress	test sequence activated	42	4
Battery compensation in progress	at rest	activated	42	5
Battery automatic test in progress	no test in progress	test sequence activated	42	8
Battery temperature out of tolerance	no	yes	42	A
Battery ventilation fault	no	yes	42	D
Battery circuit-breaker (QF1)	open	closed	42	F
Rectifier normal on/off	rectifier off	rectifier on	44	2

3. Operation

Status description	Status to 0	Status to 1	Word	Bit
Mains 1 input switch (Q1)	closed	open	44	3
Mains 1 voltage out of tolerance	no	yes	44	8
Mains 1 frequency out of tolerance	no	yes	44	B
Major coupling fault	no	yes	46	0
Maintenance position	no	yes	46	1
Mains 2 overload	no	yes	46	5
Mains 2 thermal overload	no	yes	46	6
Mains 2 frequency out of tolerance	no	yes	46	9
Mains 2 voltage out of tolerance	no	yes	46	A
Mains 2 phase out of tolerance	no	yes	46	B
Mains 2 input switch (Q4S)	closed	open	46	E
Bypass in free frequency	no	yes	47	8
Output switch (Q5N)	closed	open	47	B
Forced shutdown on external contact	no	yes	47	C
Number of UPS ready sufficient for coupling	no	yes	47	F
Charger general fault	no	yes	49	0
Battery charged state	not in charge	in charge	49	3
Major Inverter fault	no	yes	4C	1
Inverter overload	no	yes	4C	2
Inverter thermal overload	no	yes	4C	3
Inverter limitation	no	yes	4C	4
Inverter fuse fault	no	yes	4C	5
Output thermal overload	no	yes	4D	F
Output overload	no	yes	4F	0

3. Operation

Measurements table

Description of the physical quantity	Word	Unit
I1 (I phase 1) mains 1	100	A
I2 (I phase 2) mains 1	101	A
I3 (I phase 3) mains 1	102	A
I1 (I phase 1) inverter	103	A
I2 (I phase 2) inverter	104	A
I3 (I phase 3) inverter	105	A
I1 (I phase 1) mains 2	106	A
I2 (I phase 2) mains 2	107	A
I3 (I phase 3) mains 2	108	A
I1 (I phase 1) output	109	A
I2 (I phase 2) output	10A	A
I3 (I phase 3) output	10B	A
I Battery	10E	A
Device nominal active power	111	kW
U12 mains 1	115	V
U23 mains 1	116	V
U31 mains 1	117	V
U1N inverter	118	V
U2N inverter	119	V
U3N inverter	11A	V
U12 inverter	11B	V
U23 inverter	11C	V
U31 inverter	11D	V
U1N mains 2	11E	V
U2N mains 2	11F	V
U3N mains 2	120	V
U12 mains 2	121	V

Description of the physical quantity	Word	Unit
U23 mains 2	122	V
U31 mains 2	123	V
U1N output	124	V
U2N output	125	V
U3N output	126	V
U12 output	127	V
U23 output	128	V
U31 output	129	V
U battery	12D	V
Battery voltage end of backup threshold	12E	V
Output active power (phase 1)	130	kW
Output active power (phase 2)	131	kW
Output active power (phase 3)	132	kW
Output apparent power (phase 1)	133	kVA
Output apparent power (phase 2)	134	kVA
Output apparent power (phase 3)	135	kVA
Output total active power	136	kW
Output total apparent power	137	kVA
% output load level	139	(0-100)
Peak factor phase 1 x 100	13A	(0-400)
Peak factor phase 2 x 100	13B	(0-400)
Peak factor phase 3 x 100	13C	(0-400)
Power factor x 100	13D	(0-100)
Mains 1 frequency	13E	Hz
Inverter frequency	13F	Hz
Mains 2 frequency	140	Hz
Output frequency	141	Hz

3. Operation

Description of the physical quantity	Word	Unit
Nominal backup time	148	mn
Battery backup time	149	mn
Battery room temperature	14A	°C
Battery charging level	14B	%
Battery recharge duration	14F	mn

3.6 In Upsilon STS

In addition to the tables of data (states and measures) available for reading, there is a table for writing commands. If you need more information on this later table, in order to control the **Upsilon STS** through its **JBUS/MODBUS** communication, you should contact the software support team (contact available on our Web site www.mgeups.com).

Status table

Status description	Status to 0	Status to 1	Word	Bit
Source 1 input switch (Q1)	open	closed	1002	3
Source 2 input switch (Q2)	open	closed	1002	4
Output switch (Q3)	open	closed	1002	5
Source 1 bypass switch (Q1BP)	open	closed	1002	6
Source 2 bypass switch (Q2BP)	open	closed	1002	7
Source 1 active	no	yes	1002	8
Source 2 active	no	yes	1002	9
Source 1 preferred	no	yes	1002	A
Source 2 preferred	no	yes	1002	B
Load supplied	no	yes	1002	C
Source 1 out of tolerance	no	yes	1002	D

3. Operation

Status description	Status to 0	Status to 1	Word	Bit
Source 2 out of tolerance	no	yes	1002	E
Transfert valid	no	yes	1003	7
Source 1 phases inversion	no	yes	1003	8
Source 2 phases inversion	no	yes	1003	9
Prohibited transfert	no	yes	1003	A
Phase source 1/source 2 fault	no	yes	1000	0
Load supplying fault	no	yes	1000	5
EPO supplying fault	no	yes	1000	6
EPO activated fault	no	yes	1000	B
Thermal overload fault	no	yes	1001	1
Source 1 voltage fault	no	yes	1000	C
Source 2 voltage fault	no	yes	1000	D
Static Switch 1 fault	no	yes	1001	8
KM1 fault	no	yes	1001	9
Static Switch 2 fault	no	yes	1001	E
KM2 fault	no	yes	1001	F
Phase S1/S2 rotation fault	no	yes	1002	0
Source 1 frequency out of tolerance fault	no	yes	1002	1
Source 2 frequency out of tolerance fault	no	yes	1002	2
Overload fault	no	yes	1001	0
Internal fault	no	yes	1001	2
General Alarm fault	no	yes	1001	3

3. Operation

Measurements table

Description of the physical quantity	Word	Unit
U12 source 1	1100	V
U23 source 1	1101	V
U31 source 1	1102	V
U12 source 2	1103	V
U23 source 2	1104	V
U31 source 2	1105	V
I1 source 1	1106	A
I2 source 1	1107	A
I3 source 1	1108	A
I1 source 2	1109	A
I2 source 2	110A	A
I3 source 2	110B	A
Source 1 active power (ph 1)	110C	kW
Source 1 active power (ph 2)	110D	kW
Source 1 active power (ph 3)	110E	kW
Source 2 active power (ph 1)	110F	kW
Source 2 active power (ph 2)	1110	kW
Source 2 active power (ph 3)	1111	kW
Source 1 apparent power (ph 1)	1112	kVAR
Source 1 apparent power (ph 2)	1113	kVAR
Source 1 apparent power (ph 3)	1114	kVAR
Source 2 apparent power (ph 1)	1115	kVAR
Source 2 apparent power (ph 2)	1116	kVAR
Source 2 apparent power (ph 3)	1117	kVAR
U1N source 1	1118	V
U2N source 1	1119	V
U3N source 1	111A	V

Description of the physical quantity	Word	Unit
U1N source 2	111B	V
U2N source 2	111C	V
U3N source 2	111D	V
Source 1 neural current	1127	A
Source 2 neural current	1128	A
Source 1 frequency (ph 1)	1129	Hz
Source 2 frequency (ph 1)	112A	Hz
Phase source 1 / source 2	112B	Degré
Total active power	112C	kW
Total apparent power	112D	kVA
Total reactive power	112E	kVAR
% load level	112F	%
Power factor x 100	1130	(0-100)
Peak factor x 100	1131	(0-400)
Nominal voltage of sources	1135	V
Nominal frequency	1136	Hz
Nominal current	113A	A

4. Troubleshooting



Problem	Probable cause	Remedy
The diagnostic LED ⑥ remains always OFF.	The card is not supplied with power.	<ul style="list-style-type: none"> - Check that the card is correctly inserted and secured in its slot, - Check that the system is energised, - Remove the card and install it again.
The diagnostic LED ⑥ remains always ON.	The card is blocked.	<ul style="list-style-type: none"> - Check that the push button ⑦ is released (not pressed), - Remove the card and install it again.
JBUS/RS232 communication is not operational.	<ul style="list-style-type: none"> - Communication parameters are not correct. - The RS232 connection is faulty. 	<ul style="list-style-type: none"> - Wait 2 minutes after power on or card restart. - Check that the RS485 ④ and RS232 ⑤ ports are not both connected. - Check that the Rx/Tx ③ jumper position is in accordance with the serial cable used (see §2.3). - Check that the communication parameters used by the JBUS master application are in accordance with the card parameters. - Check the link with the default parameters (see §2.2).
JBUS/RS485 communication is not operational.	<ul style="list-style-type: none"> - Communication parameters are not correct. - The RS485 connection is faulty. 	<ul style="list-style-type: none"> - Wait 2 minutes after power on or card restart. - Check that the RS485 ④ and RS232 ⑤ ports are not both connected. - Check that the polarity and termination are corrects regarding the card position in the RS485 network (see §2.4). - Check that the communication parameters used by the JBUS master application are in accordance with the card parameters. - Check the link with the default parameters (see §2.2). - Validate the communication parameters by checking the card in point to point RS232 link.
The access of the configuration menu is impossible.	<ul style="list-style-type: none"> - The maintenance mode is not activated. - The RS232 connection is faulty. 	<ul style="list-style-type: none"> - Check the position of the SA1 ② switches (see §2.1) - Check that the Rx/Tx ③ jumper position is in accordance with the serial cable used (see §2.3). - Check the terminal settings: 9600 bauds, even, 7 data bits, 1 stop bit, - Press the push button ⑦ more than 3 seconds.

