

Delta UPS Protocol

Version 1.55p

1. Communication Parameters

Baud Rate 2400

Parity None

Data Bits 8

Stop Bits 1

1.1. Plug and Play

The standard string of Windows plug & play is:

```
HEX : 28 01 24 44 4c 54 30 30 30 31 5c 5c 5c 5c 55 50 53
      30 31 29
ASCII: (          D L T 0 0 0 1 \ \ \ \ U P S 0
        1 )
```

If you want to change the string, please inform UPS software engineer.

1.2. Acknowledgement Rule of End of Data Packet

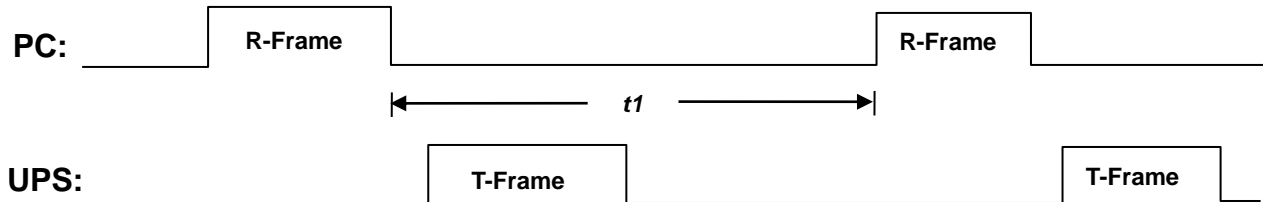

1. On PC side, a received time-out $t1$ is measured from the command packet sent to the UPS which equals to 1000 ms, points out that the received data package from UPS should be completed in 1 second.
2. If there are consecutive commands send to the UPS then only the first received command is going to parse and execute, the others should be ignored. After replying, the UPS then receives the new command from the PC and parses the first received command again.

2. Message Format

2.1 Regular Format

Header	ID	Type	Length	Data	Checksum
1 byte	2 bytes	1 byte	3 bytes	128 bytes max	2 bytes

2.1.1 Header

The header will be a '~' character.

2.1.2 ID

Default value is '00'.

2.1.3 Type

- R - Command rejected due to not support (UPS → Computer)
- A - Command accepted (UPS → Computer)
- P - Polling command (Computer → UPS)
- S - Set command (Computer → UPS)
- D - Data returned (UPS → Computer)

2.1.4 Length

The length is the number of bytes of data passed. 2 bytes of checksum is not included in the Length.

2.1.5 Data

All data will be separated by ';'. If a variable value is not currently available, a ';' with no data should be placed in the variable location.

2.1.6 Checksum

The total sum from Header to the end of Data in a byte (unsigned char) then transfer the byte number to a 2 digital hexadecimal characters. For example: If the checksum is 0x8e, the field value in Checksum would be '8' and 'E'.

2.2 Regular Format Example

2.2.1 Get the alarm status without checksum

PC -> UPS: ~00P003STA
UPS -> PC: ~00D0220;0;0;0;0;;;;;0;;;1

2.2.2 Get the battery status without checksum

PC -> UPS: ~00P003STB
UPS -> PC: ~00D0220;0;1;0;0;414;;28;100

2.2.3 Get the input information with checksum

PC -> UPS: ~00P003STIB1
UPS -> PC: ~00D0323;600;2200;;;600;2200;;;600;220046

2.2.4 Get the output information with checksum

PC -> UPS: ~00P003STOB7
UPS -> PC: ~00D0490;600;3;2200;10;220;5;2200;10;225;5;2200;10;223;5C4

3. Regular Format Messages

3.1 Polling Commands

Command	Description
General Commands	
AVL	Available Commands
AL1	Available commands 1

AL2	Available commands 2
AL3	Available commands 3
MNU	UPS Manufacturer
MOD	UPS Model Name
RAT	Rating(Nominal) Values
SDT	Shutdown Type
STB	Battery Status
STI	Input Status
STO	Output Status
STP	Bypass Status
STA	Alarm Status
TSR	Self Test Results
VER	UPS Firmware Version
TXV	Transfer Voltage
VSN	Voltage Sensitivity
LET	Number of Outlet Relay
SOL	Outlet Relay Status
BRD	Battery Replacement Date
ATT	Auto Test
ARB	AC Fail & Restore Auto-Reboot enable/disable
TXF	Transfer Bypass Frequency
UBD	UPS Boot Delay
BTV	Battery Test Time & Voltage
EPO	Emergency Power Off
CPU	Communication Protocol of the Unit
SER	Serial Number
DWR	UPS Shutdown Reason
AEL	Ask for UPS Event Log Type
EVT	Get the UPS Event Log by Index Number
ELS	Get the UPS Event Log by Segment Number
TME	Get the UPS Internal Time
CHS	Charger Steps
LOK	Get lock/unlock status
3Phase Commands	
ASR	Check SRAM Exist
SRS	Get the SRAM by Segment Number
SDC	Dry Contact Output Status for 3Phase
IDC	Dry Contact Input Status
STM	Temp Status (NT)
MID	Parallel Master ID (NT)
SST	Status for 3Phase UPS
PMA	Power Module Attribute
PMS	Power Module Status
PFS	Power Module PFC Status
PIS	Power Module Inverter Status
PCS	Power Module Charger Status

PMT	Power Module Temperature
PIV	Power Module Inverter Voltage
PIC	Power Module Inverter Current
PMV	Power Module main input Voltage
PMC	Power Module main input Current
BPA	Power Module Bypass
BT1	Get the Bypass Tx Voltage by method1
BT2	Get the Bypass Tx Voltage by method2
BCT	Battery Cabinet Temperature

3.1.1 AVL

Data: (UPS->Computer)

Name	Type	Range/Length	Comment
b0 b1 b2 b3 ... b20 b21	Integer	22	1 = Available 0 = Not supported

Description: b0: RNF, b1: ROF, b2: RON, b3: VSN, b4: TXV, b5: UID, b6: UBR, b7: TST, b8: SDT, b9: SDR, b10: SDA, b11: EMS, b12: BUZ, b13: ARB, b14: ATX, b15: BTT, b16: ATT, b17: ECO, b18: TXF, b19: UBD, b20: WDG, b21: EBP

This command must be supported to compatible with old applications, AL1~AL3 is optional if applicable.

3.1.2 AL1

Data(UPS->Computer)

Name	Type	Range/Length	Comment
b0 b1 b2 b3 b4 b5 b6 b7 b8 b9 b10 b11 b12 b13 b14 b15 b16 b17 b18 b19 b20 b21 b22 b23 b24	Integer	25	1=Available 0=Not Supported

Description: b0: AVL, b1: MNU, b2: MOD, b3: RAT, b4: SDT, b5: STB, b6: STI, b7: STO, b8: STP, b9: STA, b10: TSR, b11: UBR, b12: UID, b13: VER, b14: TXV, b15: VSN, b16: LET, b17: SOL, b18: TEL, b19: BRD, b20: ENV, b21:ATT, b22:ATX, b23:ARB, b24:TXF

3.1.3 AL2

Data(UPS->Computer)

Name	Type	Range/Length	Comment
b0 b1 b2 b3 b4 b5 b6 b7 b8 b9 b10 b11 b12 b13 b14 b15 b16 b17 b18 b19 b20 b21 b22 b23 b24	Integer	25	1=Available 0=Not Supported

Description: b0: UBD, b1: SOV, b2: BTV, b3: WDG, b4: EPO, b5: CPU, b6: SER, b7: ASR, b8: SRS, b9: SDC, b10: IDC, b11: STM, b12: MID, b13: AEL, b14: ELS, b15: SST, b16: EVT, b17: PMA, b18: PMS, b19: PFS, b20: PIS, b21:PCS, b22:PMT, b23:PIV, b24:BPA

3.1.4 AL3

Data(UPS->Computer)

Name	Type	Range/Length	Comment
b0 b1 b2 b3 b4 b5 b6 b7 b8 b9 b10 b11 b12 b13 b14 b15 b16 b17 b18 b19 b20 b21b22b23b24b25	Integer	26	1=Available 0=Not Supported

Description: b0: BT1, b1: BT2, b2: BCT, b3: BUZ, b4: SDA, b5: SDR, b6: TST, b7: RON, b8: ROF, b9: RNF, b10: ECO, b11: BTT, b12: RSM, b13: EDB, b14: EBP, b15: SIV, b16: CSR, b17: STD, b18: CRS, b19: SOS, b20: TME, b21: CHS, b22: PIC, b23:PMV, b24:PMC, b25:LOK

3.1.5 MNU

Data: (UPS->Computer)

Name	Type	Range/Length	Comment
Manufacturer	String	0 to 16	

Description: Read the manufacturer name.

3.1.6 MOD

Data: (UPS->Computer)

Name	Type	Range/Length	Comment
Model	String	0 to 16	
Series	Integer	0 to 5	0 = T 1 = H 2 = NT 3 = NH 4 = DPS 5 = DPH

Description:

- ◆ Read the UPS model name.
- ◆ The Series number is used to compatible with 3Phase protocol to display the related UPS information, this field can be ignored by single phase UPS.

3.1.7 RAT

Data: (UPS->Computer)

Name	Type	Range/Length	Comment
Rating Input Voltage	Integer	0 to 999	Volt
Rating Input Frequency	Integer	0 to 999	0.1Hz
Rating Output Voltage	Integer	0 to 999	Volt
Rating Output Frequency	Integer	0 to 999	0.1Hz
Rating VA	Integer	0 to 999999	VA
Rating Output Power	Integer	0 to 999999	Watt
Low Battery Time (not used, reserved)	Integer	0 to 99	Minute, time from low battery to low battery shutdown
Mains Input Low Tx Voltage Point	Integer	0 to 999	Volt
Mains Input High Tx Voltage Point	Integer	0 to 999	Volt

Mains Input Low Tx Voltage Upper Bound	Integer	0 to 999	Volt
Mains Input Low Tx Voltage Lower Bound	Integer	0 to 999	Volt
Mains Input High Tx Voltage Upper Bound	Integer	0 to 999	Volt
Mains Input High Tx Voltage Lower Bound	Integer	0 to 999	Volt
UPS Type	Integer	0 to 5	0: On-Line 1: Off-Line 2: Line-Interactive 3: 3 Phase 4: Split Phase 5: Others 6: HVDC
Rating Battery Voltage	Integer	0 to 999	Volt
Mains Low Tx Freq Point	Integer	0 to 999	0.1Hz
Mains High Tx Freq Point	Integer	0 to 999	0.1Hz
Bypass Rating Freq	Integer	0 to 999	0.1Hz
Bypass Freq Max Tolerance	Integer	5 to 50	0.1Hz
Bypass Freq Set Tolerance	Integer	5 to 50	0.1Hz
Bypass Low Tx Voltage Point/ Bypass Rating Voltage	Integer	0 to 999	Volt
Bypass High Tx Voltage Point	Integer	0 to 999	Volt
Bypass Low Tx Voltage Upper Bound/ Bypass Voltage Max Tolerance	Integer	0 to 999	Volt
Bypass Low Tx Voltage Lower Bound/ Bypass Voltage Set Tolerance	Integer	0 to 999	Volt
Bypass High Tx Voltage Upper Bound	Integer	0 to 999	Volt
Bypass High Tx Voltage Lower Bound	Integer	0 to 999	Volt
Rating Output Current	Integer	0 to 9999	A

Description: Read the nominal values of UPS.

3.1.8 SDT (obsolete)

Data: (UPS->Computer)

Name	Type	Range/Length	Comment
Shutdown Type	Integer	1 to 2	1 = UPS output (standby) 2 = UPS system (complete shutdown)

Description: Read the shutdown type of UPS.

3.1.9 STB

Data: (UPS->Computer)

Name	Type	Range/Length	Comment
Battery Condition	Integer	0 to 2	0 = Good 1 = Weak 2 = Replace
Battery Status	Integer	0 to 2	0 = OK 1 = Low 2 = Depleted
Battery Charge	Integer	0 to 3	0 = (obsolete) 1 = Charging 2 = Resting 3 = Discharging
Seconds on Battery	Integer	0 to 99999	Seconds
Estimated Minutes Remaining	Integer	0 to 9999	Estimated time from backup to low battery shutdown.
Estimated Charge Remaining (not used, reserved)	Integer	0 to 999	Estimated of percent battery charge remaining.
Battery Voltage	Integer	0 to 9999	0.1Volt
Battery Current	Integer	0 to 9999	0.1Amp
UPS Internal Temperature	Integer	0 to 999	Degree Celsius
Battery Level	Integer	0 to 100	%
External Batt-Pack Number	Integer	0 to 10	Number of External Battery Pack
Negative Battery Voltage	Integer	0 to 9999	-0.1Volt
Negative Battery Current	Integer	0 to 9999	0.1Amp
not used, reserved			
Negative Battery Level	Integer	0 to 999	%
Positive Charging Current	Integer	0 to 9999	0.1Amp
Negative Charging Current	Integer	0 to 9999	0.1Amp
Battery Charge Mode	Integer	0 to 2	0 = None 1 = Boost charge 2 = Float charge
Battery Low Limit	Integer	0 to 100	%, if this field is available then the BLA command is supported

3.1.10 STI

Data: (UPS->Computer)

Name	Type	Range/Length	Comment
Input Num Lines(Phases)	Integer	0 to 9	Number of input lines
Input Frequency1	Integer	0 to 999	0.1Hz
Input Voltage1	Integer	0 to 9999	0.1Volt
Input Current1	Integer	0 to 9999	0.1Amp
Input Power1	Integer	0 to 99999	Watt
Input Frequency2	Integer	0 to 999	0.1Hz
Input Voltage2	Integer	0 to 9999	0.1Volt
Input Current2	Integer	0 to 9999	0.1Amp
Input Power2	Integer	0 to 99999	Watt
Input Frequency3	Integer	0 to 999	0.1Hz
Input Voltage3	Integer	0 to 9999	0.1Volt
Input Current3	Integer	0 to 9999	0.1Amp

Input Power3	Integer	0 to 99999	Watt
Input Voltage12	Integer	0 to 9999	0.1Volt
Input Voltage23	Integer	0 to 9999	0.1Volt
Input Voltage31	Integer	0 to 9999	0.1Volt

3.1.11 STO

Data: (UPS->Computer)

Name	Type	Range/Length	Comment
Output Source	Integer	0 to 7	0 = Normal 1 = Battery 2 = Bypass (3phase Reserve Power Path) 3 = Reducing 4 = Boosting 5 = Manual Bypass 6 = Other 7 = No output 8 = On ECO
Output Frequency	Integer	0 to 999	0.1Hz
Output Num Lines(Phase)	Integer	0 to 9	Number of output lines
Output Voltage1	Integer	0 to 9999	0.1Volt
Output Current1	Integer	0 to 99999	0.1Amp
Output Power1	Integer	0 to 999999	Watt
Output Load1	Integer	0 to 999	Percent
Output Voltage2	Integer	0 to 9999	0.1Volt
Output Current2	Integer	0 to 99999	0.1Amp
Output Power2	Integer	0 to 999999	Watt
Output Load2	Integer	0 to 999	Percent
Output Voltage3	Integer	0 to 9999	0.1Volt
Output Current3	Integer	0 to 99999	0.1Amp
Output Power3	Integer	0 to 999999	Watt
Output Load3	Integer	0 to 999	Percent
Output Voltage12	Integer	0 to 9999	0.1Volt
Output Voltage23	Integer	0 to 9999	0.1Volt
Output Voltage31	Integer	0 to 9999	0.1Volt
Total Output Power KW	Integer	0 to 99999	0.1KW
Total Output Power KVA	Integer	0 to 99999	0.1KVA
Total Output Power Factor	Integer	0 to 999	KW/KVA %

Description: The present source of output power.

On-Line UPS status may be 0, 1, 2

Off-Line UPS status may be 1, 2, 3, 4

3 Phase UPS status may be 0, 1, 2, 5

3.1.12 STP

Data: (UPS->Computer)

Name	Type	Range/Length	Comment
------	------	--------------	---------

Bypass Frequency	Integer	0 to 999	0.1Hz
Bypass Num Lines(Phase)	Integer	0 to 9	Number of bypass lines
Bypass Voltage1	Integer	0 to 9999	0.1Volt
Bypass Current1	Integer	0 to 99999	0.1Amp
Bypass Power1	Integer	0 to 999999	Watt
Bypass Voltage2	Integer	0 to 9999	0.1Volt
Bypass Current2	Integer	0 to 99999	0.1Amp
Bypass Power2	Integer	0 to 999999	Watt
Bypass Voltage3	Integer	0 to 9999	0.1Volt
Bypass Current3	Integer	0 to 99999	0.1Amp
Bypass Power3	Integer	0 to 999999	Watt
Bypass Voltage12	Integer	0 to 9999	0.1Volt
Bypass Voltage23	Integer	0 to 9999	0.1Volt
Bypass Voltage31	Integer	0 to 9999	0.1Volt
Bypass STS Temperature	Integer	0 to 999	Degree Celsius

3.1.13 STA

Data: (UPS->Computer)

Name	Type	Range/Length	Comment
Alarm Over Temperature	Integer	0 or 1	0 = OK 1 = Over Temperature
Alarm Input Out Of Range	Integer	0 or 1	0 = OK 1 = Input Bad
Alarm Output Bad (obsolete, reserved)	Integer	0 or 1	0 = OK 1 = Output Bad
Alarm Overload	Integer	0 or 1	0 = OK 1 = Overload
Alarm Bypass Out Of Range	Integer	0 or 1	0 = OK 1 = Bypass Bad
Alarm Output Off	Integer	0 or 1	0 = Output On 1 = Output Off
Alarm UPS Shutdown	Integer	0 or 1	0 = OK 1 = Shutdown
Alarm Charger Fail	Integer	0 or 1	0 = OK 1 = Charger Failed
Alarm Standby	Integer	0 or 1	0 = Others 1 = Standby
Alarm Fan Fail	Integer	0 or 1	0 = OK 1 = Fan Fault
Alarm Fuse Fail	Integer	0 or 1	0 = OK 1 = Fuse Fault
Alarm Other Warning	Integer	0 or 1	0 = OK 1 = General Fault
Alarm Awaiting Power	Integer	0 or 1	0 = OK 1 = Awaiting Power
Alarm Shutdown Pending	Integer	0 or 1	0 = OK 1 = Shutdown Pending

Alarm Shutdown Imminent	Integer	0 or 1	0 = OK 1 = Shutdown Imminent
Buzzer Status	Integer	0 or 1	0 = UPS Buzzer Silence 1 = UPS Buzzer is Alarming
Economic Mode	Integer	0 or 1	0 = No 1 = Yes
Alarm Inverter Fail	Integer	0 or 1	0 = No 1 = Yes
Emergency Power Off	Integer	0 or 1	0 = Off 1 = On
Buzzer State	Integer	0 or 1	0 = UPS Buzzer Disable 1 = UPS Buzzer Enable
Battery Ground Fault	Integer	0 or 1	0: normal 1: ground fault
Alarm Output Voltage Over Limit	Integer	0 or 1	0: normal 1: Alarm
Alarm Output Voltage Under Limit	Integer	0 or 1	0: normal 1: Alarm
Alarm Power Module	Integer	0 or 1	0: normal 1: Alarm
Alarm Output Breaker Open	Integer	0 or 1	0: Close 1: Open
Alarm Phase Asynchronous	Integer	0 or 1	0: Phase Synchronous 1: Phase Asynchronous
Alarm Rectifier Abnormal	Integer	0 or 1	0: Normal 1: Alarm
Bypass Breaker Open	Integer	0 or 1	0: Close 1: Open
Main Input Breaker Open	Integer	0 or 1	0: Close 1: Open

3.1.14 TSR

Data:(UPS->Computer)

Name	Type	Range/Length	Comment
Test Result	Integer	0 to 6	0 = No test performed 1 = Test passed 2 = Test in progress 3 = General test failed (Obsolete) 4 = Battery test failed 5 = Deep battery test failed (Obsolete) 6 = Test Aborted

3.1.15 VER

Data: (UPS->Computer)

Name	Type	Range/Length	Comment
UPS Firmware Version	String	0 to 16	

3.1.16 TXV

Data: (UPS->Computer)

Name	Type	Range/Length	Comment
Low Transfer Voltage	Integer	0 to 999	Volt
High Transfer Voltage	Integer	0 to 999	Volt

3.1.17 VSN

Data: (UPS->Computer)

Name	Type	Range/Length	Comment
Voltage Sensitivity	Integer	0 to 2	0 = Normal 1 = Reduced 2 = Low

3.1.18 LET

Data: (UPS->Computer)

Name	Type	Range/Length	Comment
Number of Output Relay	Integer	0 to 99	0 = Not available >0 Available

3.1.19 SOL

Data: (Computer->UPS)

Name	Type	Range/Length	Comment
Index of Output Relay	Integer	1 to 99	

Data: (UPS->Computer)

Name	Type	Range/Length	Comment
Normal or Shutdown	Integer	0 or 1	0 = Normal 1 = Shutdown

3.1.20 BRD

Data: (UPS->Computer)

Name	Type	Range/Length	Comment
Last Battery Replacement Date	String	8	YYYYMMDD
Next Battery Replacement Date	String	8	YYYYMMDD

3.1.21 ATT

Data: (UPS->Computer)

Name	Type	Range/Length	Comment
UPS Periodic Auto-Test	Integer	1 to 5	1 = Disable 2 = Daily 3 = Weekly 4 = BiWeekly 5 = Monthly

3.1.22 ARB

Data: (UPS->Computer)

Name	Type	Range/Length	Comment
------	------	--------------	---------

Backup mode Auto-Restart	Integer	1 to 2	1 = Enable(default) 2 = Disable
--------------------------	---------	--------	------------------------------------

Description: In backup mode, the UPS may shutdown normally by SDA command, dry-contact remote shutdown signal or low battery shutdown. This command is used to determine the unit should restart or not next time when the power restores.

3.1.23 TXF

Data: (UPS->Computer)

Name	Type	Range/Length	Comment
Bypass Frequency Tolerance	Integer	5 to 50	0.1Hz

3.1.24 UBD

Data: (UPS->Computer)

Name	Type	Range/Length	Comment
UPS Boot Delay	Integer	0 to 999	Seconds

Description: Delay the UPS startup after power restores, it is related to ARM command. The power quality may not stable when power restores, this feature let the UPS wait a period of time to startup the system.

3.1.25 BTV

Data: (UPS->Computer)

Name	Type	Range/Length	Comment
Test Time	Integer	1 to 999	Minutes
Test Voltage	Integer	0 to 999	Voltage

Description: This command is the same as 3Phase protocol. If battery voltage is lower than the "Test Voltage" which is set by users then UPS reports test fail. This kind of battery test is triggered by TST(2) command.

3.1.26 EPO

Data: (UPS-> Computer)

Name	Type	Range/Length	Comment
Emergency Power Off	Integer	1 to 2	1=Enable(default) 2=Disable

Description: Enables or Disables EPO functionality via communication port

3.1.27 CPU

Data: (UPS-> Computer)

Name	Type	Range/Length	Comment
Communication Protocol of the Unit	String	4	New On-Line: "4001" means 0x4001 Split Phase: "4002" means 0x4002 New H-series: "5001" New H-series without checksum: "4100"

Description: Identify the communication protocol.

3.1.28 SER

Data: (UPS-> Computer)

Name	Type	Range/Length	Comment
Serial Number	String	20	Serial Number

Description: Report serial number of the unit.

3.1.29 DWR

Data: (UPS-> Computer)

Name	Type	Range/Length	Comment
Major Code	Integer	0 to 255	
Sub Code	Integer	0 to 255	0 = Not Support 1~255 = Sub-Code
Major Code	Integer	0 to 255	
Sub-Code	Integer	0 to 255	0 = Not Support 1~255 = Sub-Code
...			

Description: Provide the shutdown reasons from UPS.

3.1.30 AEL

Data: (UPS-> Computer)

Name	Type	Range/Length	Comment
UPS Event Log Entry	Integer	0 to 500	
Event log report format	Integer	0 to 2	0: NT 9 byte format 1: NH 8 byte format 2: Oline 6 byte format
Event Reporting method	Integer	0 to 1	0: ELS 1: EVT

Description: Return the UPS Event Log type.

3.1.31 EVT

Data: (Computer->UPS)

Name	Type	Range/Length	Comment
Start Index of the events	Integer	1 to 500	
Length of events	Integer	1 to 500	

Description: For example, the host needs 20 events of data that starts from index 300, then the "start index of the events" is 300 and the length of events is 20. For the NH 8 byte event format, the ups will need to send out 20*8 bytes of event data to the host.

Data: (UPS->Computer)

Name	Type	Range/Length	Comment
Event data contents	Binary Data		

3.1.32 ELS

Data: (Computer->UPS)

Name	Type	Range/Length	Comment
Segment Index	Integer	1 to 23	

Description: PC will receive 4500 bytes, we cut this block into 23 segments, each segments contains 200 bytes except the last segment.

Data: (UPS->Computer)

Name	Type	Range/Length	Comment
Segment Index	Integer	1 to 23	
Segment Content	Binary Data	200 bytes	

3.1.33 TME

Data: (UPS-> Computer)

Name	Type	Range/Length	Comment
Format	Integer	1 to 2	1 = Life Time in Second 2 = Date/Time
Time String	String	14 bytes	Life Time in Seconds: Accumulated life time in seconds Date/Time: YYYYMMDDhhmmss

3.1.34 CHS

Data: (UPS-> Computer)

Name	Type	Range/Length	Comment
Current Step	Integer	1 to 10	Indicate the current charging step which is listed in the following
Step1	String	5 bytes	AUTO = The charger is controlling the charger automatically 1.0A, 2.0A, 3.0A, ... = The charger steps
Step2	String	5 bytes	
Step3	String	5 bytes	
...	String	5 bytes	

3.1.35 LOK

Data: (UPS-> Computer)

Name	Type	Range/Length	Comment
Startup Status	Integer	0 to 4	0: Unknown(SET LOK is not performed or the format of SET LOK is not correct) 1: Lock Success 2: Lock Fail 3: Unlock Success 4: Unlock Fail

3.2 Regular Format Set Commands

Command	Description
General Commands	
BUZ	Switch UPS Buzzer
SDA	Shutdown Action
SDR	Restart Action
SDT	Shutdown Type
TST	Test Type
TXV	Transfer Voltage

VSN	Voltage Sensitivity
RON	Outlet Relay On
ROF	Outlet Relay Off
RNF	Outlet Relay On and Off
BRD	Battery Replacement Date
ECO	Economic Mode enable/disable
ATT	Auto Test
BTT	Buzzer Test
ARB	AC Fail & Restore Auto-Reboot enable/disable
UBD	UPS Boot Delay
TXF	Transfer Bypass Frequency
EDB	Enable/Disable Buzzer
BTV	Battery Test Time & Voltage
EPO	Emergency Power Off
EBP	Number of External Battery Pack
CLR	Clear To The Specified Object
CHS	Charger Steps
LOK	Set lock key to lock/unlock machine startup
BLA	Set Battery Low Limit Value
EMS	Inform the temperature and humidity to the UPS.
3Phase Commands	
SIV	Set Inverter On/Off
CSR	Clear SRAM
STD	Set Date/Time to UPS
SDC	Dry Contact Configuration
CRS	Cancel Shutdown Restart
SOS	Set Output On/Off for 3Phase
BT1	Set the Bypass Tx Voltage by Method1
BT2	Set the Bypass Tx Voltage by Method2
IDC	Dry Contact Input Configuration

3.2.1 BUZ

Data: (Computer->UPS)

Name	Type	Range/Length	Comment
UPS Buzzer	Integer	1 or 2	1 = Buzzer Alarm 2 = Buzzer Silence

Description:

- ◆ Buzzer Alarm: UPS system alarms normally.
- ◆ Buzzer Silence: UPS will keep silence but will alarm again when next power event occurs i.e., silence current alarm until next alarm condition.

3.2.2 SDA

Data: (Computer->UPS)

Name	Type	Range/Length	Comment
Shutdown Action	Integer	0 or 1 to 9999	0 = Abort >0 = Seconds

Description: Performs shutdown action after the seconds.

3.2.3 SDR

Data: (Computer->UPS)

Name	Type	Range/Length	Comment
Restart Action	Integer	0 to 65535	0~65534: Minutes to restart 65535: Cancel restart

Description: Perform restart action after indicated number of minutes. 65534 minutes ==: 45 days.

3.2.4 SDT (obsolete)

Data:(Computer->UPS)

Name	Type	Range/Length	Comment
Shutdown Type	Integer	1 or 2	1 = UPS output (all outlet relay) 2 = UPS system

Description: Defines action to be taken at UPS shutdown.

3.2.5 TST

Data:(Computer->UPS)

Name	Type	Range/Length	Comment
Test	Integer	0 to 4	0 = Abort test 1 = General test (Obsolete) 2 = BTV test 3 = Test for 10 seconds 4 = Test until battery low

Description: Application support only 0, 2, 3, 4. The value 2 is used to begin the test set by BTV command.

3.2.6 TXV

Data: (Computer->UPS)

Name	Type	Range/Length	Comment
Mains Low Transfer Voltage	Integer	0 to 999	Volt
Mains High Transfer Voltage	Integer	0 to 999	Volt

Description: Sets high and low transfer voltages.

3.2.7 VSN

Data: (Computer->UPS)

Name	Type	Range/Length	Comment
Voltage Sensitivity	Integer	0 to 2	0 = Normal 1 = Reduced 2 = Low

Description: Sets UPS voltage sensitivity.

3.2.8 RON

Data: (Computer->UPS)

Name	Type	Range/Length	Comment
Outlet Relay Index	Integer	>0	

Delay Time	Integer	0 to 9999	0: Cancel >0: Seconds
------------	---------	-----------	--------------------------

Description: Perform relay on after the seconds.

3.2.9 ROF

Data: (Computer->UPS)

Name	Type	Range/Length	Comment
Outlet Relay Index	Integer	>0	
Delay Time	Integer	0 to 9999	0: Cancel >0: Seconds

Description: Perform relay off after the seconds.

3.2.10 RNF

Data: (Computer->UPS)

Name	Type	Range/Length	Comment
Outlet Relay Number	Integer	>0	
Turn Off Delay Time	Integer	1 to 9999	Seconds
Turn On Delay Time	Integer	1 to 65535	Minute

Description: Perform relay off and on.

3.2.11 BRD

Data: (Computer->UPS)

Name	Type	Range/Length	Comment
Last Battery Replacement Date	String	8	YYYYMMDD
Next Battery Replacement Date	String	8	YYYYMMDD

3.2.12 ECO

Data: (Computer->UPS)

Name	Type	Range/Length	Comment
Switch Economic Mode	Integer	1 to 2	1 = Goto ECO mode 2 = Back from ECO mode

3.2.13 ATT

Data: (Computer->UPS)

Name	Type	Range/Length	Comment
Set Periodic Auto-Test	Integer	1 to 5	1 = Disable 2 = Daily 3 = Weekly 4 = BiWeekly 5 = Monthly

3.2.14 BTT

Data: (Computer->UPS)

Name	Type	Range/Length	Comment
Buzzer Test	Integer	1 to 99	Seconds

3.2.15 ARB

Data: (Computer->UPS)

Name	Type	Range/Length	Comment
AC Fail & Restore Auto-Reboot	Integer	1 to 2	1 = Enable(default) 2 = Disable

Description: In backup mode, the UPS may shutdown normally by SDA command, dry-contact remote shutdown signal or low battery shutdown. This command is used to determine the unit should restart or not next time when the power restores.

3.2.16 UBD

Data: (Computer->UPS)

Name	Type	Range/Length	Comment
UPS Boot Delay	Integer	0 to 999	Seconds

Description: Delay the UPS startup after power restores, it is related to ARB command. The power quality may not stable when power restores, this feature let the UPS wait a period of time to startup the system.

3.2.17 TXF

Data: (Computer->UPS)

Name	Type	Range/Length	Comment
Bypass Tx Freq Tolerance	Integer	5 to 50	0.1 Hz

Description: Sets tolerance of bypass transfer frequency.

3.2.18 EDB

Data: (Computer->UPS)

Name	Type	Range/Length	Comment
Enable/Disable Buzzer	Integer	1 to 2	1 = Enable(Default) 2 = Disable

Description: Enable/Disable UPS buzzer.

3.2.19 BTV

Data: (Computer->UPS)

Name	Type	Range/Length	Comment
Test Time	Integer	1 to 60	Minutes
Test Voltage	Integer	0 to 999	Voltage

Description: This command is the same as 3Phase UPS's. If battery voltage is lower than the "Test Voltage" which is set by the user then UPS reports test fail. This kind of battery test is triggered by TST(2) command.

3.2.20 EPO

Data: (Computer->UPS)

Name	Type	Range/Length	Comment
Emergency Power Off	Integer	1 to 2	1 = Enable(default) 2 = Disable

Description: Enables or Disables EPO functionality via communication port. Please note that this command is not used to trigger EPO action.

3.2.21 EBP

Data: (Computer->UPS)

Name	Type	Range/Length	Comment
External Battery Pack Number	Integer	0 to 100	

Description: Assign the number of external battery pack.

3.2.22 CLR

Data: (Computer->UPS)

Name	Type	Range/Length	Comment
Object	Integer	1 to 2	1 = Event Log 2 = Life Time

Description: Clear the specified object.

3.2.23 CHS

Data: (Computer->UPS)

Name	Type	Range/Length	Comment
Charger Step	Integer	1 to 10	Select the charger step which is listed by polling CHS

Description: Assign the charger step.

3.2.24 LOK

Data: (Computer->UPS)

Name	Type	Range/Length	Comment
Lock Key1	Integer	1~65534	Set lock key1. 0/65535 is invalid.
Lock Key2	Integer	1~65534	Set lock key2. 0/65535 is invalid.
Lock/Unlock	Integer	1/0	Lock(1)/Unlock(0)

Description: Lock/unlock machine startup function for UPS shipment management. If the production line set the password and lock keys in the EEPROM, the user needs to use the command to unlock the UPS, otherwise the UPS can't power on by on key. Two words are used for the lock keys. 0 and 65535 are invalid for the lock keys

3.2.25 BLA

Data: (Computer->UPS)

Name	Type	Range/Length	Comment
Battery Low Limit	Integer	0 to 100	

Description: Set the battery low limit value to the UPS if the Battery Low Limit field is available in the STB command. The UPS should keep this value in the EEPROM and compare with it to indicate the batter low alarm.

3.2.26 EMS

Data: (Computer->UPS)

Name	Type	Range/Length	Comment
Temperature	Integer	-400 to 1000	0.1 degree C
Humidity	Integer	0 to 100	1 %
DI1	Integer	0 or 1	0: Normal, 1: Alarm

DI2	Integer	0 or 1	0: Normal, 1: Alarm
DI3	Integer	0 or 1	0: Normal, 1: Alarm
DI4	Integer	0 or 1	0: Normal, 1: Alarm

Description: Report the EMS1000 environment parameters to the connected UPS.

3.3 3Phase Polling Commands

Command	Description
ASR	Check SRAM Exist
SRS	Get the SRAM by Segment Number
SDC	Dry Contact Output Status for 3Phase
IDC	Dry Contact Input Status
STM	Temp Status (NT)
MID	Parallel Master ID (NT)
SST	Status for 3Phase UPS
PMA	Power Module Attribute
PMS	Power Module Status
PFS	Power Module PFC Status
PIS	Power Module Inverter Status
PCS	Power Module Charger Status
PMT	Power Module Temperature
PIV	Power Module Inverter Voltage
PIC	Power Module Inverter Current
PMV	Power Module main input Voltage
PMC	Power Module main input Current
BPA	Power Module Bypass
BT1	Get the Bypass Tx Voltage by method1
BT2	Get the Bypass Tx Voltage by method2
BCT	Battery Cabinet Temperature

3.3.1 ASR for 3Phase

Data: (UPS-> Computer)

Name	Type	Range/Length	Comment
SRAM Exist	Integer	0 or 1	0 = Not exist 1 = Existed

3.3.2 SRS for 3Phase

Data: (Computer->UPS)

Name	Type	Range/Length	Comment
Segment Index	Integer	1 to 20	

Description: PC will receive 4000 bytes, we cut this block into 20 segments, each segment contains 200 bytes.

Data: (UPS->Computer)

Name	Type	Range/Length	Comment
Segment Index	Integer	1 to 20	

Segment Content	Binary Data	200 bytes	
-----------------	-------------	-----------	--

Description:

The items include:

Input => (0) RS Volt, (1) ST Volt, (2) TR Volt, (3) R Volt, (4) S Volt, (5) T Volt,

(6) R Current, (7) S Current, (8) T Current, (9) Freq.

Output => (10) RS Volt, (11) ST Volt, (12) TR Volt, (13) R Volt, (14) S Volt, (15) T Volt, (16) R
Current, (17) S Current, (18) T Current, (19) Freq.

Battery => (20) Current, (21) Voltage

(22) UPS Status

3.3.3 SDC for 3Phase

Data: (UPS-> Computer)

Name	Type	Range/Length	Comment
Dry Contact Output Status	Binary Data	12 bytes	DryStatusW1 ~ DryStatusW6

Description:

The byte order is DryStatusW1(Lo), DryStatusW1(Hi), ..., DryStatusW6(Lo), DryStatusW6(Hi)

High Byte

B7: 0=Normal Open, 1=Normal Close

B5 ... B0: 0=None, 1=Dry Contact1, 2=Dry Contact2, ..., 6=Dry Contact6

Low Byte

B7: 0=Inactive, 1=Active

B6 ... B0: 0=None, 1=Event1, ... 20=Event20

3.3.4 STM for 3Phase

Data: (UPS-> Computer)

Name	Type	Range/Length	Comment
TempStatus	Binary Data	20 bytes	

Description:

- Items order is Temp1-R(Lo), Temp1-R(Hi), Temp2-S(Lo), Temp2-S(Hi), Temp3-T(Lo), Temp3-T(Hi), Temp4-PUPS(Lo), Temp4-PUPS(Hi), HT-Temp(Lo), HT-Temp(Hi), AT-Temp(Lo), AT-Temp(Hi), BT-Temp(Lo), BT-Temp(Hi), CFW1(Lo), CFW1(Hi), CFW2(Lo) Reserve, CFW2(Hi) Reserve, CBW1(Lo) Reserve, CBW1(Hi) Reserve
- Temp1-R(Lo) : R Phase Inverter Temperature
- Temp1-R(Hi): B0: Temperature Warning(>=75C)
B1: High Temperature Shutdown(>=85C)
B2: Inverter Voltage too Low
B3: Inverter Voltage too High
B4: Overload Warning
B5: Overload Shutdown

- B6: Inverter Fuse Fail Shutdown
- B7: Inv. PCB communication abnormal
- Temp2-S(Lo): S Phase Inverter Temperature
- Temp2-S(Hi): B0: Temperature Warning($\geq 75\text{C}$)
 - B1: High Temperature Shutdown($\geq 85\text{C}$)
 - B2: Inverter Voltage too Low
 - B3: Inverter Voltage too High
 - B4: Overload Warning
 - B5: Overload Shutdown
 - B6: Inverter Fail Shutdown
 - B7: Parallel Communication Abnormal
- Temp3-T(Lo): T Phase Inverter Temperature
- Temp3-T(Hi): B0: Temperature Warning($\geq 75\text{C}$)
 - B1: High Temperature Shutdown($\geq 85\text{C}$)
 - B2: Inverter Voltage too Low
 - B3: Inverter Voltage too High
 - B4: Overload Warning
 - B5: Overload Shutdown
 - B6: Inverter Freq. Abnormal Shutdown
 - B7: Parallel Communication Fail
- Temp4-(Lo): B3 .. B0: The Summary of UPS Run at Inverter Test Mode
B7 .. B4: The Summary of UPS Run at Inverter Mode
- Temp4-(Hi): B0: Power Fail
 - B1: EPO Happen
 - B2: MB_ON(To Bypass)
 - B3: Battery Low Warning
 - B4: Battery Low Shutdown
 - B5: Master UPS(Output Sync)
 - B6: Inverter DC Bus Abnormal Shutdown
 - B7: Short Circuit Happen Shutdown
- HT-Temp(Lo): Heatsink Temperature
- HT-Temp(Hi): B0: Bypass Voltage Over
 - B1: Bypass Voltage Under
 - B2: Bypass Freq. Abnormal
 - B3: Bypass Phase Abnormal
 - B4: Rectifier Voltage Over

- B5: Rectifier Voltage Under
- B6: Rectifier Freq. Abnormal
- B7: Rectifier Phase Abnormal
- AT-Temp(Lo): Ambient Temperature
- AT-Temp(Hi):
 - B0: Bypass Voltage Over
 - B1: Bypass Voltage Under
 - B2: SSW at Bypass Side
 - B3: SSW at Inverter Side
 - B4: Rectifier Voltage Over
 - B5: Rectifier Voltage Under
 - B6: Rectifier Input Over Current
 - B7: Rectifier Input Current Unbalance
- BT-Temp(Lo): Battery Temperature
- BT-Temp(Hi):
 - B0: Bypass Voltage Over
 - B1: Bypass Voltage Under
 - B2: Low Battery Shutdown
 - B3: Low Battery Warning
 - B4: Rectifier Voltage Over
 - B5: Rectifier Voltage Under
 - B6: Rectifier Fail
 - B7: DC Bus Over Voltage
- CFW1(Lo):
 - B0: TR1 Over Temperature(O/P TR Over Heat Shutdown)
 - B1: TR2 Input Choke Over Heat(I/P TR Over Heat Shutdown)
 - B2: Rectifier Over Temperature Warning($\geq 75\text{C}$)
 - B3: Rectifier Over Temperature Shutdown($\geq 85\text{C}$)
 - B4: Static Switch Over Temperature Warning($\geq 75\text{C}$)
 - B5: Static Switch Over Temperature Shutdown($\geq 85\text{C}$)
 - B6: Static Switch Overload
 - B7: Static Switch Fail
- CFW1(Hi):
 - B0: Converter Board Power Abnormal
 - B1: EPO Happen
 - B2: Manual Bypass On
 - B3: Converter Board Communication Error
 - B4: Battery Cabinet Over Temperature Warning($\geq 75\text{C}$)
 - B5: Battery Ground Fault
 - B6: Battery Test in Progress

B7: Battery Test Fail

- CBW1(Hi): B5: Ambiance Over Temperature

B7: Auxiliary Power Fail

3.3.5 MID for 3Phase

Data: (UPS-> Computer)

Name	Type	Range/Length	Comment
Parallel Master ID	Integer	0 to 99	

Description: Return the parallel master ID.

3.3.6 SST for 3Phase

Data: (UPS->Computer)

Name	Type	Range/Length	Comment
Alarm Rectifier Main Fail	Integer	0 or 1	0 = De-Active 1 = Active
Alarm Rectifier Hi DC Stop	Integer	0 or 1	0 = De-Active 1 = Active
Alarm Over Temperature or Fuse Failure	Integer	0 or 1	0 = De-Active 1 = Active
Alarm Battery Low	Integer	0 or 1	0 = De-Active 1 = Active
Alarm Battery Low Stop	Integer	0 or 1	0 = De-Active 1 = Active
Alarm Battery Ground Fault	Integer	0 or 1	0 = De-Active 1 = Active
Inverter ON	Integer	0 or 1	0 = De-Active 1 = Active
Alarm Inverter Overload	Integer	0 or 1	0 = De-Active 1 = Active
Alarm Inverter Abnormal	Integer	0 or 1	0 = De-Active 1 = Active
Alarm Load On Reserve	Integer	0 or 1	0 = De-Active 1 = Active
Alarm Reserve Mains Fail	Integer	0 or 1	0 = De-Active 1 = Active
Alarm Reserve Frequency Abnormal	Integer	0 or 1	0 = De-Active 1 = Active
Alarm Test In Progress	Integer	0 or 1	0 = De-Active 1 = Active
Alarm Test Error	Integer	0 or 1	0 = De-Active 1 = Active
UPS in Sleep Mode	Integer	0 or 1	0 = De-Active 1 = Active
Reserved	Integer	0 or 1	0 = De-Active 1 = Active

Description:

3.3.7 PMA

Data: (UPS->Computer)

Name	Type	Range/Length	Comment
Power Module ID	Integer	1 to 99	
Power Module Attribute	Integer	0 to 255	
Power Module ID	Integer	1 to 99	
Power Module Attribute	Integer	0 to 255	
Power Module ID...	Integer	1 to 99	
...			

Description :

Power Module ID: The power module ID that exists in the system

Power Module Attribute: which is used to identify the attribute of the power module.

B0: PFC

B1: Rectifier

B2: Charger

B3: Inverter

B4: Bypass

B5: TBD

B6: TBD

B7: TBD

For example, if the power module includes PFC, DCDC, charger, and inverter power circuitry, then bit B0, B2, and B3 is '1', and the others are '0'.

3.3.8 PMS

Data: (UPS->Computer)

Name	Type	Range/Length	Comment
Power Module ID	Integer	1 to 99	
Power Module General Status	Integer	0 to 255	
Power Module ID	Integer	1 to 99	
...			

Description :

Power Module ID: The power module ID that exists in the system

Power Module General Status:

B0: The power module exist or the power module is powered

B1:

B2:

B3:

B4:

B5:

B6: Repair (NH+: The front screw is open)

B7: Fault shutdown

3.3.9 PFS

Data: (UPS->Computer)

Name	Type	Range/Length	Comment
Power Module ID	Integer	1 to 99	
PFC Status - 0	Integer	0 to 255	B0~B7
PFC Status - 1	Integer	0 to 255	B8~B15
Power Module ID...	Integer	1 to 99	
...			

Description:

Power Module ID: The power module ID that exists in the system

PFC Status:

B0: PFC fuse open fault

B1: PFC over temperature warning

B2: PFC over temperature shutdown

B3: DC bus over voltage warning

B4: DC bus over voltage shutdown

B5: DC bus under voltage warning

B6: DC bus under voltage shutdown

B7: PFC circuit general fault

B8: Fan failure

B9: Output Current Limit

B10: PFC Off

B11: Battery fuse open warning

B12: Inner communication failure

B13: TBD

B14: TBD

B15: Not calibrated (used to indicate whether the power module has been calibrated)

3.3.10 PIS

Data: (UPS->Computer)

Name	Type	Range/Length	Comment
Power Module ID	Integer	1 to 99	
Inverter Status - 0	Integer	0 to 255	B0~B7
Inverter Status - 1	Integer	0 to 255	B8~B15
Inverter Status - 2	Integer	0 to 255	B16~B23
Power Module ID...	Integer	1 to 99	
...			

Description :

Power Module ID: The power module ID that exists in the system

Inverter Status:

- B0: Inverter fuse open
- B1: Inverter over temperature warning
- B2: Inverter over temperature shutdown
- B3: Fan failure
- B4:
- B5: Inverter short circuit
- B6: Inverter STS failure
- B7: Inverter voltage abnormal
- B8: Inverter circuit general fault shutdown
- B9: DC bus over voltage shutdown
- B10: Inverter overload
- B11:
- B12: Inner communication loss (includes the comm. to system or other modules)
- B13: EPO shutdown
- B14: Inverter parallel communication loss
- B15: Inverter parallel failure (which may due to any of ID, or rating setting conflict, etc...)
- B16: TBD
- B17: TBD
- B18: TBD
- B19: TBD
- B20: TBD
- B21: Inverter Off
- B22: STS on/off. 1:on,0:off.
- B23: Not calibrated (used to indicate whether the power module has been calibrated)

3.3.11 PCS

Data: (UPS->Computer)

Name	Type	Range/Length	Comment
Power Module ID	Integer	1 to 99	
Charger Status	Integer	0 to 255	B0~B7
Power Module ID...	Integer	1 to 99	
...			

Description :

Power Module ID: The power module ID that exists in the system

PFC Status:

B0: Charger circuit general fault

B1:

B2:

B3:

B4:

B5:

B6:

B7:

3.3.12 PMT

Data: (UPS->Computer)

Name	Type	Range/Length	Comment
Power Module ID	Integer	1 to 99	
Temperature - PFC	Integer	0 to 999	Degree Celsius
Temperature - TBD	Integer	0 to 999	Degree Celsius
Temperature – Inverter	Integer	0 to 999	Degree Celsius
Temperature – Inverter R	Integer	0 to 999	Degree Celsius
Temperature – Inverter S	Integer	0 to 999	Degree Celsius
Temperature – Inverter T	Integer	0 to 999	Degree Celsius
Power Module ID...	Integer	1 to 99	
...			

3.3.13 PIV

Data: (UPS->Computer)

Name	Type	Range/Length	Comment
Power Module ID	Integer	1 to 99	
Inverter volts – R	Integer	0 to 9999	0.1V
Inverter volts – S	Integer	0 to 9999	0.1V
Inverter volts – T	Integer	0 to 9999	0.1V
Power Module ID...	Integer	1 to 99	
...			

3.3.14 BPA

Data: (UPS->Computer)

Name	Type	Range/Length	Comment
Alarm bypass voltage/freq bad	Integer	0 or 1	
Alarm bypass phase sequence bad	Integer	0 or 1	
Alarm bypass STS overload	Integer	0 or 1	
Alarm bypass STS over temperature	Integer	0 or 1	
Alarm bypass STS Fault	Integer	0 or 1	

3.3.15 BT1

Data: (UPS->Computer)

Name	Type	Range/Length	Comment
Bypass Low Transfer Voltage	Integer	0 to 999	Volt

Bypass High Transfer Voltage	Integer	0 to 999	Volt
------------------------------	---------	----------	------

3.3.16 BT2

Data: (UPS->Computer)

Name	Type	Range/Length	Comment
Bypass Voltage Tolerance	Integer	0 to 999	Volt

3.3.17 BCT

Data: (UPS->Computer)

Name	Type	Range/Length	Comment
Battery cabinet #1 temperature	Integer	0 to 999	Degree Celsius
Battery cabinet #2 temperature	Integer	0 to 999	Degree Celsius
Battery cabinet #3 temperature	Integer	0 to 999	Degree Celsius
Battery cabinet #4 temperature	Integer	0 to 999	Degree Celsius
Battery cabinet breaker	Integer	0 to 1	1: close, 0:open

3.3.18 IDC for 3Phase

Data: (UPS-> Computer)

Name	Type	Range/Length	Comment
Dry Contact Input Status	Binary Data	4bytes	DryContact_in_1 ~ DryContact_in_2

Description:

The byte order is DryContact_in_1(Lo), DryContact_in_1(Hi), DryContact_in_2(Lo), DryContact_in_2(Hi)

High Byte

B7: 0=Normal Open, 1=Normal Close

B5 ... B0: 0=None, 1=Dry Contact_in_1, 2=Dry Contact_in_2

Low Byte

B7: 0=Inactive, 1=Active

B6 ... B0: 0=None, 1=Event1, ... 20=Event20

3.3.19 PIC

Data: (UPS->Computer)

Name	Type	Range/Length	Comment
Power Module ID	Integer	1 to 99	
Inverter volts – R	Integer	0 to 9999	0.1A
Inverter volts – S	Integer	0 to 9999	0.1A
Inverter volts – T	Integer	0 to 9999	0.1A
Power Module ID...	Integer	1 to 99	

3.3.20 PMV

Data: (UPS->Computer)

Name	Type	Range/Length	Comment
Power Module ID	Integer	1 to 99	
Main input volts – R	Integer	0 to 9999	0.1V
Main input volts – S	Integer	0 to 9999	0.1V

Main input volts – T	Integer	0 to 9999	0.1V
Power Module ID...	Integer	1 to 99	

3.3.21 PMC

Data: (UPS->Computer)

Name	Type	Range/Length	Comment
Power Module ID	Integer	1 to 99	
Main input current – R	Integer	0 to 9999	0.1A
Main input current – S	Integer	0 to 9999	0.1A
Main input current – T	Integer	0 to 9999	0.1A
Power Module ID...	Integer	1 to 99	

3.4 3Phase Set Commands

Command	Description
SIV	Set Inverter On/Off
CSR	Clear SRAM
STD	Set Date/Time to UPS
SDC	Dry Contact Configuration
CRS	Cancel Shutdown Restart
SOS	Set Output On/Off for 3Phase
BT1	Set the Bypass Tx Voltage by Method1
BT2	Set the Bypass Tx Voltage by Method2
IDC	Dry Contact Input Configuration

3.4.1 SIV for 3Phase

Data: (Computer->UPS)

Name	Type	Range/Length	Comment
Enable/Disable Inverter	Integer	1 to 2	1 = Enable 2 = Disable

Description: Enable/Disable Inverter.

3.4.2 CSR for 3Phase

Data: (Computer->UPS)

Name	Type	Range/Length	Comment

Description: Clear SRAM

3.4.3 STD for 3Phase

Data: (Computer->UPS)

Name	Type	Range/Length	Comment
Year	Integer	0 to 100	Since Year 2000
Month	Integer	1 to 12	
Day	Integer	1 to 31	
Hour	Integer	0 to 23	
Minute	Integer	0 to 59	

Second	Integer	0 to 59	
--------	---------	---------	--

Description:

3.4.4 **SDC** for 3Phase

Data: (UPS-> Computer)

Name	Type	Range/Length	Comment
Dry Contact Output Configuration	Binary Data	12 bytes	DryStatusW1 – DryStatusW6

Description:

The byte order is DryStatusW1(Lo), DryStatusW1(Hi), ..., DryStatusW6(Lo), DryStatusW6(Hi)

High Byte

B7: 0=Normal Open, 1=Normal Close

B5 ... B0: 0=None, 1=Dry Contact1, 2=Dry Contact2, ..., 6=Dry Contact6

Low Byte

B7: 0=Inactive, 1=Active

B6 ... B0: 0=None, 1=Event1, ... 20=Event20

3.4.5 **CRS** for 3Phase

Data: (Computer->UPS)

Name	Type	Range/Length	Comment
Cancel Shutdown Restart			

Description: Cancel Shutdown Restart.

3.4.6 **SOS** for 3Phase

Data: (Computer->UPS)

Name	Type	Range/Length	Comment
Set Output On/Off	Integer	1 or 2	1 = On 2 = Off

Description:

3.4.7 **BT1**

Data: (Computer->UPS)

Name	Type	Range/Length	Comment
Bypass Low Transfer Voltage	Integer	0 to 999	Volt
Bypass High Transfer Voltage	Integer	0 to 999	Volt

Description: Set the bypass Tx voltage by method1. Refer to RAT command for more information.

3.4.8 **BT2**

Data: (Computer->UPS)

Name	Type	Range/Length	Comment
Bypass Voltage Tolerance	Integer	0 to 999	Volt

Description: Set the bypass Tx voltage by method2. Refer to RAT command for more information.

3.4.9 **IDC** for 3Phase

Data: (UPS-> Computer)

Name	Type	Range/Length	Comment
Dry Contact Input Configuration	Binary Data	4 bytes	DryContact_in_1 – DryContact_in_2

Description:

The byte order is DryContact_in_1(Lo), DryContact_in_1(Hi), DryContact_in_2(Lo), DryContact_in_2(Hi)

High Byte

B7: 0=Normal Open, 1=Normal Close

B5 ... B0: 0=None, 1=Dry Contact_in_1, 2=Dry Contact_in_2

Low Byte

B7: 0=Inactive, 1=Active

B6 ... B0: 0=None, 1=Event1, ... 20=Event20

Appendix A: Examples

■ Regular Format:

Computer→UPS: ~00P003AVL

UPS→Computer: ~00D0131110101100000

Description: UPS support TST, UBR, TXV, RON, ROF and RNF but not support BUZ, RST, SDA, SDR, SDT, UID and VSN

Computer→UPS: ~00P003STI

UPS→Computer: ~00D006;;1102

Description: 006 - Number of data bytes
1102 - Input Voltage1 = 110.2 Volts

Computer→UPS: ~00S005SDA60

Description: 005 - Number of data bytes
SDA - Shutdown
60 - in 60 seconds

Appendix B: NT Event Code

0x00	Utility Voltage Abnormal
0x01	Utility Frequency Abnormal
0x02	Input Phase Sequency Abnormal
0x03	Rectifier Input Over Current
0x04	Rectifier Current Unbalance
0x05	Rectifier Over Temperature Warning
0x06	Rectifier Over Temperature Shutdown
0x07	Rectifier / Static Switch Fail
0x08	DC Bus Over Voltage
0x09	Battery Cabinet or Ambiance Over Temperature
0x0a	Battery Ground Fault
0x0b	Battery Test OK
0x0c	Battery Test Fail
0x0d	Battery Over Charge
0x0e	Battery Low Warning
0x0f	Battery Low Shutdown
0x10	Battery Replacement
0x11	Inverter Over Temperature Warning
0x12	Inverter Over Temperature Shutdown
0x13	Inverter Input Voltage Abnormal
0x14	Inverter Output Voltage Abnormal
//0x15	Inverter Frequency Abnormal
0x15	Inverter To Bypass PLL Abnormal // change on 03/20/2009
0x16	Inverter Overload
0x17	Inverter Overload Shutdown
0x18	Inverter Short Circuit
0x19	Inverter Fuse Fail
0x1a	Inverter Fail
0x1b	Bypass Voltage Abnormal
0x1c	Bypass Frequency Abnormal
0x1d	Bypass Phase Sequency Abnormal
0x1e	Static Switch Over Temperature
0x1f	Static Switch Overload
0x20	Static Switch Fail
0x21	EPO On
0x22	Inner Communication Abnormal
0x23	Parallel Communication Abnormal
0x24	Parallel Fail
0x25	Manual Bypass On
0x26	Output Transformer Over Temperature Shutdown
0x27	Input Transformer Over Temperature
0x28	Utility Voltage Normal
0x29	Utility Frequency Normal
0x2a	Input Phase Sequency Normal
0x2b	Rectifier Input Current Normal
0x2c	Rectifier Current Normal
0x2d	Rectifier Temperature Normal
0x2e	
0x2f	Rectifier / Static Switch Normal
0x30	DC Bus Voltage Normal
0x31	Battery Cabinet Temperature Normal
0x32	Battery Ground Normal
0x33	
0x34	

0x35 Battery Charger Normal
0x36 Battery Voltage Normal
0x37
0x38 Battery Has Been Changed
0x39 Inverter Temperature Normal
0x3a
0x3b Inverter Input Voltage Normal
0x3c Inverter Output Voltage Normal
0x3d Inverter Output Frequency Normal
0x3e Inverter Load Normal
0x3f
0x40 Inverter Circuit Normal
0x41 Inverter Fuse Normal
0x42 Inverter OK
0x43 Bypass Voltage Normal
0x44 Bypass Frequency Normal
0x45 Bypass Phase Sequence Normal
0x46 Static Switch Temperature Normal
0x47 Static Switch Load Normal
0x48 Static Switch OK
0x49 EPO Off
0x4a Inner Communication Normal
0x4b Parallel Communication Normal
0x4c Parallel Communication OK
0x4d Manual Bypass Off
0x4e Output Transformer Temperature Normal
0x4f Input Transformer Temperature Normal
0x50 Battery Test Start

0x80 Inverter Status: Inhibit UPS Output
0x81 Inverter Status: Bypass Mode
0x82 Inverter Status: Load On Inverter
0x83 Inverter Status: Backup Mode
0x84 Inverter Status: Remote Shutdown
0x85 Inverter Status: SSOP Due to V-RMS
0x86 Inverter Status: Feedback Loss
0x87 Inverter Status: DV/DT Abnormal
0x88 Inverter Status: SDA Command
0x89 Inverter Status: Bus OVP Happen
0x8a Inverter Status: R-Inverter Fuse Open
0x8b Inverter Status: S-Inverter Fuse Open
0x8c Inverter Status: T-Inverter Fuse Open
0x8d Inverter Status: R-Inverter High Temperature
0x8e Inverter Status: S-Inverter High Temperature
0x8f Inverter Status: T-Inverter High Temperature

Appendix C: NH Event Code

0x00	Mains Input Voltage Abnormal
0x01	Mains Input Frequency Abnormal
0x02	Mains Input Phase Sequence Abnormal
0x03	Mains Input Over Current
0x04	Mains input Current Unbalance
0x05	Rectifier (PFC) Over Temperature Warning
0x06	Rectifier (PFC) Over Temperature Shutdown
0x07	Rectifier Static Switch Fail
0x08	DC Bus Over Voltage
0x09	Battery Cabinet or Ambient Over Temperature
0x0a	Battery Ground Fault
0x0b	Battery Test OK
0x0c	Battery Test Fail
0x0d	Battery Over Charge
0x0e	Battery Low Warning
0x0f	Battery Low Shutdown
0x10	Battery Replacement
0x11	Inverter Over Temperature Warning
0x12	Inverter Over Temperature Shutdown
0x13	Inverter Input Voltage Abnormal
0x14	Inverter Voltage Abnormal
//0x15	Inverter Frequency Abnormal
0x15	Inverter To Bypass PLL Abnormal // change on 03/20/2009
0x16	Inverter Overload warning
0x17	Inverter Overload Shutdown
0x18	Inverter Short Circuit
0x19	Inverter Fuse Fail (open)
0x1a	Inverter fail
0x1b	Bypass Voltage Abnormal
0x1c	Bypass Frequency Abnormal
0x1d	Bypass Phase Sequence Abnormal
0x1e	Bypass Static Switch Over Temperature
0x1f	Bypass Static Switch Overload
0x20	Bypass Static Switch Fail
0x21	EPO On
0x22	Inner Communication Abnormal
0x23	Parallel Communication Abnormal
0x24	Parallel Fail
0x25	Manual Bypass On
0x26	Output Transformer Over Temperature Shutdown
0x27	Input Transformer Over Temperature
0x28	Mains Input Voltage Normal
0x29	Mains Input Frequency Normal
0x2a	Mains Input Phase Sequence Normal
0x2b	Mains Input Over Current Recovery
0x2c	Mains Input Current Unbalance Recovery
0x2d	Rectifier (PFC) Temperature Normal
0x2e	
0x2f	Rectifier Static Switch Normal
0x30	DC Bus Voltage Normal
0x31	Battery Cabinet Temperature Normal
0x32	Battery Ground Normal
0x33	
0x34	

0x35 Battery Charger Normal
0x36 Battery Voltage Normal
0x37
0x38 Battery Fully Charged
0x39 Inverter Temperature Normal
0x3a
0x3b Inverter Input Voltage Normal (DC bus?)
0x3c Inverter Voltage Normal
0x3d Inverter Frequency Normal
0x3e Inverter Load Normal
0x3f
0x40 Inverter Circuit Normal
0x41 Inverter Fuse Normal
0x42 Inverter OK
0x43 Bypass Voltage Normal
0x44 Bypass Frequency Normal
0x45 Bypass Phase Sequence Normal
0x46 Bypass Static Switch Temperature Normal
0x47 Bypass Static Switch Load Normal
0x48 Bypass Static Switch OK
0x49 EPO Off
0x4a Inner Communication Normal
0x4b Parallel Communication Normal
0x4c Parallel OK
0x4d Manual Bypass Off
0x4e Output Transformer Temperature Normal
0x4f Input Transformer Temperature Normal
0x50 Battery Test In Progress
0x51 PFC circuit fault shutdown
0x52 Inverter circuit fault shutdown
0x53 PFC soft start fault shutdown
0x54 Inverter soft start fault shutdown
0x55 PFC fuse open
0x56 Inverter static switch failure
0x57 DC bus over voltage warning
0x58 DC bus over voltage shutdown
0x59 DC bus normal
0x5A DC bus under voltage warning
0x5B DC bus under voltage shutdown
0x5C Output voltage abnormal shutdown
0x5D Power module Fan failure
0x5E System Fan failure
0x5F Power module Charger fail
0x60 System Charger fail
0x61 Aux Power fail
0x62 System to System Not Compatible
0x63 System to Module Not Compatible
0x64 Module to Module Not Compatible
0x65 PFC/INV Not Compatible
0x66 PFC EEPROM error
0x67 INV EEPROM error
0x68 PFC EEPROM not calibrated
0x69 INV EEPROM not calibrated
0x6a INV fuse open
0x6b battery bad
0x6c INV over current
0x6d System Parallel ID conflict

0x6e redundancy loss
0x6f Output breaker off
0x70 Bypass load over 104%
0x71 PM ID fail
0x72 IP TR overheat
0x73 OP TR overheat
0x74 External Battery Breaker Off
0x75 Power Module CAN Abnormal
0x76 Power Module Data Bus Abnormal
0x77 Power Module Inter Block Abnormal
0x78 Power Module Repair On
0x79 Power Module Repair Off
0x7a ECO Voltage Normal
0x7b ECO Voltage Abnormal
0x7c Power Module PFC Not Ready
0x7d Fan Filter Need Replace
0x7e Power Module Battery Fuse Open
0x80 Inverter Status: Inhibit UPS Output
0x81 Load on Bypass
0x82 Load On Inverter
0x83 Backup Mode
0x84 Remote Shutdown
0x85 Inverter Status: SSOP Due to V-RMS
0x86 Inverter Status: Feedback Loss
0x87 Inverter Status: DV/DT Abnormal
0x88 Inverter Status: SDA Command
0x89 Inverter Status: Bus OVP Happen
0x8a Inverter Status: R-Inverter Fuse Open
0x8b Inverter Status: S-Inverter Fuse Open
0x8c Inverter Status: T-Inverter Fuse Open
0x8d Inverter Status: R-Inverter High Temperature
0x8e Inverter Status: S-Inverter High Temperature
0x8f Inverter Status: T-Inverter High Temperature
0x90 ECO mode

Appendix D: Shutdown Reason

0x00 Power fail
0x01 Main phase sequency abnormal
0x02 Battery low
0x03 Command shutdown
0x04 EPO on
0x05 DCBUS UVP
0x06 DCBUS OVP
0x07 PFC soft start fail
0x08 Over temperature
0x09 Charger fail
0x0a FAN fail
0x0b Aux power fail

0x10 Input SCR short
0x11 Input fuse fail
0x12 Input transformer overtemp

0x20 Output transformer overtemp
0x21 Output fuse fail
0x22 Output fail

0x30 Inverter limitation
0x31 Inverter voltage fail
0x32 Inverter short
0x33 Inverter overload shutdown
0x34 Inverter output voltage abnormal
0x35 Inverter fuse fail
0x36 Inverter over temp. shutdown
0x37 Inverter SCR Fault
0x38 Inverter soft start fail

0x40 Bypass SCR short
0x41 Bypass phase sequency abnormal
0x42 Bypass SCR open
0x43 Bypass SCR overtemp

0x50 Sys/HW incompatible
0x51 System parallel comm. abnormal
0x52 System parallel ID conflict
0x53 System/System parallel incompatible
0x54 Sys/module incompatible
0x55 Module/module incompatible
0x56 Power module ID fail

0x60 System power supervisor & H/W_watch_dog
0x61 Inner communication fault

Appendix E: Application Note

1. UPS Inquiry Commands

“AVL” Get Available Commands

This command must be supported in all UPS models, the application software polling for this command to know how many commands are supported then prepare the related commands to get the proper values. The new available commands of AL1, AL2 and AL3 are design for the new 3Phase additional commands, if the unit does not support such kind of commands then it should return reject (~00R).

“MNU” Get Manufacturer Name

Sending the MNU causes the UPS to respond with the manufacturer name.

“MOD” Get Model Name

This command must be supported in all UPS models, Sending the MOD causes the UPS to respond with a less than 16 ASCII character string consisting of the UPS model name.

The second parameter is used to identify the 3Phase UPS series.

Series	Meaning of Value
0	T-Series
1	H-Series
2	NT-Series
3	NH-Series

Example: ~00D017GES-203NH110100;3

“RAT” UPS Nominal Values

Sending the RAT causes the UPS to respond with a series values representing the UPS's nominal rating. This is not the UPS's actual parameter values, which is reported by the STI, STO, STB,... command.

Mains Transfer Voltage: The UPS's mains input transfer voltages threshold that triggers the UPS to change from on-line to on-battery operation.

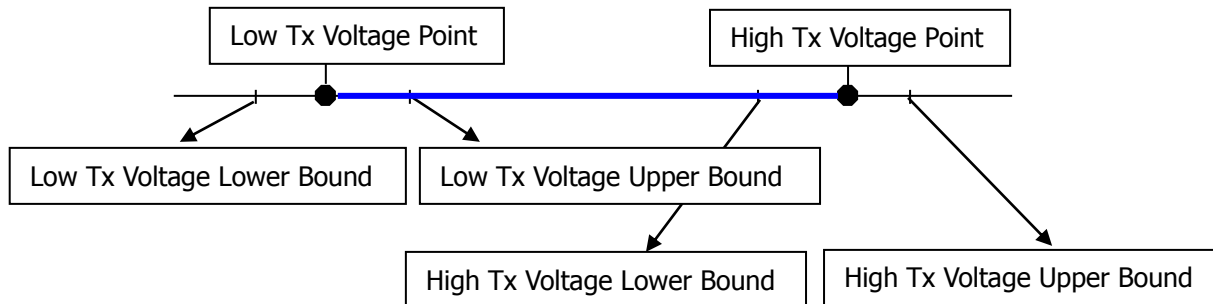

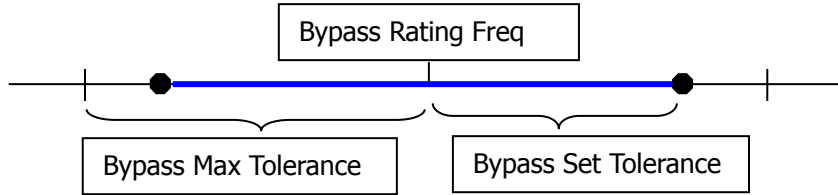

Bypass Transfer Voltage: The UPS's bypass transfer voltages threshold that triggers the UPS to change from on-bypass to on-line operation in economic mode or turn the output off if the UPS is in bypass mode.

- ◆ **Method1:** If the UPS supports the following 6 items: “Bypass Low Tx Voltage Point “, “Bypass High Tx Voltage Point “, “Bypass Low Tx Voltage Upper Bound”, “Bypass Low Tx Voltage Lower Bound”, “Bypass High Tx Voltage Upper Bound” and “Bypass High Tx Voltage Lower Bound” then the setting scenario is the same as Input Tx Voltage. The related command is BT1.
- ◆ **Method2:** If the UPS only supports “Bypass Rating Voltage”, “Bypass Voltage Max Tolerance” and “Bypass Voltage Set Tolerance” then the setting scenario is the same as Bypass Frequency Tolerance. The related command is BT2.

“SDT” UPS Shutdown Type

This command is obsolete in Delta UPS but if the UPS is design for TrippLite then this command should be supported. Reject this command causes the PA to stop poling and show communication disconnection. Sending the SDT causes the UPS to respond with a shutdown type.

“STB” Battery Status and Parameters

Sending the STB causes the UPS to respond with battery status and parameter values.

Battery Condition: If the input power is normal and the battery is normal then UPS replies Good(0). If input power normal but battery low then Weak(1) is replied. Battery replacement alarm is caused by the battery test, battery open event or the next replacement date(BRD) is expired.

Battery Status: If the UPS is not in battery mode then OK(0) is replied. If it is in backup mode and battery reached low level then Low(1) is replied. The UPS reply Depleted(2) when the battery reaches low battery shutdown level.

Battery Charge: Representing the battery charge status.

Charge	Meaning of Value
0	Obsolete
1	Charging (The battery is in charging)
2	Resting: The UPS is not in charging or discharging state.
3	Discharge: The UPS is performing battery test or in battery mode.

Seconds on Battery: Representing the UPS's on battery time in seconds, the UPS should return 0 when the unit is not in battery mode.

Estimated Minutes Remaining: Representing the UPS's estimated remaining run time in minutes You can

query the UPS when it is operating in the on-line, bypass, or on-battery modes of operation. The UPS's remaining run time reply is based on available battery capacity and output load.

UPS Internal Temperature: The temperature value that is measured in the UPS internally.

“STI” Input Power Parameters

Sending the STI causes the UPS to respond with input power parameter values.

Input Num Lines(Phases): Representing the phase number of input lines. Single phase returns 1, split phase returns 2 and 3 phase returns 3.

“STO” Output Power Parameters

Sending the STO causes the UPS to respond with output power parameter values.

Output Source: Representing the UPS operation mode.

Source	Meaning of Value
0	Normal: The UPS is turned on and operating in normal situation.
1	Battery: The output is supplied by battery. It is in battery mode.
2	Bypass(Reserve): The UPS is transferred to bypass mode. 3Phase UPS is in reserve mode.
3	Reducing: Buck mode.
4	Boosting: Boost mode.
5	Manual Bypass: 3Phase manual bypass mode.
6	Other: Unknown state.
7	No Output: No output power.

Output Num Lines(Phases): Representing the phase number of output lines.

“STP” Bypass Power Parameters

Sending the STP causes the UPS to respond with bypass power parameter values.

Bypass Num Lines(Phases): Representing the phase number of bypass lines.

“STA” UPS Alarm Status

Sending the STA causes the UPS to respond with operational status.

Alarm Over Temperature: Representing one of the temperature sensors has been determined its value is over limit.

Alarm Input Out Of Range: Representing the input power is out of tolerance. This item is used to indicate the input power fail, a test condition should not set this item on.

Alarm Overload: The output load exceeds the UPS output capacity.

Alarm Bypass Out Of Range: The bypass power is out of range.

Alarm Output Off: The UPS output is turned off.

Alarm UPS Shutdown: The UPS has been shutdown including remote and fault shutdown. For example:

The software issues the schedule shutdown and restart commands, the UPS then countdown to

shutdown and is counting the restart timer to restart. Including fault shutdown...

To know more about the shutdown reason, users inquiry the DWR command to get the reason code from UPS, it DWR command is supported by the UPS.

Alarm Charger Fail: An uncorrected problem has been detected within the UPS charger subsystem.

Alarm Standby: The UPS system is in the standby state. For example: The UPS get the input power but does not startup the system.

Alarm Fan Fail: The failure of one or more fans in the UPS has been detected.

Alarm Fuse Fail: The failure of one or more fuses has been detected.

Alarm Other Warning: To indicate there is an alarm detected but which is not defined by STA.

Alarm Awaiting Power: The UPS is shutdown due to low battery shutdown or receive shutdown command in battery mode and the UPS is awaiting the return of input power.

Alarm Shutdown Pending: A shutdown UPS command SDA is received and countdown is underway. Or the dry-contact shutdown signal is activated.

Alarm Shutdown Imminent: The UPS will turn off power to the load in less than 5 seconds; this may be either a timed shutdown or a low battery shutdown.

Alarm Buzzer Status: To indicate the UPS buzzer is currently alarming.

Economic Mode: The UPS is working in the economic mode (act like an off-line UPS).

Alarm Inverter Fail: Representing the inverter fail alarm.

Emergency Power Off: Representing the UPS is shutdown due to the Emergency Power Off button is pressed.

Alarm Buzzer State: To indicate the UPS buzzer is enabled or disabled.

Battery Ground Fault: To indicate the battery ground fault has been detected.

Alarm Output Voltage Over Limit: To indicate the output voltage is over limit.

Alarm Output Voltage Under Limit: To indicate the output voltage is under limit.

Alarm Power Module: To indicate there is at least one alarm from power module.

Alarm Output Breaker Open: To indicate the output breaker is detected open or close.

“TSR” Test Result

Sending the TSR causes the UPS to respond with the battery test result. The battery test command in this protocol is TST.

Result	Meaning of Value
0	No Test Performed: Representing the UPS does not perform battery test.
1	Test Passed: Indicate the battery test passed last time.
2	Test in Progress: Indicate the UPS is performing battery test.
3	Obsolete
4	Battery Test Fail: Indicate the battery test failed last time.
5	Obsolete
6	Test Aborted: Representing the test process was aborted last time.

Test Aborted: This situation may be caused by the TST0 command or there is a power event or component fail occurs during test process.

“VER” UPS Firmware Version String

Sending the VER causes the UPS to respond with the UPS firmware version string.

“TXV” Transfer Voltage

Sending the TXV causes the UPS to respond with the high transfer voltage and low transfer voltage. The ranges of high transfer voltage and low transfer voltage are defined in RAT command. Both of the values should not exceed its range and these values have to keep in EEPROM.

“VSN” Voltage Sensitivity

You can customize the UPS's sensitivity to rapid changes in utility voltage (e.g. blackouts, spikes or notches) or abnormal changes in utility frequency to allow use of the UPS in "noisy" electrical environments or with fuel powered generators where the UPS may otherwise frequently transfer to onbattery operation. Sending the VSN causes the UPS to respond with the UPS's current utility failure sensitivity setting as shown in the following table. The "0" or Normal setting provides the best protection from all utility voltage vagaries. Select the "1" or Reduced setting where rapid low amplitude line voltage fluctuations commonly occur as the result of motor load switching in air conditioners, elevators, etc. Select the "2" or Low setting when the UPS is operated in a "noisy" electrical environment or from an inexpensive fuel-powered generator.

Sensitivity	Meaning of Value
0	Normal: Highest sensitivity to utility voltage fluctuations
1	Reduced: Medium sensitivity to utility voltage fluctuations
2	Low: Lowest sensitivity to utility voltage fluctuations

“LET” Number of Output Relay

Indicates the number of output relay. Each output relay is switchable by RON and ROF commands and the relay state can be observed by SOL command. The UPS does not need to support these output relay commands if it has only one output relay.

“SOL” Number of Output Relay

Representing current state of the switchable output relay. Response 0 indicates a controllable relay is on. The polling command needs to indicate the relay index. An example is ~00P004SOL2, which is used to query the state of second output relay. The UPS may return ~00D0010, which means the state of the second output relay is on. Each output relay may control several outlets in the rear panel of UPS. If the UPS model only supports 1 output relay then it is not necessary to support this command.

“BRD” Battery Replacement Date

Sending the BRD causes the UPS to respond with 2 sets of eight characters in the format "YYYYMMDD" (year, month, day), directly representing the date the UPS's battery was last replaced and next replacement. The application software uses the information to notify end user when to replace the UPS battery. The last replacement date and next replacement date need to be filled when the UPS is produced in the factory.

“ATT” Auto Test Period

You can customize the UPS to run the automatic battery test every day, weekly, biweekly and monthly, or never. Sending the ATT causes the UPS to respond with a number representing the current automatic battery test setting as shown in the following table. The Automatic Battery Test setting does not affect the function of the UPS's Test push-button (where applicable) and the Battery Test command TST.

Period	Meaning of Value
1	Disable
2	Daily
3	Weekly
4	Biweekly
5	Monthly

“ARB” Battery Mode Shutdown Auto Reboot

In battery mode, the UPS may shutdown normally by SDA command, dry-contact remote shutdown signal or low battery shutdown. This command is used to determine the unit should restart or not next time when the power restores.

“TXF” Bypass Frequency Tolerance

Sending the TXF causes the UPS to respond with the bypass frequency tolerance. If the bypass rating frequency is 60Hz and the UPS response 20(+2Hz) to TXF command, that means the UPS should turn off the output when it is on bypass and the bypass frequency is not in the 58~62 Hz.

“UBD” UPS Boot Delay

Delay the UPS startup after power restores. The power quality may not stable when power restores, this feature lets the UPS wait a period of time to startup the system. Sending the UBD causes the UPS to respond with the UPS's current Turn On Delay setting in seconds.

“BTV” Customized Battery Test

This command is the same as 3Phase protocol. If battery voltage is lower than the “Test Voltage” during the “Test Time” which is set by users then the UPS reports test fail. This kind of battery test is triggered by TST(2) command.

“EPO” State of Emergency Power Off

Representing the state of emergency power off function is enable or disable. To indicate the UPS is shutdown due to the EPO button is pressed, the Emergency Power Off flag should set to 1 in STA command.

If the EPO function is disabled then the EPO button is not functional until it is set to enable.

“CPU” Communication Protocol of the Unit

This command is used to identify the protocol supported by the special models. TrippLite models need this command for PowerAlert to identify which commands are supported.

CPU	Meaning of Value
“4001”	New On-line
“4002”	Split phase
“5001”	NH series
“4100”	NH without checksum

“SER” Serial Number

Sending the SER causes the UPS to respond with a string of at most 20 characters directly representing the UPS's serial number as set at the factory.

“DWR” Shutdown Reason

Sending the DWR causes the UPS to respond with a sequence of shutdown reasons. Each shutdown reason includes 2 numbers, the first number is major code and the second number is sub-code. The major code indicates the known failure in all of the models and the sub-code is used to provide more detail information on the major code. Please refer to [Appendix D](#) for reason code.

“AEL” Event Log Type

Sending the AEL causes the UPS to respond with 3 numbers for event log length, supported format and command type.

Format	Meaning of Value
0	NT 9 byte format
1	NH 8 byte format
2	Online 6 byte format

Type	Meaning of Value
0	ELS
1	EVT

“EVT” Event Log for Index

Sending the EVT with event index number (starting from 1) and length of events causes the UPS to respond with content of the specified range.

Format	Meaning of Value
NT 9 byte	IndexWord(Lo), IndexWord(Hi), Year(2000+YY), Month, Day, Hour, Minute, Second,

	Event_Code (Appendix B)
NH 8 byte	Module_ID_EVENT_OCCURRED, Year(2000+YY), Month, Day, Hour, Minute, Second, Event code (Appendix C)
Online 6 byte	LifeTime(4 bytes in second), major code, sub-code

Module_ID_EVENT_OCCURRED = 0x00, event occurs in system

Module_ID_EVENT_OCCURRED >= 0x01, event occurs in power module #

“ELS” Event Log for Segment

This command is used to compatible with 3Phase protocol. Sending the ELS with segment index number (starting from 1) causes the UPS to respond with content of the specified segment. Each length of the segment is less than 200 bytes.

For NT 9 byte format, there is $9 \times 500 = 4500$ bytes. $4500/200=22.5$, up to 23 segments.

“TME” UPS Time

Sending the TME causes the UPS to respond with the internal time string.

Format	Meaning of Value
1	Life Time in Second
2	Date/Time

Life Time in Seconds: Accumulated life time in seconds

Date/Time: YYYYMMDDhhmmss

“CHS” Get the List of Charger Steps

Sending the CHS causes the UPS to respond with supported the list of charger steps and the current selected.

For example1: If the UPS replies ~00D0211;AUTO;1.0A;2.0A;3.0A

Then the UPS’s charger steps are as the following table and the current selection is AUTO.

Selected	Index	Charger Sep
Yes	1	AUTO
	2	1.0A
	3	2.0A
	4	3.0A

For example2: If the UPS replies ~00D0212;1.0A;2.0A;3.0A;4.0A

Then the UPS’s charger steps are as the following table and the current selection is fixed to 2.0A.

Selected	Index	Charger Sep
	1	1.0A
Yes	2	2.0A
	3	3.0A
	4	4.0A

2. UPS Set Commands

“BUZ” Set Buzzer Alarm/Silence

Sending the BUZ with a parameter number causes the UPS to sound or mute the buzzer as the following table.

Buzzer	Meaning of Value
1	Buzzer Alarm
2	Buzzer Silence

Once the UPS detects a warning situation that needs to notify users. First we have to check the EDB flag which indicates the buzzer is enabled or disabled by the user. If the EDB flag is enabled then the UPS start to sound the buzzer and sets the Buzzer Status flag to 1 in STA. Otherwise, the UPS remains silence.

During the UPS sounds the buzzer, once it receives the BUZZ2(Buzzer Silence) command the UPS should stop sounding the buzzer until next warning situation is detected and sets the Buzzer Status flag to 0 in STA. If the buzzer alarm is suppressed by BUZZ2 command then sends BUZZ1(Buzzer Alarm) command to the UPS to sound the buzzer again.

For Example: The UPS goes to on battery mode and sounds the buzzer, the user issues the BUZZ2 command to let the UPS keep silent but if the UPS continues to run to low battery then low battery event causes the UPS to sound the buzzer again and which could be muted again by issuing the BUZZ2 command.

“SDA” Set Shutdown Delay

Sending the SDA with a parameter number causes the UPS to turn off based on the parameter number which indicates the Shutdown Delay in second. The UPS accepts this command in online, battery and bypass modes and if there are several SDA commands are received, the UPS always executes the last SDA command. Sending the SDA0 causes the UPS to cancel the shutdown process.

On Battery Shutdown: Sending the SDA to the UPS while operating on-battery causes the UPS to shut down following a shutdown delay. The UPS's output returns based on the [ARB](#) command when the utility power is restored. **In the ARB enable condition**, if the utility power is restored within the UPS shutdown delay interval, the UPS still shuts down at the end of the interval and then delays more than 1 second(used to turn off the computer completely) to restart based on the ARB command. **In the ARB disable condition**, if the utility power is restored within the UPS shutdown delay interval, the UPS still shuts down at the end of the interval and remains shutdown.

Schedule Shutdown and Restart: The software sends a [SDR](#) command to preserve a restart timer before the SDA command to shutdown the UPS. Once the UPS shutdown it continues to count down the restart timer and if the restart timer reaches 0 the UPS's output returns. If the utility power fails during the the countdown the UPS should continue countdown to a safe battery voltage level (say 12V). Next time when the power restores the UPS **remains in the OFF state returns to the ON state**.

“SDR” Set Restart Delay

Sending the SDR with a parameter number causes the UPS to turn on based on the parameter number which indicates the Restart Delay in minute. The UPS accepts this command in online, bypass and standby modes and if there are several SDR commands are received, the UPS always executes the last SDR command. Sending the SDR65535 causes the UPS to cancel the restart process.

Schedule Shutdown and Restart: Please refer to the [SDA](#) command.

Standby Restart: The SNMP card may send the SDR command in standby mode to restart the UPS remotely.

“TST” Set Battery Test

Sending the TST with a parameter number causes the UPS to perform the different type of battery test as the following table. The UPS accepts this command in online mode and the battery capacity is 100% or the battery has been charged over 1 day.

Type	Meaning of Value
0	Abort Test
1	
2	BTV Test
3	Test for 10 seconds
4	Test until battery low

Abort Test: Sending the TST0 to force the UPS to stop the battery test process and the TSR should response 6 to indicate the test process is aborted.

BTV Test: You can customize the battery test process by setting the battery test time and the battery voltage threshold. The BTV parameters should be kept in EEPROM. Sending the TST2 causes the UPS to discharge the battery for the assigned BTV time and if the battery voltage is lower than the BTV voltage during the test process then the battery is determined to be failed.

Test for 10 seconds: Sending the TST3 causes the UPS to discharge the battery in 10 seconds. If the battery voltage is lower than the battery low voltage then the battery is determined to be failed.

Test until battery low: Sending the TST4 causes the UPS to discharge the battery until battery low. During the test process, the UPS calculates the battery capacity by AH and if the calculated AH is not exceed 30% of the rating battery AH then the battery is determined to be failed.

If the battery is determined fail during the test process, the UPS illuminates the battery replace LED, replies 4 or 5 to the TSR command to indicate the battery test fail.

“TXV” Set Transfer Voltage

Sending the TXV with 2 parameter values causes the UPS to change the high transfer voltage and low transfer voltage. The ranges of high transfer voltage and low transfer voltage are defined in RAT command. Both of the transfer voltage values should not exceed its range and these values have to keep in EEPROM.

On-Line model: In On-Line UPS the transfer voltages represents upper and lower limit for bypass.

Line-Interactive or Off-Line model: In Line-Interactive or Off-Line UPS the transfer voltages represents upper and lower limit for input. Once the input voltage is out of range, the UPS goes to battery mode to

supply the output power from battery.

“VSN” Set Voltage Sensitivity

You can customize the UPS's sensitivity to rapid changes in utility voltage (e.g. blackouts, spikes or notches) or abnormal changes in utility frequency to allow use of the UPS in "noisy" electrical environments or with fuel powered generators where the UPS may otherwise frequently transfer to onbattery operation. Sending the VSN with a parameter value causes the UPS to change the sensitivity setting as shown in the following table. The "0" or Normal setting provides the best protection from all utility voltage vagaries. Select the "1" or Reduced setting where rapid low amplitude line voltage fluctuations commonly occur as the result of motor load switching in air conditioners, elevators, etc. Select the "2" or Low setting when the UPS is operated in a "noisy" electrical environment or from an inexpensive fuel-powered generator.

Sensitivity	Meaning of Value
0	Normal: Highest sensitivity to utility voltage fluctuations
1	Reduced: Medium sensitivity to utility voltage fluctuations
2	Low: Lowest sensitivity to utility voltage fluctuations

“RON” Set Output Relay On

Sending the RON with 2 parameter values causes the UPS to turn the specified index of output relay to the ON state.

Outlet Relay Number: The first parameter value indicates the index of the output relay, starting from 1.

Delay Time: The second parameter value is the turn on delay time in second.

“ROF” Set Output Relay Off

Sending the ROF with 2 parameter values causes the UPS to turn the specified index of output relay to the OFF state.

Outlet Relay Number: The first parameter value indicates the index of the output relay, starting from 1.

Delay Time: The second parameter value is the turn off delay time in second.

“RNF” Set Output Relay On then Off

Sending the RNF with 3 parameter values causes the UPS to turn the specified index of output relay to the OFF state then turn on.

Outlet Relay Number: The first parameter value indicates the index of the output relay, starting from 1.

Turn Off Delay Time: The second parameter value is the turn off delay time in second.

Turn On Delay Time: The third parameter value is the turn on delay time in minute.

“BRD” Set Battery Replacement Date

Sending the BRD with 2 sets of eight characters in the format "YYYYMMDD" (year, month, day) causes the

UPS to change the battery replacement dates. The application software uses the information to notify end user when to replace the UPS battery. The last replacement date and next replacement date need to be filled when the UPS is produced in the factory.

“ECO” Set Economic Mode

Sending the ECO with a parameter value causes the UPS to enter the economic mode as the following table.

ECO	Meaning of Value
1	Goto ECO mode
2	Back from ECO mode

“ATT” Set Auto Test Period

You can customize the UPS to run the automatic battery test every day, weekly, biweekly and monthly, or never. Sending the ATT with a parameter value causes the UPS to set the automatic battery test setting as shown in the following table. The parameter value needs to be kept in EEPROM.

Period	Meaning of Value
1	Disable
2	Daily
3	Weekly
4	Biweekly
5	Monthly

“BTT” Buzzer Test

Sending the BTT with a parameter value causes the UPS to sound the buzzer for the specified seconds.

“ARB” Set Battery Mode Shutdown Auto Reboot

In battery mode, the UPS may shutdown normally by SDA command, dry-contact remote shutdown signal or low battery shutdown. This command is used to determine the unit should restart or not next time when the power restores as the following table.

Type	Meaning of Value
1	Enable: The UPS restarts when power restores.
2	Disable: The UPS does not restart when power restores.

“UBD” Set UPS Boot Delay

Delay the UPS startup after power restores. The power quality may not stable when power restores, this feature lets the UPS wait a period of time to startup the system. Sending the UBD with a parameter number causes the UPS to store the UPS's current Turn On Delay setting in the specified seconds in EEPROM.

“TXF” Set Bypass Transfer Voltage

Sending the TXF with a parameter number causes the UPS to change the tolerance of bypass transfer frequency. If the parameter number is 15 and the rating frequency is 60Hz then the transfer frequency range

for bypass is between 60+-1.5 Hz, that is 58.5Hz~61.5Hz.

“EDB” Enable/Disable UPS Buzzer

Sending the EDB with a parameter number causes the UPS to set the buzzer enabled or disabled and save this flag in EEPROM. If the EDB flag is disabled then the UPS does not sound the buzzer anymore. Please refer to [BUZ](#) command for more description on buzzer operation.

“BTV” Customize Battery Test

Sending the BTV with 2 parameter values causes the UPS to set the test time and test voltage in EEPROM. Sending the TST2 causes the UPS to discharge the battery for the assigned BTV time and if the battery voltage is lower than the BTV voltage during the test process then the battery is determined to be failed.

“EPO” Set State of Emergency Power Off

Sending the EPO with a parameter number causes the UPS to change the state of EPO. This EPO state flag should be kept in EEPROM and reply to the EPO inquiry command.

The flag of Emergency Power Off in STA command indicates the UPS is shutdown due to the EPO button is pressed. It is different from the EPO state flag.

“EBP” Set External Battery Pack

Sending the EBP with a parameter number causes the UPS to set the number of external battery pack in EEPROM. The UPS then calculate the battery remaining time and battery capacity based on the number of its internal and external battery.

“CLR” Clear the Specified Object

Sending the CLR with a parameter number causes the UPS to clear the specified object. The object is listed in the following table:

Object	Meaning of Value
1	Event log
2	Life time

“CHS” Set Charger Step

Sending the CHS with a parameter number causes the UPS to set the specified index of charger steps. To get the list of charger steps please send the querying of CHS command.

Appendix E: Obsolete Command

UPS Inquiry Commands

3.1.15 UBR

Data: (UPS->Computer)

Name	Type	Range/Length	Comment
Baud Rate	Integer	See Comment	1200,2400,4800,9600

Default: 2400

3.1.16 UID

Data: (UPS->Computer)

Name	Type	Range/Length	Comment
UPS Identification	Integer	0 to 99	Used for one PC connect to multi-UPS

Default: 0

3.1.23 ENV

Data: (UPS->Computer)

Name	Type	Range/Length	Comment
Temperature	Integer	0 to 999	Degree Celsius
Humidity	Integer	0 to 999	Sensor Box Humidity
Input Contact1	Integer	0 or 1	0: Off, 1: On
Input Contact2	Integer	0 or 1	0: Off, 1: On
Input Contact3	Integer	0 or 1	0: Off, 1: On
Input Contact4	Integer	0 or 1	0: Off, 1: On

“UBR” Communication Baud Rate

Sending the UBR causes the UPS to respond with the communication baud rate.

This command is reserved for further used.

“UID” UPS ID

Sending the UID causes the UPS to respond with the ID number. UPS ID is used to identify several UPSs in the same communication bus or parallel bus. The UPS always responses the ID=0 packet from SNMP slot and RS232 communication port even if its ID is different from 0. That means if users want to cascade several UPSs in the same bus then the ID number for each UPS should be different and greater than 1.

“ENV” Environment Sensor

This command is designed for environment sensor box. This sensor box includes temperature and humidity sensors inside and has 4 additional input contacts for receiving external sensor through dry contact.

UPS Set Commands

3.2.6 UBR

Data: (Computer->UPS)

Name	Type	Range/Length	Comment
Baud Rate	Integer	See Comment	1200,2400,4800,9600

Description: Sets UPS baud rate.

3.2.7 UID

Data: (Computer->UPS)

Name	Type	Range/Length	Comment
UPS Identification	Integer	0 to 99	

Description: Sets UPS ID for one PC monitor more than one UPS.

“UBR” Set UPS Baud Rate

Sending the UBR with a parameter number causes the UPS to change the communication baud rate from next packet. This command is reserved for further used.

“UID” Set UPS ID

Sending the UID with a parameter number causes the UPS to change its ID number. UPS ID is used to identify several UPSs in the same communication bus or parallel bus. The UPS always response the ID=0 packet from SNMP slot and RS232 communication port even if its ID is different from 0. That means if users want to cascade several UPSs in the same bus then the ID number for each UPS should be different and greater than 1.

Appendix F: Auto Test Command for Production

The following commands are design for the ATS(automatic test system) in production.

UPS Inquiry Commands

ATC

Data: (UPS->Computer)

Name	Type	Range/Length	Comment
SNMP Self Test Result	Integer	0 to 3	0: None 1: Testing 2: Fail 3: Success

TCA

Data: (Computer->UPS)

Name	Type	Range/Length	Comment
Temperature1	Integer	-100~100	
Temperature2	Integer	-100~100	
Temperature3	Integer	-100~100	
Temperature4	Integer	-100~100	
...	Integer	-100~100	

Description:

All of the detected temperature values in UPS including heatsink.

TCB

Data: (Computer->UPS)

Name	Type	Range/Length	Comment
Inverter Voltage	Integer	0~9999	
Bus Voltage(+)	Integer	0~9999	
Bus Voltage(-)	Integer	0~9999	
Charger Voltage(+)	Integer	0~9999	
Charger Voltage(-)	Integer	0~9999	
Charger Current(+)	Integer	0~9999	
Charger Current(-)	Integer	0~9999	

Description:

Return DC bus voltage, inverter voltage, charger voltage.

TCC

Data: (UPS->Computer)

Name	Type	Range/Length	Comment
------	------	--------------	---------

...	Integer	0 or 1	0 = OK 1 = Fail
-----	---------	--------	--------------------

Description:

Return the specified alarm which is defined by TE. If TE needs UPS to provide the other alarm which is not defined in the STA then the specified alarm should be place in the TCC command.

TCD

Data: (UPS->Computer)

Name	Type	Range/Length	Comment
Burn in accumulated power	Integer	0~9999999	Watt-Hour

Description:

Return burn in accumulated output power in watt-hour.

TCZ

Data: (UPS->Computer)

Name	Type	Range/Length	Comment
TBD	TBD	TBD	TBD

Description:

User defined ATS testing inquiry command for certain special function.

UPS Set Commands**ATC**

Data: (Computer->UPS)

Name	Type	Range/Length	Comment
Auto Test Command	Integer	0 to 3	0: Cancel SNMP Self Test 1: SNMP Self Test 2: Cancel Buzzer/LED Test 3: Buzzer/LED Test

Description:**SNMP self test:**

Purpose: PE needs UPS to auto test the Tx/Rx connection to decrease the production time.

Method: 1. Insert the PE tooling in the SNMP card to short the Tx and Rx path.

2. The PC sends ~00S004ATC1xx to UPS where xx is checksum.

3. When UPS receives the command, the UPS sends a pre-defined package from Tx and receives from Rx. If the received data is the same as the transmitted data, the test result is passed. If the received data is not the same as the transmitted data or after a defined time, the UPS doesn't receive any data, the result is fail.

4. The PC sends ~00P003ATCxx to get the test result where xx is checksum.

Buzzer/LED test:

Purpose: PE needs UPS to show buzzer and LED function through communication.

Method: 1. The PC sends ~00S004ATC3xx to UPS where xx is checksum.

2. The UPS plays buzzer and LED pattern.

Buzzer: Continuously on for 10 seconds.

LED: The LED should turn on/off one by one sequentially.

TC0

Data: (Computer->UPS)

Name	Type	Value	Comment
Test Command 0	Integer	0 or 1	0: Leave test mode 1: Enter test mode

Description:

This command can be accepted at any state of UPS, the flag should not be kept in the EEPROM and should be clear to 0 when the UPS is in the off state.

This flag indicates that the UPS is under production test, some of functions can be ignored at the softstart stage to reduce the test time.

TC1

Data: (Computer->UPS)

Name	Type	Value	Comment
LED Test Command	Integer	0 or 65535	16 bits: Each bit relate to a specific LED on/off state 0: LED off 1: LED on

Description:

This command can be accepted only in the test mode. It is used to control the LED on/off respectively. The value maps to a 16 bits integer, each bit links to a LED on/off state which can be control by the ATS. Based on this function, the ATS can design a total on, total off or sequential on/off for LED test.

The UPS remains the LED indication in **10 seconds for each TC1 command**, after that the LED will return back to reflect the UPS status.

TC2

Data: (Computer->UPS)

Name	Type	Value	Comment
------	------	-------	---------

Dry Contact Test Command	Integer	0 or 65535	16 bits: Each bit relate to a specific dry contact state 0: Open 1: Close
--------------------------	---------	------------	---

Description:

This command can be accepted only in the test mode. It is used to control the dry contact on/off respectively. The value maps to a 16 bits integer, each bit links to a dry contact state which can be control by the ATS.

The UPS remains the dry contact indication in **10 seconds for each TC2 command**, after that the dry contact will return back to reflect the UPS status.

TC3

Data: (Computer->UPS)

Name	Type	Value	Comment
EEPROM	Integer	0 or 1	0: EEPROM write 1: EEPROM reload

Description:

This command can be accepted only in the test mode. It is used to control the dry contact on/off respectively. The value maps to a 16 bits integer, each bit links to a dry contact state which can be control by the ATS.

The UPS remains the dry contact indication in **10 seconds for each TC2 command**, after that the dry contact will return back to reflect the UPS status.

TC4

Data: (Computer->UPS)

Name	Type	Value	Comment
Battery Open Detection	Integer	1 or 2	1: Enable 2: Disable

Description:

This command can be accepted only in the test mode. Disable the battery open detection function for PE to test the charger voltage and current.

TC5

Data: (Computer->UPS)

Name	Type	Value	Comment
------	------	-------	---------

Burn in period of time setting and clear burn in accumulated output power	Integer	0~99	0: Disable burn in power accumulation function 1~99: Burn in power accumulation period of time in hour
---	---------	------	---

Description:

The burn in period of time (hour) and the accumulated power (watt-hour) data are all saved in EEPROM. If the unit supports "burn in mode", the unit has to start to accumulate output power every hour when it is operating in burn in mode (shall be load on inverter). However, for the unit that does not support "burn in mode", it will start to accumulate the output power every hour when it is operating in load on inverter mode. The unit will write the accumulated output power into EEPROM for ONCE when the burn in time reaches the setup time "burn in period of time". Once the accumulated output power has been written into EEPROM, don't write the data again until it is cleared by the set command "burn in period of time and clear burn in accumulated output power".

TC9

Data: (Computer->UPS)

Name	Type	Value	Comment
TBD	TBD	TBD	TBD

Description:

User defined ATS testing set command for certain special function.

History

1.0	09/23/1997	
1.1	11/14/1997	
1.2	12/30/1997	Add VSN(Voltage Sensitivity)
1.3	10/09/1998	Control Outlet Add Regular Format ID Add TEL, BRD commands
1.31	01/26/1999	SDR from 99999 to 65535
1.32	03/04/1999	Add STA---Inverter Bad
1.33	04/28/1999	Add ENV, Battery Level, Rating Battery Voltage Mark some items that UPS must support
1.34	05/03/1999	Change BUZ Status(0: Buzzer off, 1:Buzzer on)
1.35	07/21/1999	Economic Mode enable/disable Periodic Auto-test Buzzer Test ATX Reboot enable/disable Auto Reboot enable/disable
1.36	07/28/1999	Add RSM---Resume PC, AVL rearrange
1.37	08/17/1999	Change Length of MNU, MOD and VER to 16 Change Range of RNF from 1 to 65535
1.38	05/09/2000	Add the Emergency Power Off item in the STA
1.39	04/03/2001	Add TXF(Raymond), UBD Commands Define the ARB command
1.40	07/18/2001	Add SOV command
1.41	01/25/2002	Delete the RST command because it is conflict to the ARB command. Redefine BUZ command to alarm/silence Add EDB command to enable/disable buzzer alarm Define a standard string of Windows Plug & Play
1.42	01/30/2002	Redefine 'Battery Temperature' to 'Temperature'
1.43	03/29/2002	Add WDG Set command for watchdog
1.44	05/24/2002	Add BTV command for battery test
1.45	07/03/2002	Add WDG Get polling command
1.46	07/12/2004	Add Watchdog Alarm and EPO by TrippLite Mike
1.47	12/13/2004	Add CPU command
1.48	07/06/2005	Support Split Phase UPS
1.49	11/11/2005	Add Protocol ID 0x4002 for splite phase Add SER command for serial number
1.50	09/05/2006	Add External Battery Pack
1.51	10/30/2006	Improve to compatible with 3Phase protocol Append checksum option at the end of packet
1.52	12/24/2006	Add IDC
1.53	01/09/2007 01/25/2007	Add AL1,AL2,AL3 Add negative battery items in STB
1.54	05/23/2007	EBP append 'Battery Pack Model' item
1.54a	11/01/2007	Add CPU 4100 for NH series without checksum
1.54b	02/27/2008	Discuss internally on 1/30 and 2/27 Explain detail information for each command

		Delete WDG, SOV, RSM, ATX and TEL commands
1.55	03/05/2009	Add commands for HVDC UPS Add DWR for shutdown reasons
1.55a	05/08/2009	Modify STO for kW, kVA and Pf
1.55b	03/25/2010	Modify PIS: Add bit22 STS on/off Modify BCT: Add battery cabinet breaker field
1.55c	08/19/2010	Add Repair bit for PMS Add CHS for charger steps Add Auto Test Command for Production in Appendix F
1.55d	10/29/2010	Add DPS and DPH number in the MOD Series field
1.55e	02/16/2011	Add Output Breaker Alarm in the STA command
1.55f	10/11/2011	Add PIC, PMV, PMC commands (Slade)
1.55g	12/26/2011 12/29/2011	Add LOK command (Slade) Add Charging Current in STB Add Alarm Phase Asynchronous in STA Add Alarm Rectifier Abnormal in STA
1.55h	04/30/2012	Add Polling LOK command (Slade)
1.55i	06/18/2012	Modify Battery Charge item of STB command (Slade) Floating Charging → Charged Boost Charging → Charging Add battery fuse open in PFS command bit11
1.55j	08/01/2012	Modify Battery Charge item of STB command (Slade) Charged → obsolete
1.55k	08/27/2012	Add Battery Charge Mode in STB(James)
1.55m	12/07/2012	Add Battery low limit in STB (Dean) Add Set battery low limit in BLA command (Dean)
1.55n	09/04/2013	Modify PIS description : PFC Status -> Inverter Status(James) Add Inverter status-B21:Inverter Off In PIS (James) Add Bypass Breaker Open in STA(James) Add Main Input Breaker Open in STA(James)
1.55o	03/12/2014	Add EMS1000 temperature report command EMS Replace EMS option in AVL command b11(RST)
1.55p	12/04/2014	Add STO Output Source 8 for On ECO (Unco)