

# Connectivity

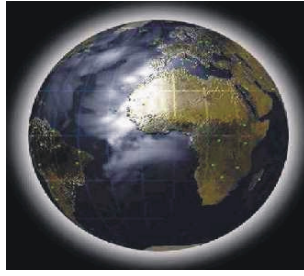

*the evolution*

## **Hirolink for Modbus V 3.00**

### **General Documentation**

**Service Manual**

**English**

Code 272401 21/11/07 Release 1.23E

**CONTENTS**

**1. INTRODUCTION..... 3**

**2. OVERVIEW ..... 3**

**3. SERIAL COMMUNICATIONS BASICS ..... 3**

3.1 THE BINARY FORMAT ..... 3

3.2 INTERFACE STANDARDS ..... 3

3.3 THE UART ..... 3

3.4 DATA-TRANSMISSION..... 3

**4. THE MODBUS-PROTOCOL ..... 3**

4.1 MODBUS-ADDRESSING..... 3

4.2 MODBUS-DATATYPES ..... 3

4.3 MODBUS-FUNCTIONS ..... 3

4.4 EXAMPLES ..... 3

**5. HIROMATIC-SPECIFIC TOPICS..... 3**

5.1 COMPATIBILITY ..... 3

5.2 NETWORKING SYSTEMS ..... 3

5.3 SENDING 'COMMANDS' ..... 3

5.4 THE STATUS-REPORT ..... 3

**6. INSTALLATION PROCEDURE ..... 3**

6.1 THINGS TO DO BEFORE INSTALLATION ..... 3

6.2 PREPARING THE HIROMATICS ..... 3

6.3 CONNECTING HIROMATIC G AND E TOGETHER ..... 3

6.4 PREPARING THE ICOM BOARD ..... 3

6.5 PREPARING THE HIROLINK..... 3

6.6 CONNECTING THE HIROLINK TO THE HIROMATICS, ICOM BOARDS..... 3

6.7 CONNECTING THE HIROLINK TO THE MODBUS-NETWORK ..... 3

**7. TESTING THE INSTALLATION ..... 3**

7.1 USING THE HIROLINK-LEDs ..... 3

7.2 APPLICATION 'MODBUS.EXE' ..... 3

7.3 SERVICE-INTERFACE..... 3

**8. HARDWARE-REFERENCE..... 3**

8.1 4-CONNECTOR HIROLINK ..... 3

8.2 HIROLINK-INTERFACE-CARD-SOCKETS ..... 3

8.3 HIROLINK-INTERFACE-CARDS (ONLY FOR THE 4-CONNECTOR HIROLINK) ..... 3

8.4 HIROMATIC-INTERFACE-CARDS ..... 3

8.5 CONNECTION BETWEEN HIROLINK AND HIROMATICS ..... 3

8.6 STANDARD PC-COM-PORT-PINNING ..... 3

## 1. Introduction

This document contains a general description of the 'Hirolink for Modbus'. Its purpose is to give you an overview of the functionality provided by this type of Hirolink.

It contains a short introduction to serial communications in general, a short description of the Modbus-protocol, detailed installation-instructions and a testing guide.

This document ***does not*** contain any specific information about a certain type of air-conditioner, but only information that applies to the Hirolink and the air-conditioners in general.

Detailed information about the data-points provided by each type of air-conditioner can be obtained from the relevant documents. These documents are called 'Hirolink for Modbus V X.XX - Items for YYY-Units V Z.ZZ', where 'X.XX' specifies the Hirolink-version, YYY specifies the air-conditioners software-type and Z.ZZ specifies the software-version of the air-conditioners software.

## 2. Overview

In general a Hirolink provides the means to connect Air-conditioners units to other devices, which use a different protocol than the air-conditioners themselves.

The term 'protocol' can be defined as the set of rules that a device has to respect when trying to communicate with another device. In other words a protocol defines the language which is used to speak to each other.

Basically the Hirolink is a protocol-converter or gateway, i.e. it is able to understand two different protocols and can make the translation from one to the other and vice versa.

The 'Hirolink for Modbus' in particular forms this gateway between the Air-conditioners units, which use the Hironet-protocol and other devices using the Modbus-protocol.

Although any device using the Modbus-protocol could communicate with a Air-conditioners units via the Hirolink, the typical case will be that a Building-Management-System (BMS) communicates with the air-conditioners to receive status- and alarm-information, as shown in the following illustration:

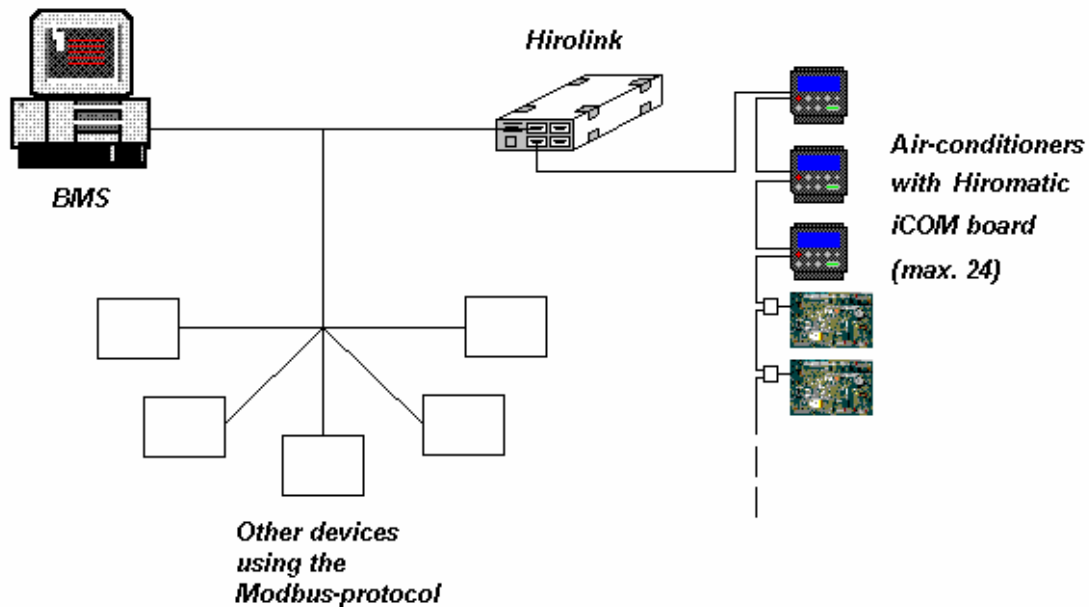

The air-conditioner unit, to be able to communicate with Hirolink, has to be equipped with a HIROMATIC-controller. Therefore the air-conditioners will be referred to as 'Hiromatics' for the remainder of the document. Be aware that a maximum of 24 air conditioners can be connected to one Hirolink.

The Modbus-protocol was defined by a company called 'MODICON Inc.', so at the start it was also a proprietary protocol. But since it is very flexible, easy to understand and also easy to implement more and more companies implemented it and so over the years it has become a industry-standard.

### 3. Serial Communications Basics

This chapter should give you a short introduction in the way how electronic devices communicate with each other. It is intended to give you a basic knowledge about this topic, but of course not all aspects of serial communications can be covered in here. Therefore this chapter is focused on those aspects that are relevant for using the Hirolink.

#### 3.1 The Binary Format

As you probably already know, computers work exclusively with numbers. These numbers represent the instructions and the parameters a program has to execute.

For example:

When a computer starts to execute a program, it knows that the first number it reads represents an instruction. Let's say it reads the number '130' (these numbers are also called 'code') and let's also say that this code is the instruction to perform an addition of two arguments. Out of this information, the computer knows that the next two codes it reads are the two arguments it should add. So it reads these two codes and performs the addition. The result of this addition is then stored internally and can be used for further instructions (Of course this is a very simplified way of explaining how a computer works).

To be able to execute a program, the computer has to read its instructions from some 'store-room'. This 'store-room' has to hold the instructions and has to be able to transmit it to the computer. The only efficient way to store these instructions was found to be the binary format.

Binary format means that each digit of a number has only 2 different states, '0' and '1'. This is only a different way of representing a number as for example in the decimal format, which is used in everyday live. In the decimal system each digit has 10 different states, '0' to '9'.

The following table shows how numbers in the decimal format are represented in the binary format:

Decimal format	Binary format
0	0
1	1
2	10
3	11
4	100
5	101
6	110
7	111
8	1000
9	1001
10	1010

Each digit of a binary number is called 'bit'. 'Bits' are usually numbered starting from 0, which means that the least significant (the most right in the table above) is usually called 'Bit 0', the next one 'Bit 1' and so on.

Since computers use the binary format internally, it is also their 'natural' way of communicating with each other. This means that if one computer wants to transmit information to another computer it is using only '0s' and '1s'.

### 3.2 Interface Standards

Electronic devices like the Hirolink usually communicate with other devices over a 'serial' line. 'Serial' means, that each bit of a number has to be transmitted one after the other. 'Parallel' on the other hand, means that each bit of a binary number is transmitted via its own line, enabling the devices to transmit a complete binary number at once. In this case you would need as many lines as the binary number has bits (e.g. 8). This kind of communication is often used between PCs and printers, but for obvious reasons (too many cables) usually not in building-management-systems.

To transmit information over a serial line, the device has to convert the bits into electrical signals. Since there are unlimited ways of how to represent a '1' or a '0' using electrical signals, devices that want to communicate with each other must use the same way of converting the bits into electrical signals and vice versa. This common way of conversion is called 'Interface Standard'.

On the level of digital controllers like the Hirolink usually one of the two following interface standards is used:

#### 3.2.1 EIA232 (RS232) Interface-Standard

This standard was called RS232 (Recommended Standard) at the time of definition, which was more than 30 years ago. Since then it has been modified several times and was also renamed to EIA232 (Electronic Industries Association), but the name RS232 is still commonly used.

This standard defines that a logical '0' is represented by a voltage between +3V and +15V and a logical '1' by a voltage between -15V and -3V, as shown in the following illustrations:

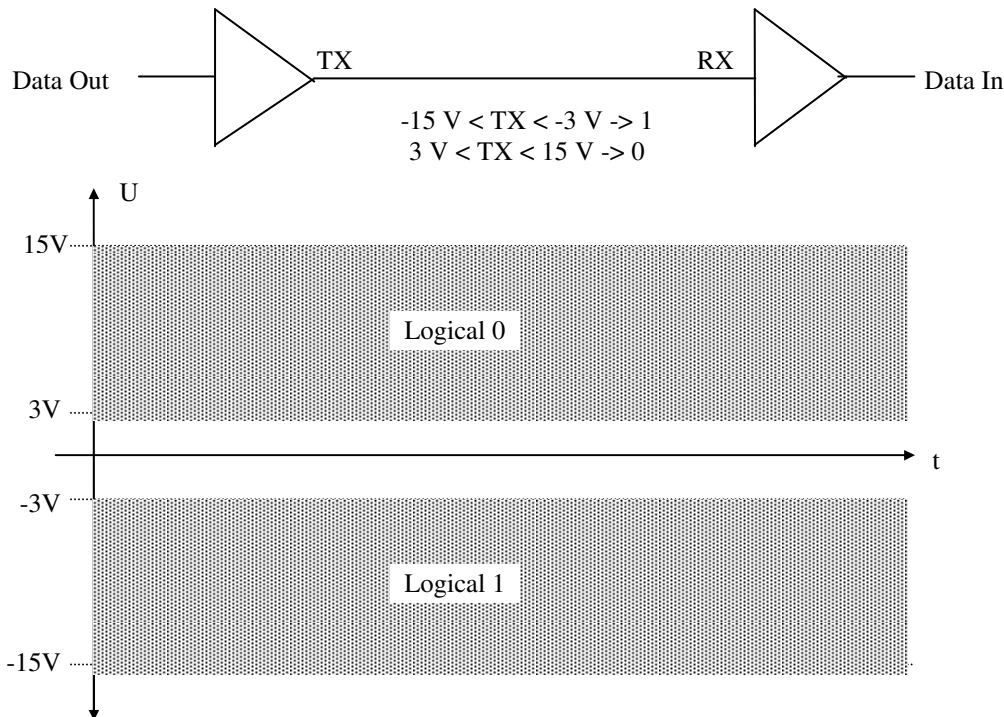

Maximum distance: 15 m  
 Maximum transmission speed: 20 kBit/sec

No multidrop-functionality has been defined in this standard, which means that only two devices can be connected with each other.

Usually you will find, that one device has both a transmitter and a receiver to enable a bi-directional communication:

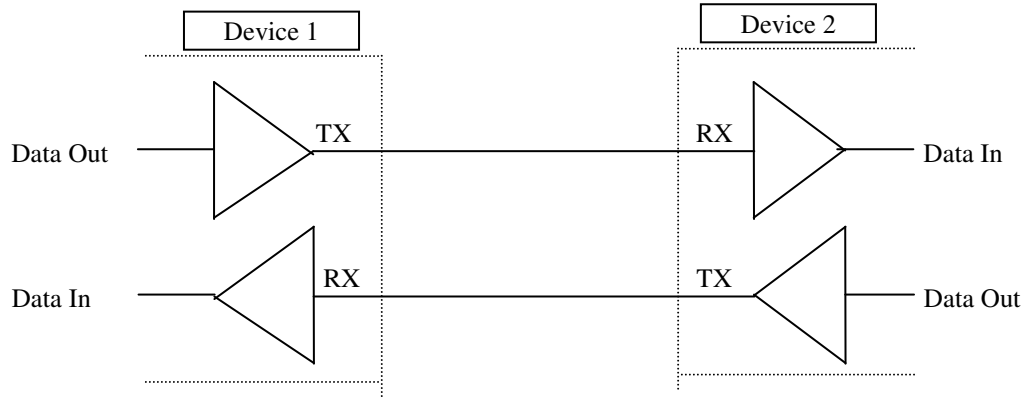

### 3.2.2 EIA485 (RS485) Interface-Standard

In the same way as for the EIA232-standard, also this one was called RS485 (Recommended Standard) at the time of definition and also has been renamed to EIA485 (Electronic Industries Association), but the name RS485 is still commonly used.

This standard uses a balanced (differential) transmission line in a multidrop configuration, meaning that instead of an absolute voltage on one line, it uses the difference between the voltages on two separated lines to represent '0s' and '1s' as shown in the following illustration:

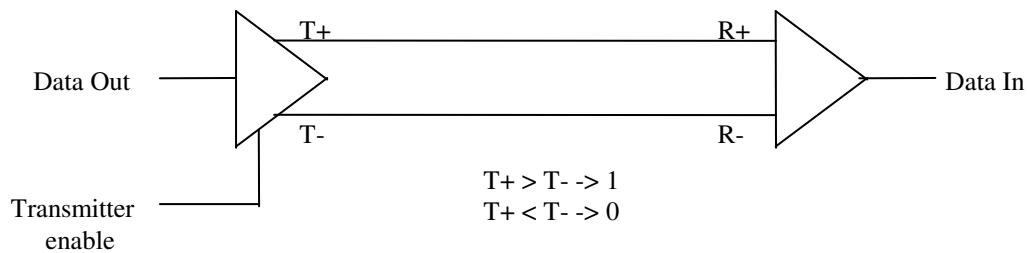

If the voltage on T+ is higher than the voltage on T- by at least 0,2 V, the receiver detects a '1'. On the other hand, if the voltage on T+ is lower than the voltage on T- by at least 0,2 V, the receiver detects a '0'.

This kind of transmission increases the immunity against noise on the line, since distortions are usually changing the signal voltage on both lines in the same direction. This doesn't affect the transmitted data on an EIA485 since the difference between the voltages is still the same. On the other hand, the signal could be changed from '1' to '0' or vice versa on an EIA232.

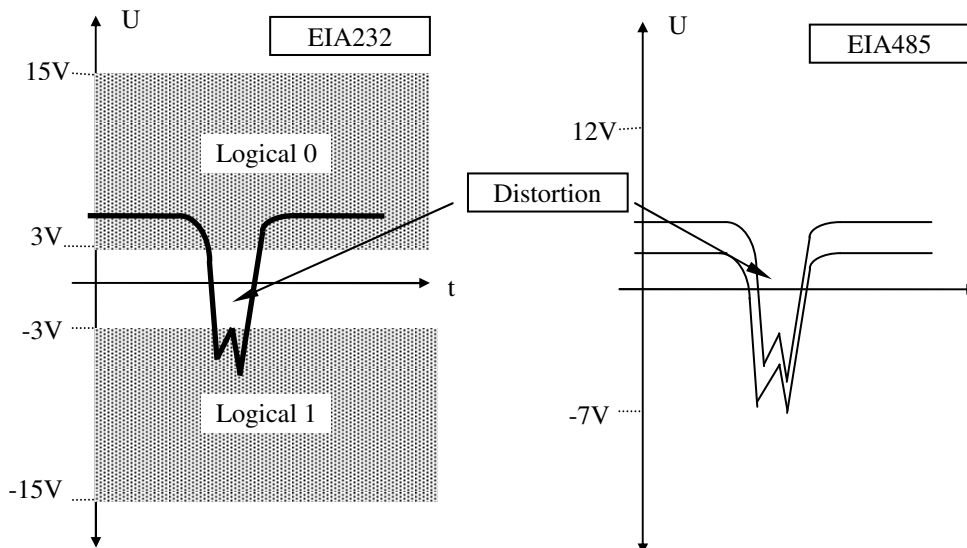

In this standard the maximum transmission speed is a function of the distance between transmitter and receiver:

Transmission speed	Cable length
10 Mbit/sec	12 m
100 kBit/sec	1200 m

The ability to switch off the transmitter enables this standard to be used in a multidrop configuration. This means that a maximum of 32 nodes (drivers and receivers) can be connected to one transmission-line. As with the EIA232-standard you will usually find both a transmitter and receiver in one device to enable a bi-directional communication as shown in the following illustration:

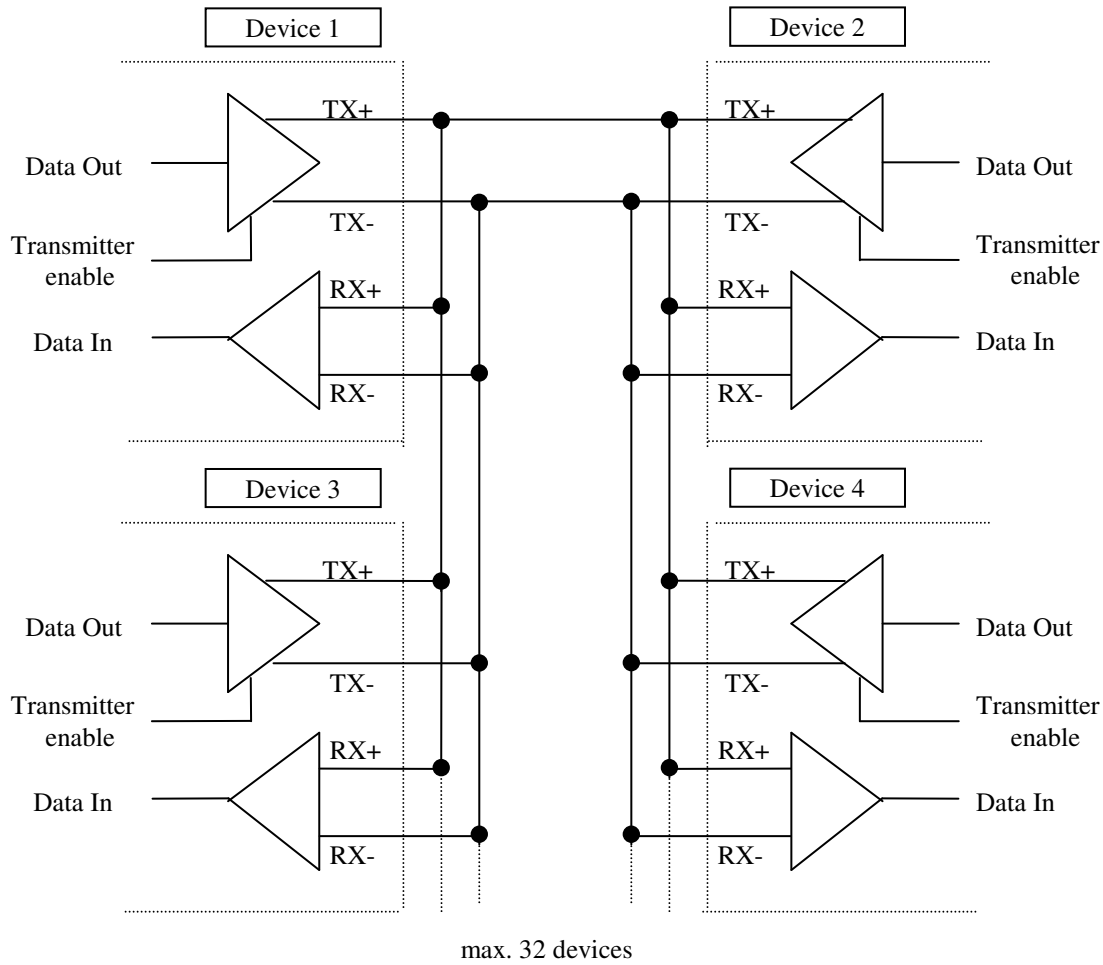



### 3.3 The UART

After having defined how a bit should be represented on a serial line, the next step to define is the way to transmit a binary number. In a similar way as standards have been defined to represent single bits on a serial line, also a standard to represent binary numbers has been found, although it is not a 'standard' in the usual sense. This means, that it hasn't been defined by some organization like the EIA or ISO and it hasn't been written down in an official paper, but a company has once started using this way of communication, others have copied it and over the years it has become a common way of communicating. When something like this happens, the resulting standard is usually called 'quasi standard' or 'industry standard'.

This has happened in computer communication with the so-called UART (Universal Asynchronous Receiver and Transmitter). A UART is a chip, which has been developed with the IBM-PC in the early 80's and enabled the IBM-PC to communicate with other PCs directly or via modems. It defined a way of transmitting and receiving binary numbers, which since then has become an industry standard.

The UART defines, that a sequence of bits has to be transmitted in the following way:

1. Start-Bit:  
Marks the start of a transmission. This bit is always logical '0'.
2. Data-Bits:  
A sequence of bits, which represents the transmitted data.
3. Parity-Bit (Optional):  
A parity-bit, which enables the receiver to check, if the transmitted data is correct. This bit is optional.
4. Stop-Bit(s):  
Marks the end of transmission. This bit is always logical '1'.

Some parameters (the so-called 'communication-parameters') have to be defined before two devices can communicate with each other. These 'communication-parameters' are the following:

- Baudrate:  
Defines the speed of communication. The baudrate is the number of bits, that are transmitted per second. For example 9600 Bd (Bd is the abbreviation for baudrate) means that each bit is put for 1/9600 s ( $\approx 104 \mu\text{s}$ ) on the line. Commonly used baudrates are 1200 Bd, 2400 Bd, 4800 Bd, 9600 Bd and 19200 Bd. Higher and lower baudrates are also possible, but rarely used on low-level controllers like the Hirolink.
- # of data-bits:  
Defines the number of data-bits in each transmission, which represent the 'real' information. This number can be set between 5 and 8, but usually only 7 or 8 bits are used. A sequence of 8 bits is usually referred to as 'Byte', so in most cases you will hear that bytes are transmitted (if only 7 bits are transmitted, the 8<sup>th</sup> bit is usually set to 0 by the receiver internally).
- Parity-bit:  
If enabled, this bit is appended to the data-bits and enables the receiver to check the validity of the received data-bits.  
Usually it is set to 'EVEN' or 'ODD'. 'EVEN' means, that the parity-bit has to be set in that way that the total number (data-bits + parity-bit) of '1s' in a transmission is even, while 'ODD' means the opposite.

Another possibility, which is rarely used, is to set the parity-bit to a fixed state. This means that the parity-bit has to be '1' or '0' in all transmissions. In this case it is called 'SPACE' (when setting the parity to '1') or 'MARK' (when setting the parity to '0').

The parity-bit is optional and can be left out. In this case it is called 'NONE'.

- Stop-Bits:  
This bit marks the end of transmission and can be set to different lengths (1, 1 ½ and 2 bits).

The following illustration shows how a typical transmission would look like on the line:

Transmission with 8-bit data-length, parity-bit and 1 stop-bit. The length of each of these bits is defined by the baudrate. For example with a baudrate of 9600 Bd each bit-length would be approximately 104  $\mu$ s.

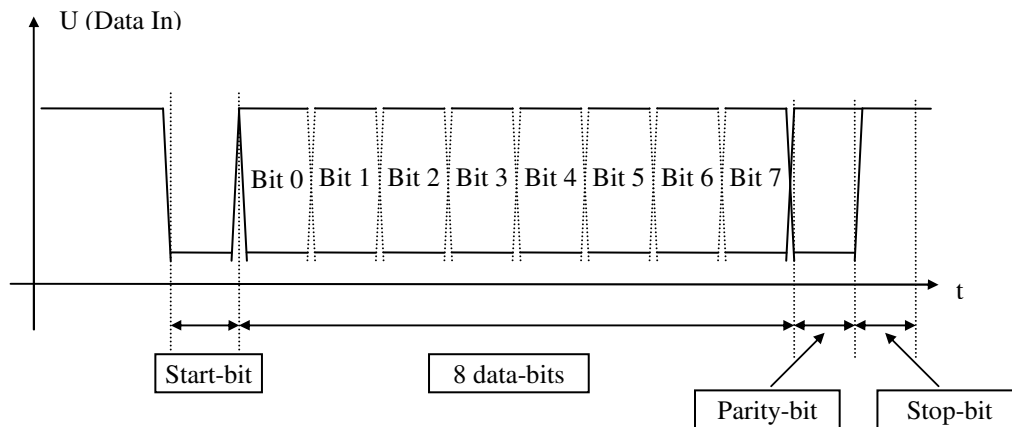

### 3.4 Data-Transmission

Having defined the way to transmit single bits and bytes, we are still quite a distance from having established a conversation between two devices.

Until now the two (or more) devices are only able to exchange bytes of information. So they are able to send or receive a stream of bytes, but they don't know how to use the information they receive. This means that a set of rules has to be defined, which has to be respected by all devices that want to communicate with each other.

This set of rules is called 'Protocol' and defines how the information must be structured within a transmission. For example it defines how a transmission is started and ended (also called the 'Message Frame'), where the device-address can be found, where instructions are transmitted and many more.

The 'Protocol' that is implemented in this Hirolink, is described in the next chapter.

## 4. The Modbus-Protocol

This chapter contains a short description of the main-features of the Modbus-protocol, to provide a better understanding of the integration of Hiromatics into a Modbus-network. It only contains the basic principles, so if you would like to know more details, please check out to following document:

Modicon  
Modbus Protocol Reference Guide  
PI-MBUS-300 Rev. D

Issued in March 1992 by

MODICON, Inc., Industrial Automation Systems  
One High Street  
North Andover, Massachusetts 01845

The Modbus-protocol works on a Master-Slave-basis. This means that there is only one device on the Modbus-network, which is allowed to send requests to other devices. This device is called 'Master'.

All other devices on the network only respond to requests received from the master and will never initiate a transmission by themselves. These devices are called 'Slaves'.

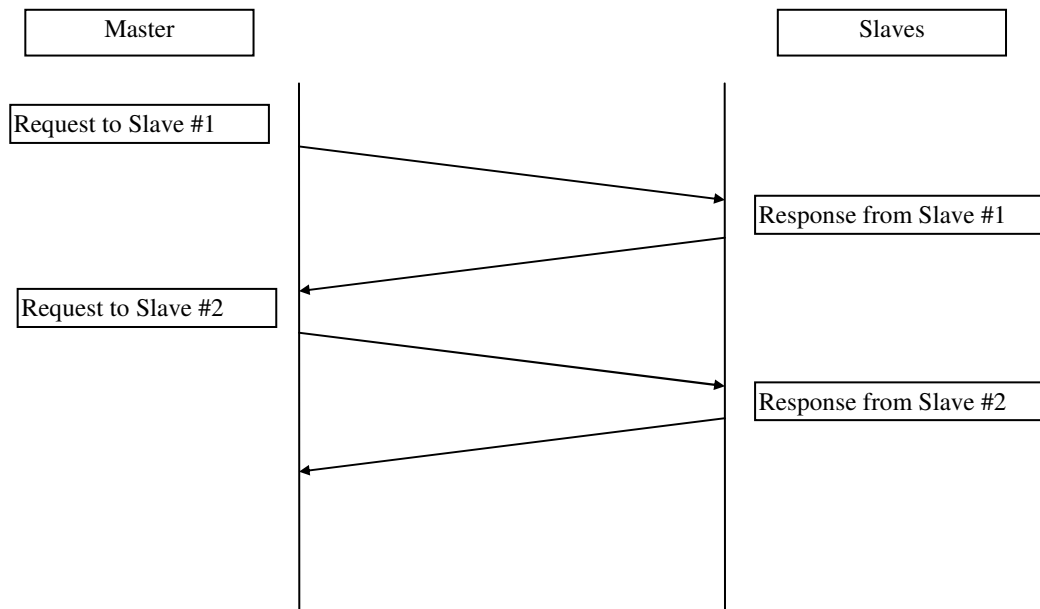

The slave who should respond to a request is identified by an address, which is described in the next chapter.

## 4.1 Modbus-Addressing

As mentioned in the chapter above the master is sending requests to its slaves and is waiting for their answer. To identify the slave that should respond, the request contains an 'Address'.

Therefore each slave on the Modbus-network must have an address and this address must be unique in the whole network.

The master needs no address, because this device is the only one that issues requests, so any response coming from the slaves automatically has to be the answer to a request sent by the master.

In the Modbus-protocol one byte (a byte is a 8-bit numerical value, which can hold values from 0 - 255) of each request is reserved for the address. The protocol defines that valid addresses have to use a range between 0 and 247, where address 0 is used for broadcasts. Broadcasts are transmissions that are meant to be received by all slaves at the same time.

Therefore 0 is not a valid address for a slave and only the addresses 1 to 247 can be used as slave-addresses.

## 4.2 Modbus-Datatypes

The Modbus-protocol defines 4 types of data, which can be accessed via the Modbus-protocol using different Modbus-functions. These types are:

- Coil:  
Digital value, which can be read and written to.
- Input:  
Digital value, which can only be read.
- Holding Register:  
Analog value, which can be read and written to. In general a 'Holding Register' is a 16-bit value. Usually these values are in integer format, although when interfacing to Hiromatics some values have to be interpreted as unsigned integers (also called 'word').
- Input Register:  
Analog value, which can only be read. In general a 'Input Register' is a 16-bit value. Usually these values are in integer format, although when interfacing to Hiromatics some values have to be interpreted as unsigned integers (also called 'word').

The Modbus-protocol defines that each of these types can be addressed using a 16-bit value. This means, that each slave on the Modbus-network can hold a maximum of 65535 values of each type, i.e. 65535 coils, 65535 inputs and so on.

On the other hand this doesn't mean that each slave **must** hold this number of values, but it is up to the slave how many values of each type are defined and available.

The Modbus-functions, which are used to access these values, are described in the next chapter.

### 4.3 Modbus-Functions

When a slave receives a request from the master, it needs to know what kind of request it is, so that it can decide what to do with the received information.

Similar to the address described above, the request also contains a so-called 'Function'. By evaluating this 'Function', the slave can find out how the rest of the request is built up and how to interpret the request, i.e. by checking the 'Function' the slave can find out exactly what the master expects him to do. Therefore 'Modbus-Functions' are requests of a specific type.

In the Modbus-protocol one byte (a byte is a numerical value, which can hold values from 0 - 255) of each request is reserved for the 'Function'. Certain values are pre-defined and have to be used for specific uses, while others can be used to implement additional functionality.

The following lists the Modbus-functions that are supported by the Hirolink:

Function	Modbus-Denotation	Comment
01	Read Coil Status	Used to read digital outputs
02	Read Input Status	Used to read digital inputs
03	Read Holding Register	Used to read analog outputs
04	Read Input Register	Used to read analog inputs
05	Force Single Coil	Used to set a digital output
06	Preset Single Register	Used to set a analog output
16	Preset Multiple Registers	Use to set multiple analog outputs; <b>IMPLEMENTED FOR SINGLE PRESET ONLY.</b>
08-00	Return Query Data	Diagnostic-function: The received request is returned unchanged
08-01	Restart Communications Option	Diagnostic-function: Restart the communication after 'Force Listen Only Mode'
08-04	Force Listen Only Mode	Diagnostic-function: Tells the Hirolink <i><b>not</b></i> to answer to any request until 'Restart Communications Option' is received

## 4.4 Examples

NOTE:

The examples in the following sections have informational character only. The byte-lengths of the single fields in each transmission are only valid for the so-called 'RTU'-transmission-mode. For more detailed information please check out the complete Modbus-protocol-specification mentioned at the beginning of this chapter.

### 4.4.1 Reading of 'Holding Registers' or 'Input Registers'

Request:

Slave ID	Function code	Address of 1 <sup>st</sup> register	Number of registers	Check-sum
1 byte	1 byte	2 bytes	2 bytes	2 byte

Response:

Slave ID	Function code	Number of bytes	Value of 1 <sup>st</sup> register	Value of last register	Check-sum
1 byte	1 byte	1 byte	2 bytes	2 bytes	2 byte

If a value consists of 2 bytes (words or integers) the high byte is always sent first.

Slave-ID:

This byte defines which slave should respond to the request. It has the same value in the request and the response.

Function-code:

This byte defines which function should be performed by the slave. In the case of reading 'Holding Registers' this value would be 3 and in the case of reading 'Input Registers' 4. It has the same value in the request and the response.

Address of 1<sup>st</sup> register:

This word defines the first register to be read. Numbering of registers starts with 0 in the request, although in general registers are numbered starting with 1. So for reading Holding Register #1 you would have to send 0 for the address of the register.

Number of registers:

This word defines how many register-values should be returned by the slave.

Number of bytes:

This value defines how many bytes are to follow, excluding the checksum.

Values of registers:

These integers hold the values of the registers that have been requested.

#### 4.4.2 Reading of 'Coils' or 'Input Status'

Request:

Slave ID	Function code	Address of 1 <sup>st</sup> register	Number of registers	Check-sum
1 byte	1 byte	2 bytes	2 bytes	2 byte

Response:

Slave ID	Function code	Number of bytes	Register-value(s)	Register-value(s)	Check-sum
1 byte	1 byte	1 byte	1 byte	1 bytes	2 byte

If a value consists of 2 bytes (words or integers) the high byte is always sent first.

**Slave-ID:**

This byte defines which slave should respond to the request. It has the same value in the request and the response.

**Function-code:**

This byte defines which function should be performed by the slave. In the case of reading 'Coils' this value would be 1 and in the case of reading 'Input Status' 2. It has the same value in the request and the response.

**Address of 1<sup>st</sup> register:**

This word defines the first register to be read. Numbering of registers starts with 0 in the request, although in general registers are numbered starting with 1. So for reading Coil #1 you would have to send 0 for the address of the register.

**Number of registers:**

This word defines how many register-values should be returned by the slave.

**Number of bytes:**

This value defines how many bytes are to follow, excluding the checksum.

**Values of registers:**

These bytes hold the values of the registers that have been requested, where each bit represents one register-value. This means that bit 0 of the first returned byte holds the value of the first requested register, bit 1 of the second register and so on.

### 4.4.3 Writing of a 'Holding Register' or a 'Coil'

Request:

Slave ID	Function code	Address of register	Value of register	Check-sum
1 byte	1 byte	2 bytes	2 bytes	2 byte

Response:

Slave ID	Function code	Address of register	Value of register	Check-sum
1 byte	1 byte	2 bytes	2 bytes	2 byte

If a value consists of 2 bytes (words or integers) the high byte is always sent first.

**Slave-ID:**

This byte defines which slave should respond to the request. It has the same value in the request and the response.

**Function-code:**

This byte defines which function should be performed by the slave. In the case of writing a 'Holding Register' this value would be 6 and in the case of writing a 'Coil' 5. It has the same value in the request and the response.

**Address of register:**

This word defines the register to be written. Numbering of registers starts with 0 in the request, although in general registers are numbered starting with 1. So for writing Holding Register #1 you would have to send 0 for the address of the register. It has the same value in the request and the response.

**Value of register:**

This word defines the value that should be written to the register. In the case of 'Coils' the value is '0000' when setting it to 'OFF' and 'FF00' when setting it to 'ON'. It has the same value in the request and the response.



#### 4.4.4 Error-Response

In all the examples mentioned above, there is the possibility of an error-response, when an attempt was made to read or write a register that is not defined in the slave.

In this case the slave will set the most significant bit (bit 7) of the received function-code and will return only the slave-id and the function-code as shown in the following illustration:

Error-Response:

Slave ID	Function code	Error-code	Check-sum
1 byte	1 byte	1 byte	2 byte

## 5. Hiromatic-Specific Topics

This chapter contains topics that must be respected when integrating Hiromatics into a Modbus-network.

### 5.1 *Compatibility*

Enforced by the characteristics of the Hironet-protocol, the Hirolink has to hold a table, which describes the way how to communicate with a given type of Hiromatic and also which data-points have to be mapped to which registers on the Modbus-side of the network.

Therefore the Hirolink is NOT compatible with all types of Hiromatics and also NOT with all versions of a given type, since also the amount of available data-points can change from one version of a Hiromatic-type to the next.

For this reason a compatibility-list is provided in appendix Appendix B: of this document and also in the documents containing the available data-points for each Hiromatic-type. Those documents are called 'Hirolink for Modbus V X.XX - Items for YYY-Units V Z.ZZ, where X.XX stands for the Hirolink-software-version, YYY for the Hiromatic-type and Z.ZZ for the software-version of this Hiromatic-type.

So make sure that the Hiromatics you want to integrate into the Modbus-network are compatible with this version of the Hirolink.

## 5.2 Networking Systems

In general there are 3 types of controllers that can be used in an air-conditioner equipped with a Hiromatic E and one without Hiromatic E:

- **Module:**  
This is the simplest form of controller, which only consists of expansion boards that are plugged into the back of the Hiromatic. These 'Modules' provide the I/Os for controlling the components and 'upgrade' the Hiromatic to perform also the regulation-functions.
- **Macroface:**  
This kind of controller is connected to the Hiromatic via the so-called 'Hirobus' through which they communicate. Depending on the Hiromatic-type a Macroface either works alone or can be connected with other Macrofaces to form a system. The maximum number of Macrofaces that can work with each other depends on the Hiromatic-type.
- **Microface:**  
This kind of controller is a smaller version of the 'Macroface' and is also connected to the Hiromatic via the 'Hirobus'. All Hiromatic-types using a Microface can be connected with other Microfaces to form a system. The maximum number of Microfaces that can work with each other is 16, **but when the Hiromatic is connected to a Hirolink the maximum number is 8.**
- **iCOM control (Large-Medium)**  
This kind of controller is new control generation for HPAC units and chiller produced for Emerson Network Power units. The Hirolink for Modbus is in condition to support up to 24 controls.

See appendix 'Hiromatic-Types' for a complete list of Hiromatic-types, controller-types and the maximum number of connectable controllers.

As described above some Hiromatic-types are operating in a networking-mode. This means that a variable number of air-conditioners can be connected with each other to form a system. Note that mixed installations are not possible, i.e. you can not mix 'Macrofaces' and 'Microfaces'. **You can mix Microface E and iCOM controls but connect all of them to Hirolink for BMS via Hiromatic E.**

Within a networking-system data is exchanged, which informs the single controllers about certain alarm-conditions, average temperatures, system-wide set-points and so on.

To enable the communication with the Hirolink, one Hiromatic has to be connected, which transfers the data from the single controllers and its own to the Hirolink. A address has to be assigned to the Hiromatic, under which it is accessible from the Hirolink and as a consequence from the Modbus-network.

Therefore all values and parameters from the complete system the Hiromatic or iCOM is connected to, are mapped into the Coils, Inputs, Holding Registers and Input Registers of one single slave as if those values would come from one single device.

For a better understanding, see the illustration below:

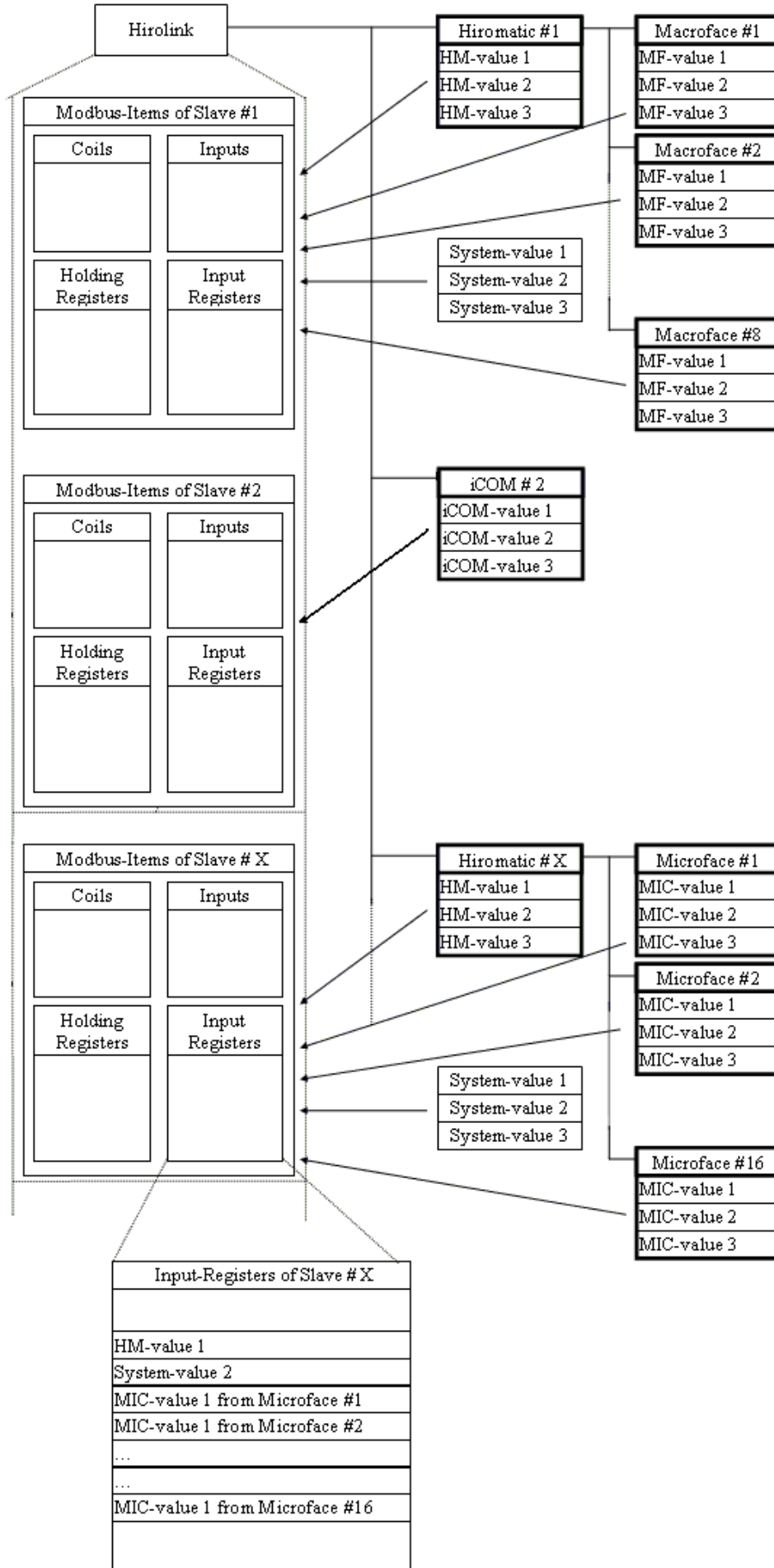

As the illustration shows, there are 3 different types of values that are received from the Hiromatic and made accessible to the Modbus-network:

- **HM-Values:**  
These values are only existing in the Hiromatic and therefore only exist once in the system (e.g. Time and Date).
- **System-Values:**  
These values are maintained by a Macroface or a Microface or iCOM, but are valid for the whole system (e.g. Shared Temperature, System Status). Therefore they also only exist once.
- **MF-Values, CTRL-Values:**  
These values are existing in each Macroface or Microface or iCOM and therefore the same value exists as often as the maximum number of connectable controllers defines.

In the list of available data-points (also called 'Item-Lists' in this document) accessible to the Modbus-network, those values are simply repeated as many times as controllers can be connected. These values are marked with the text 'MF 1 - X' or 'CTRL 1 - X' in the item-lists of the Hiromatic-type, where 'X' stands for the maximum number of connectable controllers).

**NOTE:**

The item-lists don't change, if less than the maximum number of controllers are connected. This means that in any case the controller-values are repeated as many times as controllers can be connected, but if less controllers are connected, the values provided for those controllers that are not connected are not valid.

**5.3 Sending 'Commands'**

In the item-lists provided for each Hiromatic-type, you will find 'Coils' marked with the appendix 'Command'. These items perform functions like switching the air-conditioner on or off and have to be treated in a special way:

These items must only be set to their 'On-State' once and must either not be written again or must at least be set back to their 'Off-State'. In other words, these commands should be treated like 'One shots' or like a push-button as shown in the following illustration:

For example: Coil activating 'System On'

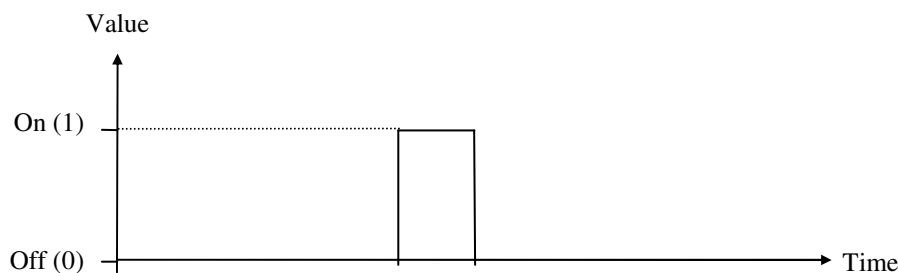

It is very important that these items are not permanently set to their 'On-State', also not in intervals of e.g. 1 minute.

Furthermore those items don't provide valid information when read. They will always return 'Off' when read, except for the first read after they have been set to 'On'. This is done in order to confirm the successful writing to the BMS.

The reason for this special treatment is actually only the coil activating the 'System On'-command, but it should be adopted as a general rule for all commands (since it for example doesn't make much sense to permanently set the 'Alarm Reset'-command).

When performing the 'System On'-command, the Hiromatic and the Macrofaces or Microfaces perform some initialization-routines, which for example completely close the chilled-water valves or reset a timer that prevents the regulation to activate any component for the next 2 minutes and other things. Each time the unit receives the 'System On'-command this initialization-routines are repeated. Therefore the regulation would never start to do its job, if the 'System On'-command is sent permanently or also in some interval.

The behavior described above doesn't apply to all Hiromatic-types, but to avoid problems this treatment should be adopted as a general rule for all coils marked with 'Command'.

### 5.4 The Status-Report

Each Hiromatic stores a certain amount of messages in a so called 'Status Report'. The 'Status-Report' records events like alarm-message or system-status-changes and can be compared with a log-file.

Depending on the Hiromatic-type the status-report has a variable size and the information contained has a different depth. For example Hiromatics with a LCD-dot-matrix display provide time and date information for each status-report entry, while Hiromatics with a custom LCD-display don't. Furthermore Hiromatic-types that run in a networking-system provide a controller-ID for each entry, which identifies the controller which generated the entry.

The status-report is handled as a ring-buffer, which means that the oldest entry will be discarded, if the maximum size is reached.

The following list gives an overview about the size of the status-report (maximum number of entries) and the depth of information each Hiromatic-type provides:

<b><i>Hiromatic-Type</i></b>	<b><i>Status-Report-Size</i></b>	<b><i>Time/Date provided</i></b>	<b><i>Controller-ID provided</i></b>
<b>CAM</b>	120	YES	YES
<b>Compact Custom</b>	20	NO	NO
<b>Dryer</b>	17	NO	NO
<b>Energy Partner</b>	120	YES	YES
<b>Energy Partner Small</b>	120	YES	YES
<b>CPU Chiller</b>	120	YES	YES
<b>Advanced Graphic</b>	60	YES	NO
<b>Compact Graphic</b>	60	YES	NO
<b>Hiflex</b>	200	YES	YES
<b>Hiwall</b>	200	YES	YES
<b>OENB</b>	200	YES	YES
<b>Superchiller/Hichill</b>	120	YES	YES
<b>SIP</b>	20	NO	NO
<b>Telecool Compact</b>	120	YES	YES
<b>Chiller</b>	200	YES	YES
<b>Superchiller</b>	200	YES	YES
<b>2000/Matrix</b>			

The Hirolink provides the possibility to read this status-report via the Modbus-network. For this purpose a block of Input Registers and one Holding Register is used.

Each Hiromatic-type defines the Input Registers #1 to #6 as the 'Status-Report-Block' and Holding Register #1 as the 'Status-Report-Acknowledge'.

The 'Status-Report-Block' is built up in the following way:

Input-Register #	Usage	Description
1	Event-ID	ID identifying the event
2	Controller-ID	Controller-ID, where the event occurred
3	Minute	Minute, when event occurred
4	Hour	Hour, when event occurred
5	Date	Date, when event occurred
6	Event-Type	0 -> message, 1 -> alarm 2 -> warning, 3 and 4 -> reset

If a Hiromatic-Type doesn't provide the controller-ID or the time and date of the event, the Hirolink will set these registers to 0.

After switching on the Hirolink, it starts scanning the Hironet for Hiromatics that might be connected. When finding a Hiromatic, the Hirolink copies the Hiromatics status-report into its own memory. As a sign that a new Hiromatic has been found on the Hironet, the Hirolink will set the 'Event-ID' of the 'Status-Report-Block' to the predefined value '100', which stands for 'UNIT CONNETCED'.

After that the Hirolink waits for the 'Status-Report-Acknowledge', which should be performed by the Modbus-master. The Modbus-master can issue this acknowledge by setting the Holding Register #1 to any value different from 0. Some older Hiromatic-types also define one coil (usually the last one) as the 'Status-Report-Acknowledge'. In this case both registers can be used alternatively, which means that there is no difference between setting the 'Status-Report-Acknowledge'-coil to 'On' or setting the 'Status-Report-Acknowledge'-Holding-Register to a value different from 0.

The 'Status-Report-Acknowledge'-register behaves like a 'Command'-register described in chapter 5.3 'Sending 'Commands'' in the sense that it always will be 0 when read except for the first read-request after it has been written to. The first read-request after it has been written to will return the value that was written. The difference to the other 'Command'-registers is, that it has no bad effect whatsoever, if you set this register to 1 permanently or in a certain interval.

### **IMPORTANT:**

Starting with 'Hirolink for Modbus V 2.80' the Hirolink can handle the 'Status-Report-Acknowledge' in two different ways selectable by a jumper (see chapter '0 Preparing the Hirolink'):

**When the jumper is not set**, the Hirolink behaves in the same way as 'Hirolink for Modbus'-versions prior to V 2.80. In this case the Hirolink regards the 'Status-Report-Acknowledge' as mandatory.

**Without having received this acknowledge the Hirolink will not update the data from Hironet device.** Therefore it is mandatory that the 'Status-Report-Acknowledge' is sent at least once after the Hirolink has connected to Hironet device. Also if the Hirolink loses the connection to one Hiromatic for some time and then finds it again, the acknowledge has to be sent again. **For some applications (microface/Hiromatic/iCOM) the summary of events is listed into a table of items from 5000. In this case it is not upgraded.**

The reason why this behavior was implemented in this way was that with previous Hiromatic-versions the Hirolink could prevent the 'Status Report' from overflowing when it didn't acknowledge the data received from the Hiromatic. Since this is not possible anymore a second way of handling the 'Status-Report-Acknowledge' has been implemented:

**When the jumper is set**, Hirolink does not regard the 'Status-Report-Acknowledge' as mandatory. In this case the Hirolink will update the data from the Hiromatic also without having received the 'Status-Report-Acknowledge'. In this case the Hirolink will transmit the event 'UNIT CONNECTED' until the first 'real' event is received from the Hiromatic only. As soon as this first 'real' event is received, the Hirolink will set the 'Status Report Block' according to the received data. **For some applications (microface/Hiromatic/iCOM) the summary of events is listed into a table of items from 5000. In this case it is not upgraded.**

In any case it's the Modbus-master's responsibility to read the 'Status-Report-Block' before overflowing when it is interested in this data. The Hirolink provides a buffer of the same size as the Hiromatic itself (see table above). This means that the Hirolink's buffer will overflow as soon as the Hiromatic reports

the n+1 alarm (where n stands for the Status Report size) and the Hirolink hasn't received a 'Status-Report-Acknowledge' until then. 'Overflowing' means that the Hirolink will overwrite the first reported alarm with the currently received one, which causes this information to be lost.

After having received the first acknowledge the Hirolink will fill the 'Status-Report-Block' with the oldest status-report-entry it has received from the Hiromatic. With each 'Status-Report-Acknowledge' it will fill the 'Status-Report-Block' with the next status-report-entry until all entries have been acknowledged. When no more status-report-entries are available, the Hirolink will set the complete 'Status-Report-Block' to 0. This is a sign for the Modbus-master that no more entries are available.

**NOTE:**

The only way for the Modbus-master to check, if more status-report-entries are available, is to check the 'Event-ID'- AND the 'Date'-Register for 0. Only if both register are 0, the Modbus-master can be sure that all status-report-entries have been read.

As soon as a new event occurs at the Hiromatic and an entry is made into the status-report, this entry will be reflected in the 'Status-Report-Block' and all registers will be set to 0 again, after the next acknowledge has been received by the Hirolink.

Should the Hirolink lose the connection to the Hiromatic for some reason, it will set the 'Event-ID' of the 'Status-Report-Block' to the predefined value '101', which stands for 'UNIT DISCONNECTED'.

**IMPORTANT:**

If the 'Status-Report-Acknowledge'-jumper (see chapter '0 Preparing the Hirolink') is not set, the Hirolink will continue to respond to requests for a Hiromatic to which it already has lost the connection. It will do this until the Modbus-master has issued a 'Status-Report-Acknowledge' for the 'UNIT DISCONNECTED'-event. Only after this has happened the Hirolink will stop responding to requests for this Hiromatic.

On the other hand when the 'Status-Report-Acknowledge'-jumper is set, the Hirolink immediately stops responding to requests for a Hiromatic as soon as it has lost the connection. Thus, the Modbus master will receive no 'UNIT DISCONNECTED'-event.

**NOTE:**

If the information the status-report provides is not needed in your installation, you can implement a loop, which issues a 'Status-Report-Acknowledge' in a regular interval without checking the 'Status-Report-Block'. Remember that the 'Status-Report-Acknowledge' is mandatory and **MUST** be issued, if the 'Status-Report-Acknowledge'-jumper **is not set**. The Hirolink is not affected in any way, if acknowledges are received when no more entries are available or if the Hiromatic is not connected at all. **Moreover the summary of events is listed into a table of items from 5000 is not upgraded.**

The following flow-diagram gives an example of how a program that requests the status-report in the Modbus-master could look like:

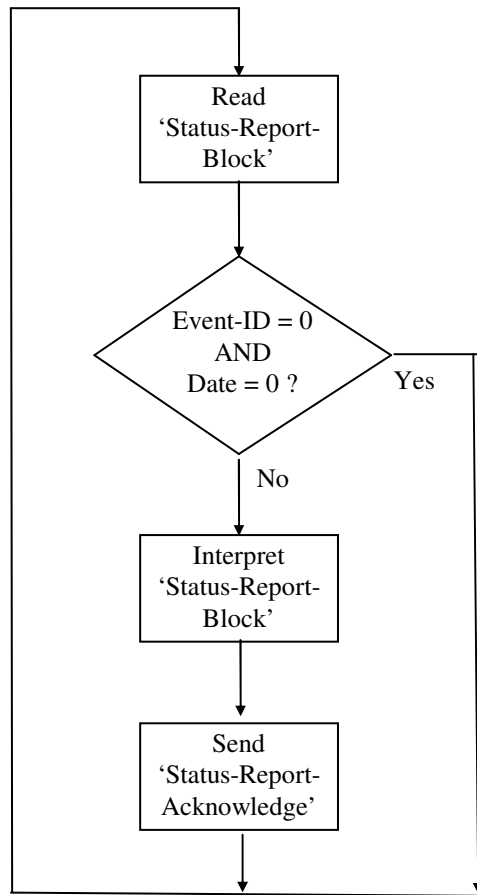

#### 5.4.1 Calculating the date of an event

The date of an event is transmitted in a compressed format, which can be uncompressed as follows:

'Date' is transmitted as:  $\text{'Date'} = \text{'Year'} * 512 + \text{'Month'} * 32 + \text{'Day'}$

To recalculate 'Year', 'Month' and 'Day' from 'Date' perform the following steps (all divisions are integer divisions):

$\text{'Year'} = \text{'Date'} / 512$   
 $\text{'Date'} = \text{'Date'} - \text{'Year'} * 512$   
 $\text{'Month'} = \text{'Date'} / 32$   
 $\text{'Date'} = \text{'Date'} - \text{'Month'} * 32$   
 $\text{'Day'} = \text{'Date'}$



## 6. Installation Procedure

This chapter contains step-by-step instructions on how to prepare and connect the Hiromatics-iCOM Board, and prepare the Hirolink, how to connect the Hiromatics-iCOM Board and how to connect the Modbus-network.

### 6.1 Things to do before installation

Before you even order the Hirolink, you should run through the following check-list and be able to answer all questions listed there to make sure that no bad surprises happen, when you want to put the Hirolink into operation:

- How many Hiromatics-iCOM Board will be connected to the Hirolink ?

Be sure that no more than 24 Air conditioners will be connected to one Hirolink. If the number of Hiromatics in your installation exceeds this number, you have to use a second or more Hirolinks.

- What's the location of the Hiromatics-iCOM Board?

Be sure that the total length of the cable connecting the Hiromatics-iCOM Board with the Hirolink doesn't exceed 1000 m. Also in this case you will need another Hirolink, if the needed cable-length exceeds this number.

- Are the software-versions used in the Hiromatics-iCOM Board supported by the Hirolink ?

A compatibility-list is provided in appendix Appendix B: in this document, which lists all Hiromatic-iCOM Board -software-versions that are currently supported by the Hirolink.

Compare this list with the software-versions used in your installation, to make sure that the Hirolink is able to communicate with all Hiromatics-iCOM Board you want to connect.

- Plan your installation

Draw a map of your installation, which shows the location of all Hiromatics-iCOM Board you want to connect.

Assign identification-numbers to all Hiromatics-iCOM Board you want to connect to the Hirolink(s). Each Hiromatics-iCOM Board must receive a identification-number, which is unique within the network of Hiromatics-iCOM Board that is connected to one single Hirolink. This means that you can use each identification-numbers between 1 and 99 once for each Hirolink in your installation.

## 6.2 Preparing the Hiromatics

- Note: there are 2 different types of Hiromatic available:
  - **Hiromatic G**and
  - **Hiromatic E (Evolution)**.The following steps will describe the actions to be done for both types.

To prepare the Hiromatics for a connection to the Hirolink, carry out the following steps:

### Step 1: Write down the software-information (Hiromatic G and Hiromatic E)

After switching on the Hiromatic, it will show the software-type, version and date for a few seconds. This information varies depending on the software-type, but in general you will see something like the following:

**HIROMATIC COMPACT  
DIRECT EXP.  
2.62 25.11.1996**

or

**WXG 1.60.026  
Mar 06 2003**

Note this information and keep it for later use.

### Step 2: Check the Hironet-settings (Hiromatic G and Hiromatic E)

The location of the Hironet-settings varies depending on the software-type, but in general they can be found on the second page of the 'SYSTEM SETUP'-menu.

These settings define the Identification-number and the baudrate and in some cases also the protocol and the communication-mode. Each of these settings is described in the following:

#### **Identification-number:**

The identification-number set on the Hiromatic defines the Modbus-Slave-ID, which has to be used to request data from the Hiromatic. As mentioned in the description of the protocol, this Slave-ID must be unique. Therefore it is very important that each Hiromatic receives a different identification-number.

After setting the identification-number, note it together with the software-information described in step 1. It is good advise to also note the position of the Hiromatic within the building.

#### **Baudrate:**

The baudrate defines the communication-speed, with which the Hiromatic communicates with the Hirolink and MUST be set to 20833 Baud for Hirolink for Modbus software version lower than 2.81. (Hiromatic E cannot work with versions lower than V 2.81).

In systems having Hirolink for Modbus versions equal or higher V 2.81, the Baudrate selected is not of importance, it could be even mixed up between several Hiromatics.

It is important to know that all software-types are prepared for use with 2 types of crystals (12 MHz and 11,0592 MHz). Depending on the used crystal the Hiromatic **G** will display different baudrates, since the baudrate also changes in reality.

The difficulty regarding this matter is, that not all software-types display the baudrate in the same way. Most software-types will show '20833 Bd', but some show '19.2 k'. Please check the list at the end of this section for information on which value is displayed for each crystal-type.

If you try to set the baudrate and the value for the 11,0592 MHz-crystal is displayed, there are 2 possibilities:

1. You have a Hiromatic **G** of hardware-version 3.5, which is equipped with both crystals and a jumper for selection. The following illustration shows the position of this jumper:

Hiromatic **G** Back

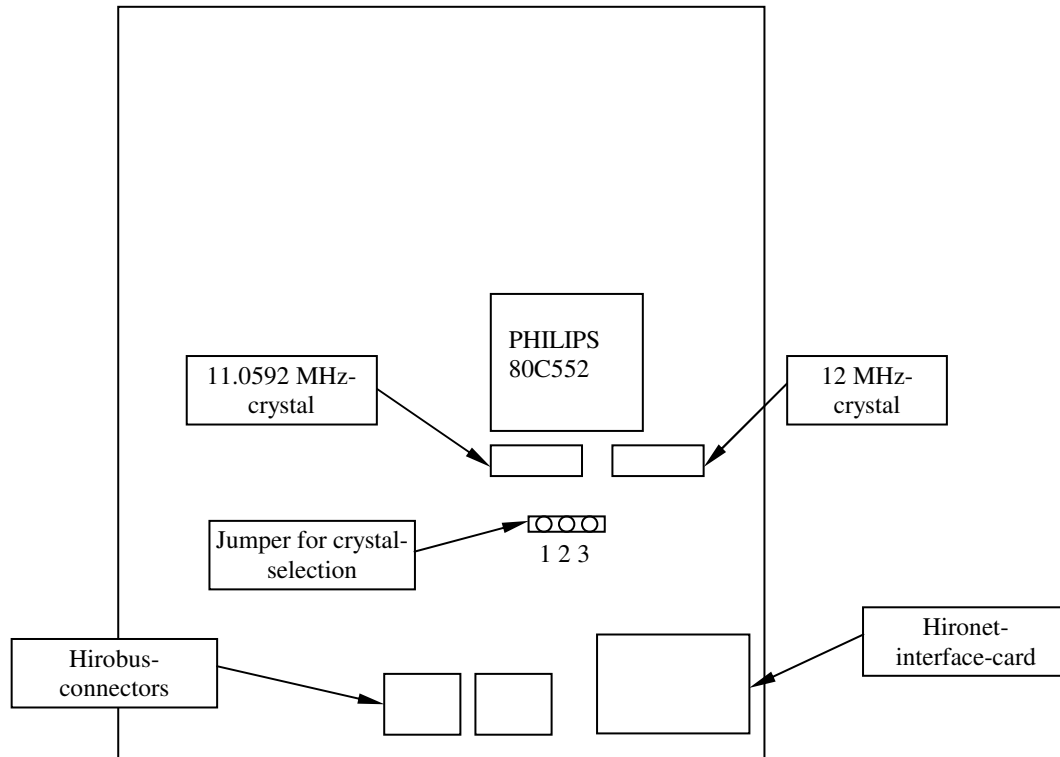

Jumper on 1 - 2: 12 MHz-crystal  
Jumper on 2 - 3: 11,0592 MHz-crystal

In that case you must change the jumper to the 12 MHz-position.

2. By mistake you have received a Hiromatic previous to hardware-version 3.5, which is equipped with only one crystal and this one is a 11,0592 MHz-crystal. In that case the Hiromatic must be replaced with one equipped with a 12 MHz-crystal.

NOTE:

Starting from 'Hirolink for Modbus V 2.81', the Hirolink has the possibility to communicate with Hiromatics using both types of crystals mentioned above simultaneously. Thus, the position of the jumper for crystal-selection is not important anymore and the baudrate displayed on the Hiromatic can match either one of possibilities listed below.

*Protocol:*

Some software-types provide a parameter called 'PROTOCOL'. If the Hiromatic displays this line the parameter must be set to 'HIROSS'. Please check the list at the end of this section for information on which software-types provide this parameter.

*Communication-Mode:*

Some software-types provide a parameter called 'COMMUNICATION ENABLED' (on some types also called 'SER. COMM. ENABLED' or 'TRANSMISSION ENABLED'). This parameter enables or disables the ability to change parameter via the Hironet. In general this parameter will be set to 'YES' to enable the BMS to change values in the Hiromatic. If the BMS only wants to read values from the Hiromatics, this parameter can be set to 'SERVICE' (sometimes also displayed as 'NO'). Please check the list at the end of this section for information on which software-types provide this parameter.

These steps must be carried out on each Hiromatic that will be connected to the Hirolink.

The following list provides the information mentioned above:

<b>Type</b>	<b>Displayed baudrate with 12 MHz- crystal</b>	<b>Displayed baudrate with 11,0592 MHz crystal</b>	<b>Parameter 'PROTOCOL' displayed</b>	<b>Parameter 'COMM. ENABLED' displayed</b>	<b>Remarks</b>
<b>CAM</b>	20833 Bd	19200 Bd	No	No	
<b>Compact Custom</b>	208	192	Yes	Yes	Set the crystal-type manually in menu 'QUARZ'
<b>Dryer</b>	No	No	No	No	All parameter are fixed
<b>Energy Partner</b>	20833 Bd	19200 Bd	No	No	
<b>Energy Partner Small</b>	20833 Bd	19200 Bd	No	No	
<b>CPU Chiller</b>	20833 Bd	19200 Bd	No	No	
<b>Advanced Graphic</b>	20833 Bd	19200 Bd	Yes	Yes	
<b>Compact Graphic</b>	20833 Bd	19200 Bd	Yes	Yes	
<b>Superchiller/Hichill (GSB, GSH)</b>	19.2 k	19200 Bd	No	No	Parameters available in menu 'HV SETTINGS'
<b>SIP</b>	208	192	Yes	Yes	Set the crystal-type manually in menu 'QUARZ'
<b>Telecool Compact</b>	20833 Bd	19200 Bd	Yes	Yes	
<b>Hiwall (HWG)</b>	20833 Bd	19200 Bd	No	Yes	
<b>Hiflex, Himod * (WXG, E1G)</b>	20833 Bd	19200 Bd	No	Yes	
<b>Hiflex, Himod * (EVGL1, EVGL2)</b>	No	19200 Bd	No	Yes	
<b>OENB</b>	20833 Bd	19200 Bd	No	Yes	
<b>Superchiller 2000 / Matrix ** (SCG)</b>	20833 Bd	19200 Bd	No	Yes	

The software-types 'Compact Custom' and 'SIP' run in a Hiromatic Compact Custom, which is not equipped with a clock. Therefore the Hiromatic has no possibility to detect the type of crystal and you have to set it manually.

\* For CCAC (Hiflex, Himod, WXG and E1G Eproms are used for Hiromatic **G**, whereas version EVGL1 AND EVGL2 are used for Hiromatic **E**, communicating with 19200 Baud only.

\*\* For Superchiller 2000 / Matrix units the Eprom-version SCG is used for Hiromatic **G**, whereas version SCE is used for Hiromatic **E**, communicating with 19200 Baud only.

**Step 3: Insert the interface-card (Hiromatic G only, Hiromatic E has the interface already on-board.)**

Be sure that a RS422-interface-card is mounted on the Hiromatic. Two versions of this interface-card are available as shown in the illustrations below:

Standard RS422-interface-card:

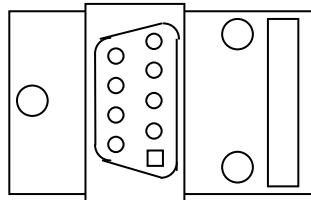

Code No. 482 992

Opto-coupled RS422-interface-card:

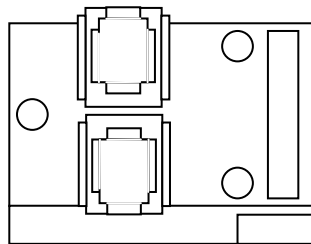

Code No. 275 631

For a detailed description of the interface-cards and their pinning see chapter 8 'Hardware-Reference'.

**Step 4a: Connect the Hiromatic G with each other**

In general there are 2 possibilities to connect the Hiromatics **G** with each other.

*RS422-network-type:*

This network-type is easier to install and therefore commonly used. You have to use a 4-wire cable, where the connection is done in a 1-to-1 manner. This means that each pin on one interface-card has to be connected to the same pin on the next interface-card.

When 'Standard RS422-interface-cards' are used the pins 1 to 4 have to be connected as shown in the following illustration (NOTE: it a general use to consider this symbol *f* as the pin 1 of the connector) :

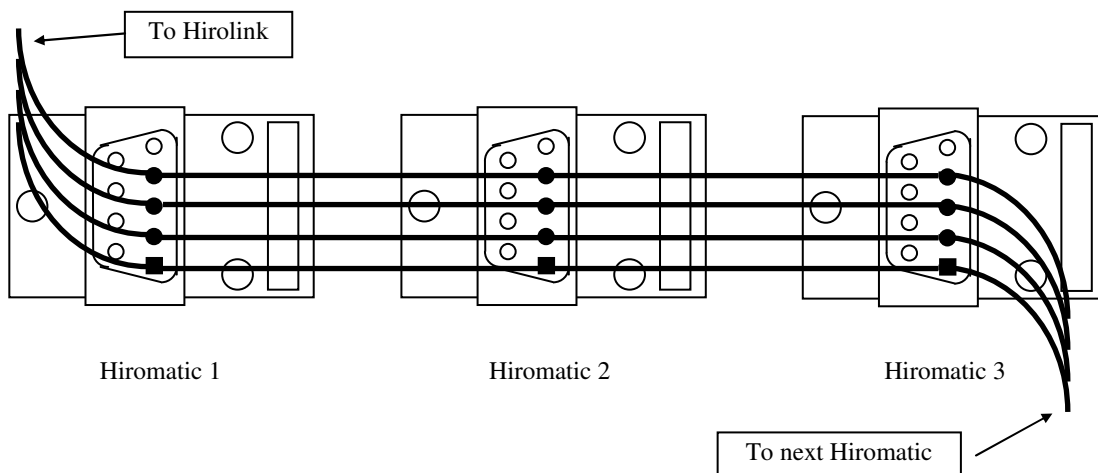

## Hirolink for Modbus V 3.00 - General Documentation

It is NOT important in which order the Hiromatics are connected, i.e. for example Hiromatic 10 can be the first physically connected Hiromatic, followed by Hiromatic 1 and so on.

For a detailed description of the interface-cards and their pinning see chapter 8 'Hardware-Reference'.

When 'Opto-coupled RS422-interface-cards' are used, you only have to mount appropriate 4-pin-modular-jacks on the cable and plug the connector in as shown in the following illustration:

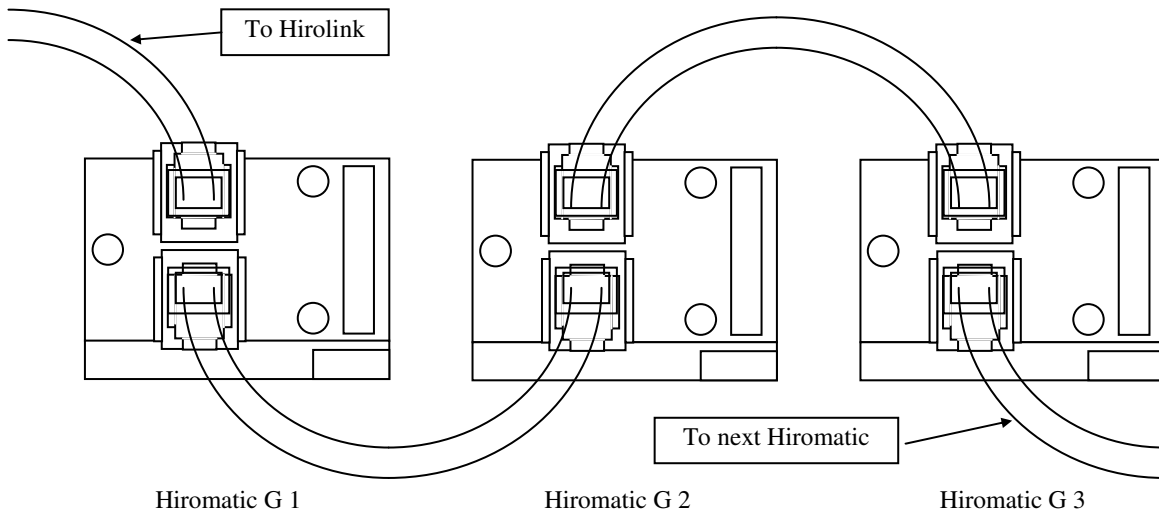

Again it is NOT important in which order the Hiromatics are connected. Also it is NOT important which of the two plugs is used for either direction.

For a detailed description of the interface-cards and their pinning see chapter 8 'Hardware-Reference'.

When you have both types of RS422-interface-cards, connect them as shown in the following illustration:

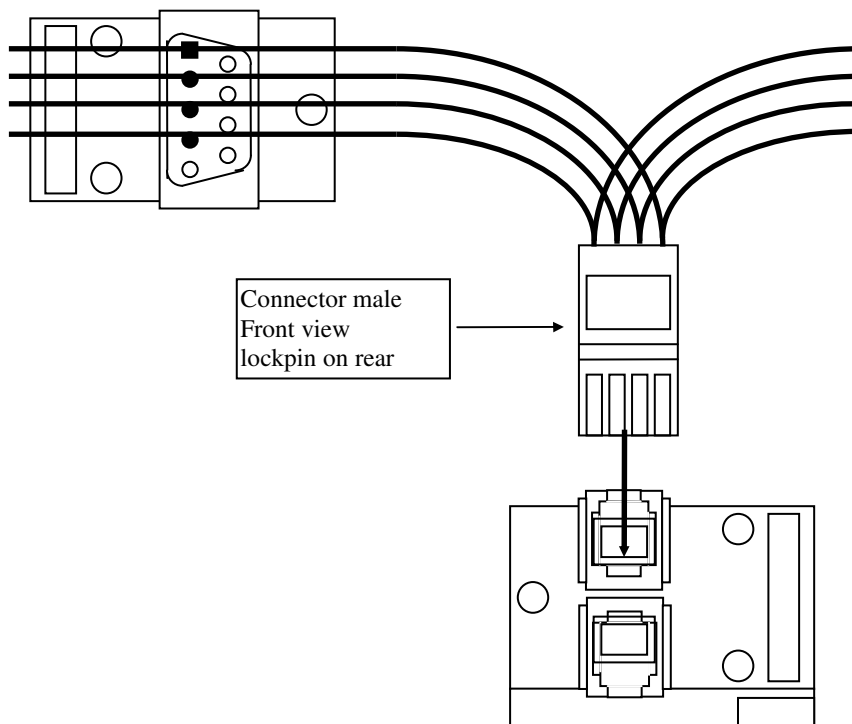

For a detailed description of the interface-cards and their pinning see chapter 8 'Hardware-Reference'.  
*RS485-network-type:*

The other possibility to connect the Hiromatic G is a RS485-network-type. The advantage that you can gain with this network-type is that you only need a 2-wire-connection between the Hiromatic G, but you have to manually shortcut two pins on each RS422-interface-card.

Since it is a lot of extra work and many mistakes can happen when shortcutting the pins, it is more advisable to use the RS422-network-type. Still if you would like to use the RS485-network-type, check chapter 8 'Hardware-Reference' for detailed information on which pins you have to shortcut.

**Step 4a: Connect the Hiromatic E with each other**

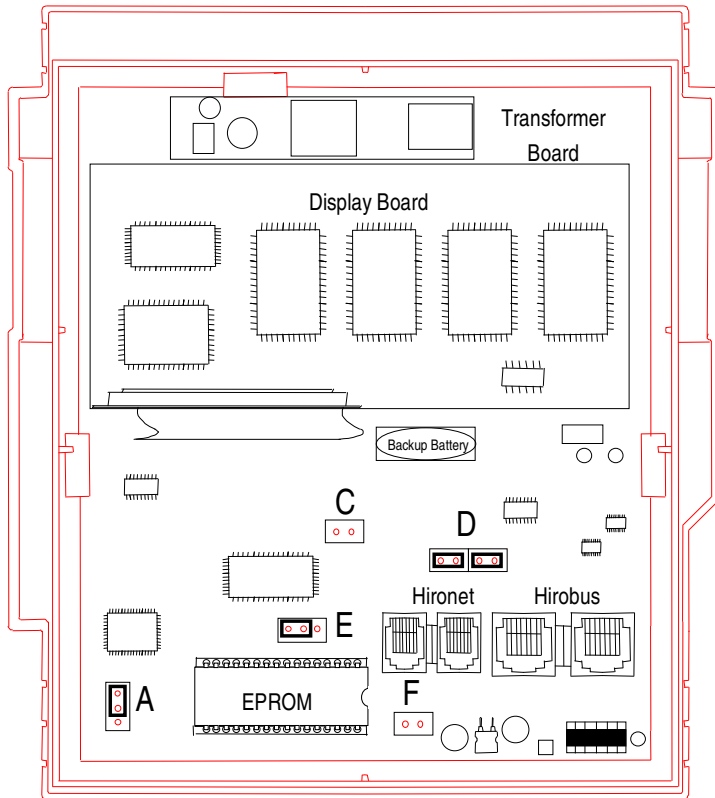

*RS422-network-type (both Jumpers "D" **NOT** set:*

This network-type is easier to install and therefore commonly used. You have to use a 4-wire cable, where the connection is done in a 1-to-1 manner. This means that each pin on one interface-card has to be connected to the same pin on the next interface-card.

Like for Hiromatic G connection with 'Opto-coupled RS422-interface-cards' , a 4-pole cable (screened, with 4-pin-modular-jacks) needs to be wired from Hiromatic E to Hiromatic E Hironet connector, in a 1-to-1 manner. Like on 'Opto-coupled RS422-interface-cards' both Hironet plugs are in parallel, the connectors may be used either way.

### 6.3 Connecting Hiromatic G and E together

As both types have different Hironet-pining, they cannot be connected 1:1, Double-cross cables (pin 1 crossed with pin 2, and pin3 crossed with pin 4) have to be inserted between Hiromatic G and Hiromatic E. Details see chapter 6.6, Connecting the Hirolink to the Hiromatics.

### 6.4 Preparing the iCOM board

- Note: there are 2 different types of **iCOM board** available:
  - **Medium board**
  - and
  - **Large board**

The following steps will describe the actions to be done for both types.

To prepare the iCOM board for a connection to the Hirolink, carry out the following actions:

#### Step 1: Check the Hironet-settings (Medium and Large boards)

In order to verify-modify the Hironet-ID-settings it is necessary to have at least the 3-Digit display connect to the iCOM board and find the "id" parameter.

These settings define the Identification-number and the baudrate and in some cases also the protocol and the communication-mode. Each of these settings is described in the following:

##### **Identification-number:**

The identification-number set on the iCOM board defines the Modbus-Slave-ID, which has to be used to request data from the iCOM board. As mentioned in the description of the protocol, this Slave-ID must be unique. Therefore it is very important that each iCOM board receives a different identification-number.

After setting the identification-number, note it together with the software-information described in step 1. It is good advise to also note the position of the iCOM board within the building.

##### **Baudrate:**

It is fixed to 19200Bd.



## Step 2: Modbus Network structure (iCOM Medium-Large connections)

### Medium board:

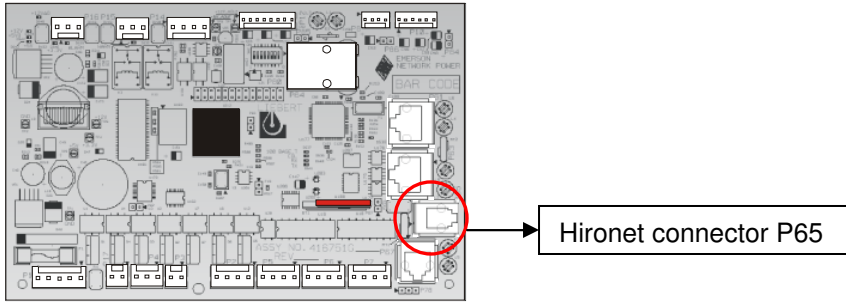

### Large board:

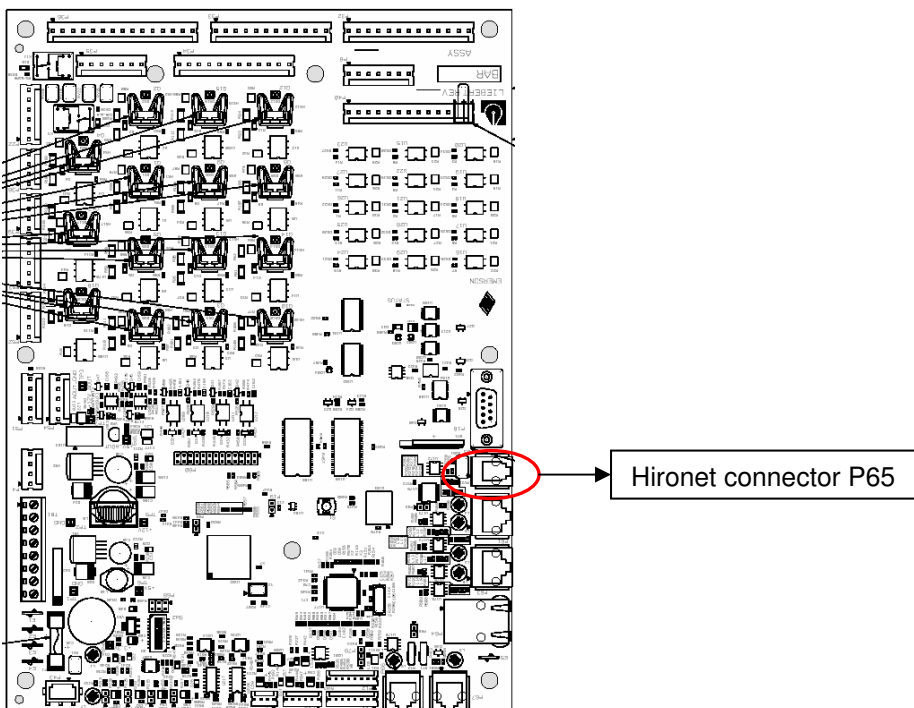

A **T-connector** for RJ9 type can be used when more iCOM board need to be connected together. The T-connector makes the connection task easier. (T-connector Code 275655).

This network-type is easier to install and therefore commonly used. You have to use a 4-wire cable, where the connection is done in a 1-to-1 manner. This means that each pin on one interface-card has to be connected to the same pin on the next interface-card.

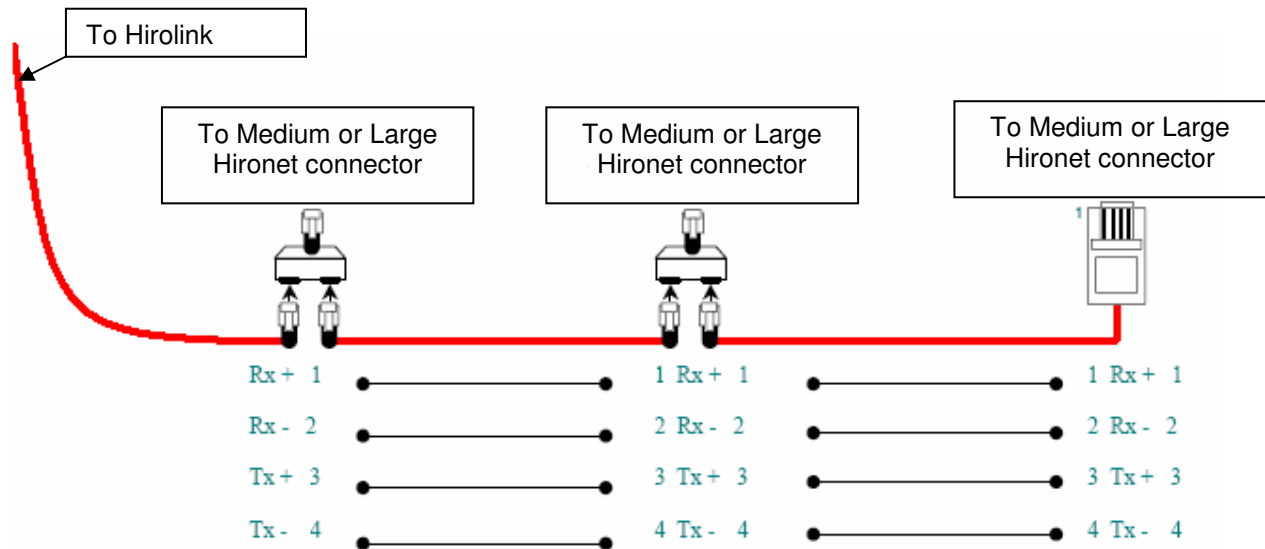

## 6.5 Preparing the Hirolink

To be able to prepare the Hirolink in a proper way, you have to be sure of the following things:

- How many Hiromatics-iCOM Boards will be connected to the Hirolink ?  
As mentioned above a maximum of 24 air conditioners can be connected to one Hirolink. It is likely, that the communication doesn't work at all, when this number is exceeded.
- What are the identification-numbers and software-versions of the connected Hiromatics ?  
Be sure to have noted the software-version and the identification-numbers together with the location of the connected Hiromatic-iCOM Board as described in chapter 6.1.

Check whether the software-versions running in the Hiromatics, iCOM Boards are supported by the Hirolink using the compatibility-list provided in appendix A of this document.

Which communication-parameters are used on the Modbus-network?

Ask the operator of the Modbus-network for the communication-parameters used on the Modbus-network. This information must include the following parameters:

### *Baudrate:*

Till the SW V2.89 the Hironet protocol is managed via RS422/485 only.  
Possible values are 110, 150, 300, 600, 1200, 2400, 4800, 9600 and 19200 Baud.

From the SW version V2.90 the Hironet protocol can be managed also via RS232. As indirect consequence the following is the table for the RS standard and the baudrate used function of the jumper settings.  
Possible values are 1200, 2400, 4800, 9600 and 19200 Baud.

### *Parity:*

Possible values are NO, EVEN and ODD.

### *Number of stop-bits:*

Possible values are 1 and 2.

### *Modbus-protocol:*

Possible values are ASCII and RTU.

### *Modbus-network-type:*

Possible values are RS232 and RS485.

### 6.5.1 Hirolink types

There are two types of Hirolink that can be used to interface a network of Hiromatics with a BMS through the Modbus protocol. The older one of the two provided 4 connectors on its front-panel as shown in the following illustration:

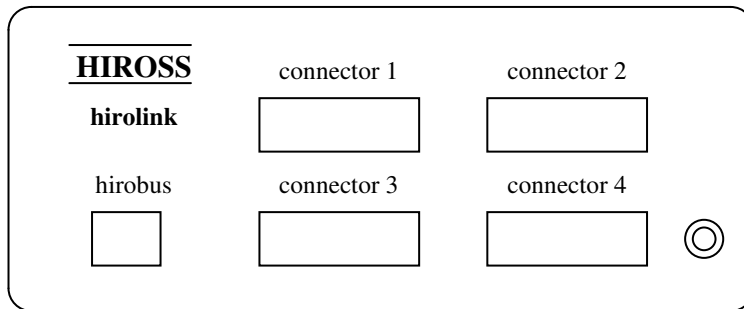

The newer type of Hirolink provides only 3 connectors on its front-panel and is named 'Hirolink classic':

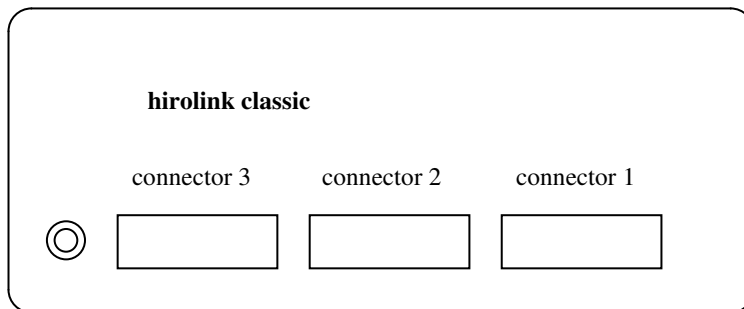

Since Hirolink type shown in the first illustration was the only type existing at this time, it had no special name except 'Hirolink'. In order to provide a distinction between this type of Hirolink and the 'Hirolink Classic', the older type will be called '4-connector Hirolink for the remainder of this document.

In the following chapters provide detailed information about the necessary steps to prepare each type of Hirolink for operation.

## 6.5.2 Inserting the interface-cards

### 6.5.2.1 Hiolink classic

To enable the communication with the Hiromatics, connector 3 of the Hiolink classic has to be configured to work as a RS422/RS485-interface as shown in the following illustration.

To enable the communication with the Modbus-network, you have to configure connector 2 of the Hiolink classic to work either as a RS232- or as a RS422/RS485-interface depending on the kind of interface used by the Modbus-network.

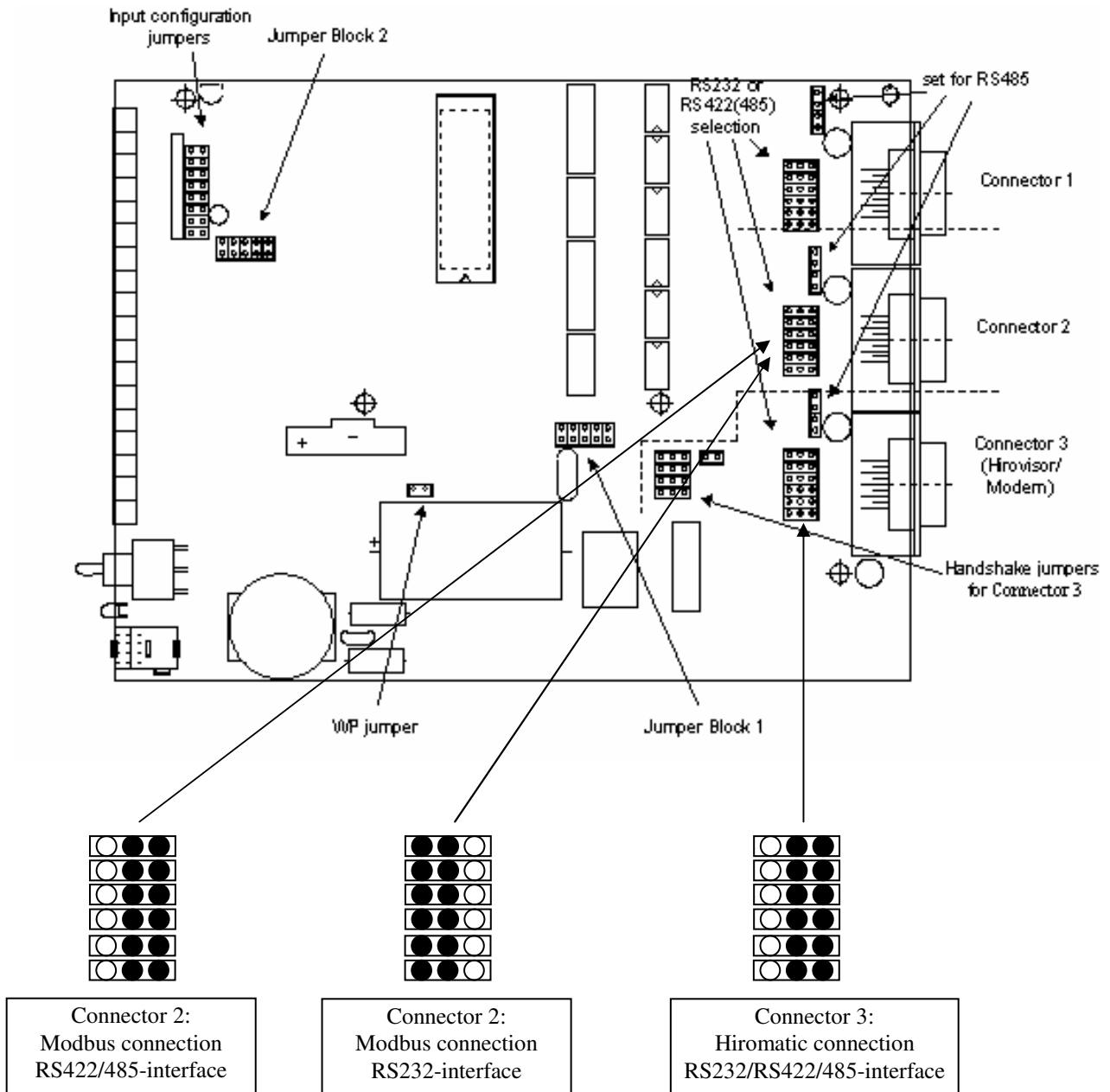

### 6.5.2.2 4-connector Hiolink

To enable the communication with the Hiromatics a RS422/RS485-interface-card has to be inserted, where no further settings are necessary.

To enable the communication with the Modbus-network, the kind of interface-card to be inserted depends on the Modbus-network-type. You have to insert a interface-card of type RS232 for a RS232-network-type or a interface-card of type RS422/RS485 for a RS485-network-type.

The reason for inserting a RS422/RS485- interface-card for a RS485-network, is that the only difference between a RS422 and RS485 is that on a RS422-network the receiving and transmitting lines are separated, while on a RS485-network receptions and transmissions are sent over the same lines. Therefore you only have to shortcut the receiving and transmitting lines on the Hiolink-connector, to make the RS422/RS485-interface-card work on a RS485-network.

The following illustration shows the sockets, where of the interface-card have to be inserted:

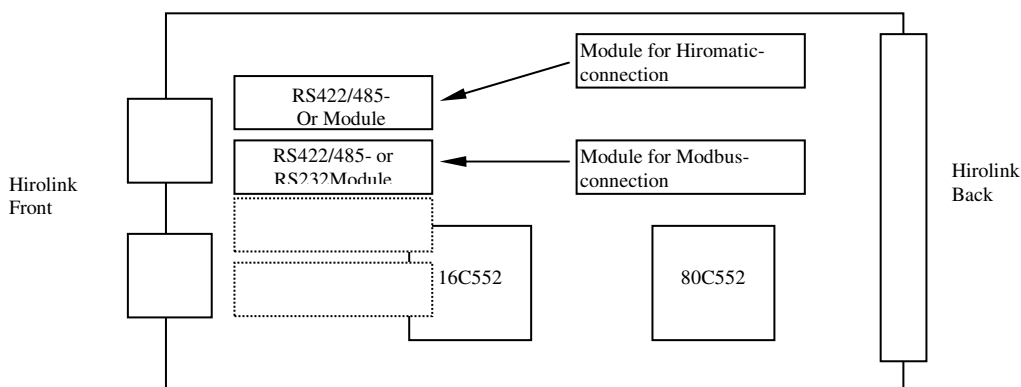

The interface-cards themselves look like the following illustrations:

RS232-interface-card:

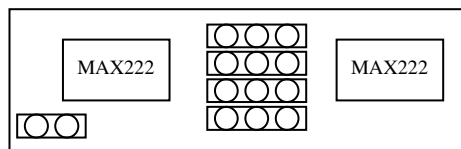

HL RS232-interface-card  
Code No. 275 701

**NOTE:** Remove all jumpers that might be set on the RS232-interface-card.

RS422/RS485-interface-card:

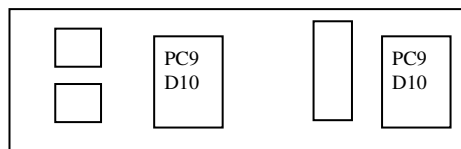

HL RS422/RS485-interface-card  
Code No. 275 700

### 6.5.3 Setting the communication-parameters for the Modbus-network

As the final step you have to configure the communication-parameters inside the Hirolink according to the information you received from the operator of the Modbus-network (see 0 'Preparing the Hirolink'). The following parameters have to be set:

- Baudrate
- Parity
- Number of stop-bits
- Modbus-protocol (ASCII or RTU)
- Modbus-network-type (RS232 or RS485)

Each type of Hirolink provides two jumper-blocks, which enable you to configure the Hirolink accordingly. See the illustrations in the following chapters for information on where to find the relevant jumper-blocks.

The information provided in following tables is valid for BOTH types of Hirolink:

Jumpers on Jumper-Block 1:

Jumper	SET	NOT SET
Communication mode	ASCII	RTU
Parity select	ODD	EVEN
Stopbits	1	2
Parity enable	DISABLED	ENABLED
Status-Report-Acknowledge*	NOT MANDATORY	MANDATORY

\* If the Status-Report-Acknowledge **is not set (MANDATORY)** the acknowledge of the alarms via BMS is MANDATORY; then in this case the alarm registers are not updated.

When the Status-Report-Acknowledge **is set (NOT MANDATORY)** the acknowledge of alarms is automatically done by Hirolink; in this case the alarm registers are updated.

When the buffer of alarms is full the oldest alarm is overwritten with the new one.

**NOTE:**

The jumper 'Parity Select' is only respected, when the transmission of a parity-bit is enabled (i.e. jumper 'Parity Enable' is not set).

ASCII-Mode uses a word-length of 7 bit, while RTU-Mode uses a word-length of 8 bit according to Modbus-protocol-specifications.

See chapter 5.4 'The Status-Report' for a detailed description of the jumper 'Status-Report-Acknowledge'.

Jumpers on Jumper-Block 2:

Jumper	SET	NOT SET
BMS Interface type	RS485	RS232

Till the SW V2.89 the Hironet protocol is managed via RS422/485 only. The already managed Modbus baudrate are supported.

Baudrate-Jumper	3	2	1	0	Baudrate
	1	1	1	1	110 Baud
	1	1	1	0	150 Baud
	1	1	0	1	300 Baud
	1	1	0	0	600 Baud
	1	0	1	1	1200 Baud
	1	0	1	0	2400 Baud
	1	0	0	1	4800 Baud
	1	0	0	0	9600 Baud
	0	1	1	1	19200 Baud

From the SW version V2.90 the Hironet protocol can be managed also via RS232. As indirect consequence the following is the table for the RS standard and the baudrate used function of the jumper settings.

Setting of baudrate:

BAUDRATE-JUMPER TABLE				
3	2	1	0	Baudrate Jumper
1	1	1	1	19200 Baud + RS232 on Hironet-side
1	1	1	0	9600 Baud + RS232 on Hironet-side
1	1	0	1	4800 Baud + RS232 on Hironet-side
1	1	0	0	2400 Baud + RS232 on Hironet-side
1	0	1	1	1200 Baud + RS485 on Hironet-side
1	0	1	0	2400 Baud + RS485 on Hironet-side
1	0	0	1	4800 Baud + RS485 on Hironet-side
1	0	0	0	9600 Baud + RS485 on Hironet-side
0	1	1	1	19200 Baud + RS485 on Hironet-side

1..Jumper set  
0..Jumper not set

### 6.5.3.1 Hirolink classic

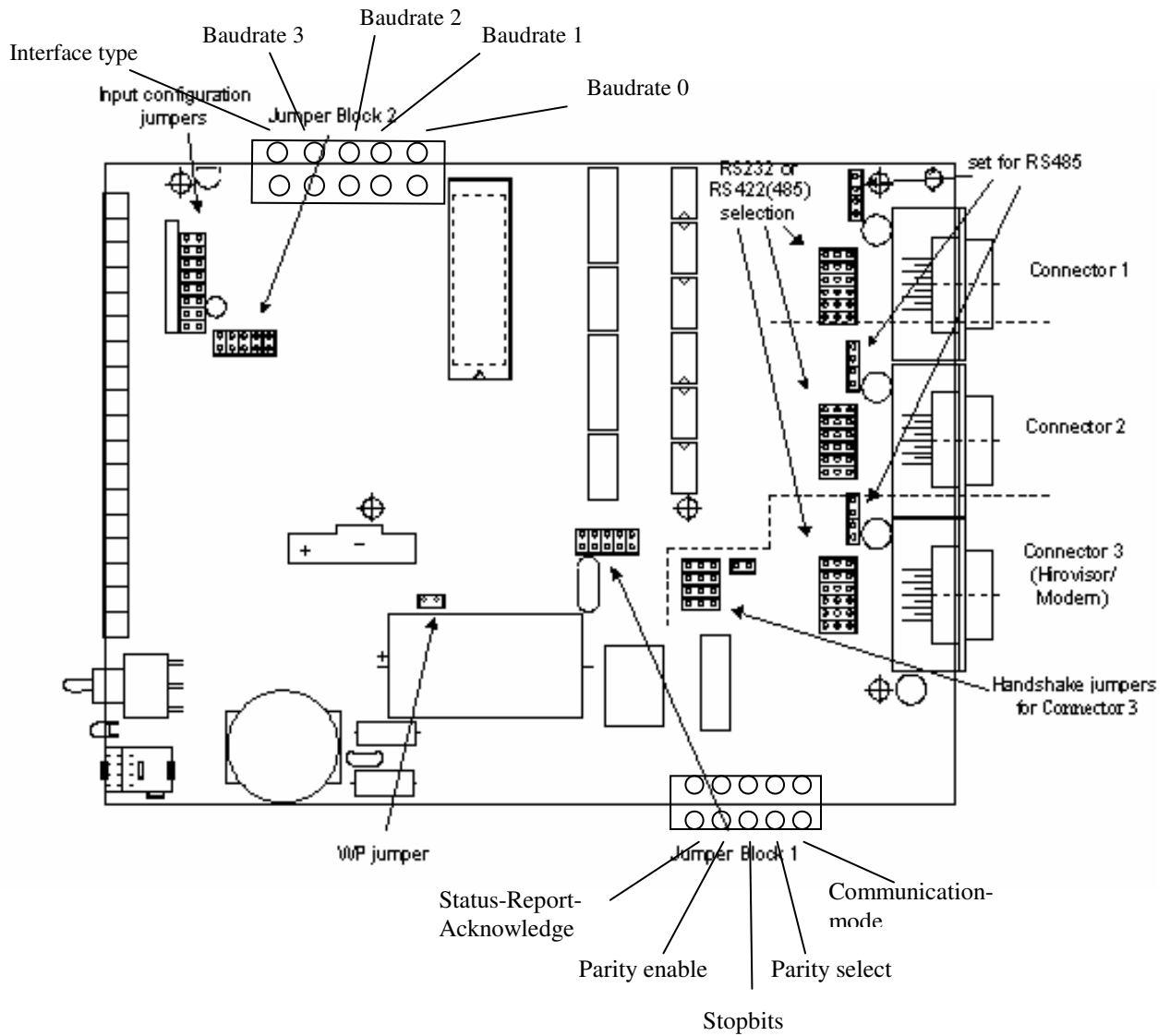

6.5.3.2 4-connector Hiolink

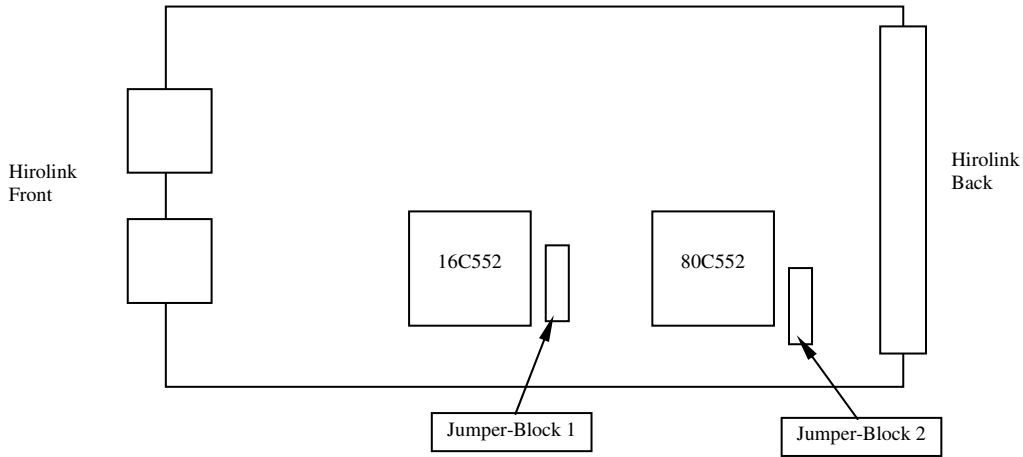

Jumper Block 1:

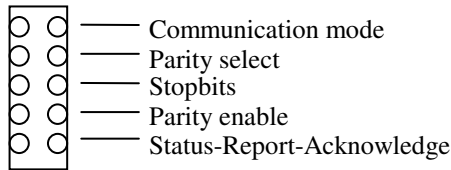

Jumper Block 2:

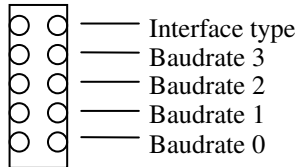

Jumpers on Jumper-Block 2:

Jumper	SET	NOT SET
BMS Interface type	RS485	RS232

Till the SW V2.89 the Hironet protocol is managed via RS422/485 only.

The already managed Modbus baurate were supported.

From the SW version V2.90 the Hironet protocol can be managed also via RS232. As indirect consequence the following is the table for the RS standard and the baudrate used function of the jumper settings.

Setting of baudrate:

Baudrate-Jumper table					Baudrate Jumper
3	2	1	0		
1	1	1	1	19200 Baud + RS232 on Hironet-side	
1	1	1	0	9600 Baud + RS232 on Hironet-side	
1	1	0	1	4800 Baud + RS232 on Hironet-side	
1	1	0	0	2400 Baud + RS232 on Hironet-side	
1	0	1	1	1200 Baud + RS485 on Hironet-side	
1	0	1	0	2400 Baud + RS485 on Hironet-side	
1	0	0	1	4800 Baud + RS485 on Hironet-side	
1	0	0	0	9600 Baud + RS485 on Hironet-side	
0	1	1	1	19200 Baud + RS485 on Hironet-side	

1..Jumper set  
0..Jumper not set



## 6.6 Connecting the Hirolink to the Hiromatics, iCOM boards

To connect the Hirolink to the Hiromatics you have to connect the cable coming from the Hiromatics (see chapter 6.2 'Preparing the Hiromatic' 6.4 'Preparing iCOM Board') to one of the connectors on the Hirolink-front panel. The layout of the 4-connector Hirolink's front-panel has been changed some time ago, but there are still both versions around:

Previous layout of the 4-connector Hirolink-front panel:

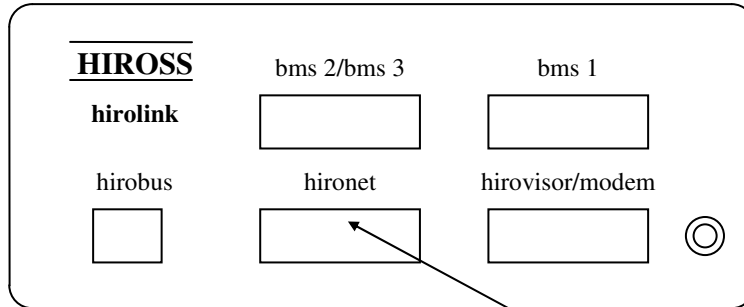

Current layout of the 4-connector Hirolink-front panel:

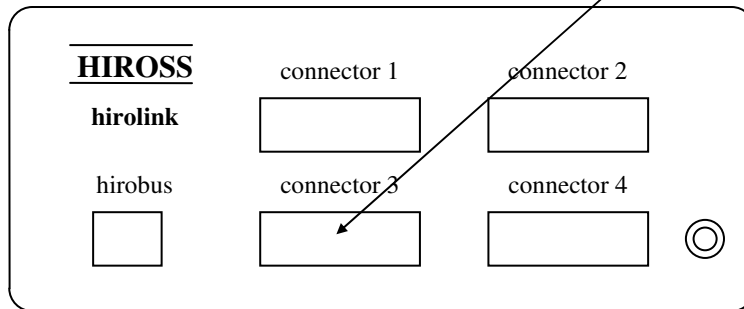

In both cases the same connector is used. On the previous layout this connector was named 'Hironet', on the current layout this connector is named 'connector 3'.

Hirolink classic:

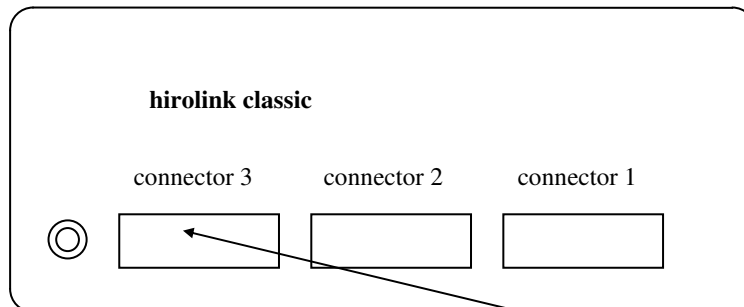

Depending on the way in which the Hiromatics were connected to each other (see chapter 6.2 'Preparing the Hiromatic' 6.4 'Preparing iCOM Board'), the connection to the Hirolink has to be done in one of the following ways:

*RS422-network-type:*

The following illustration shows the connection between Hirolink and Hiromatic **G**, when 'Standard RS422/485-interface-cards' are used (NOTE: it is a general use to consider this symbol *f* as the pin 1 of the connector):

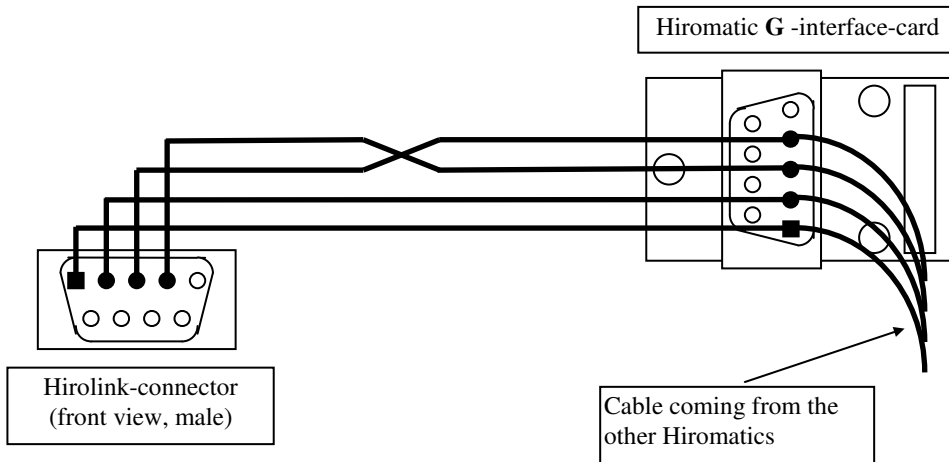

For a detailed description of the interface-cards and their pinning see chapter 8 'Hardware-Reference'.

The following illustration shows the connection between Hirolink and Hiromatic **G**, when 'Opto-coupled RS422/485-interface-cards' are used:

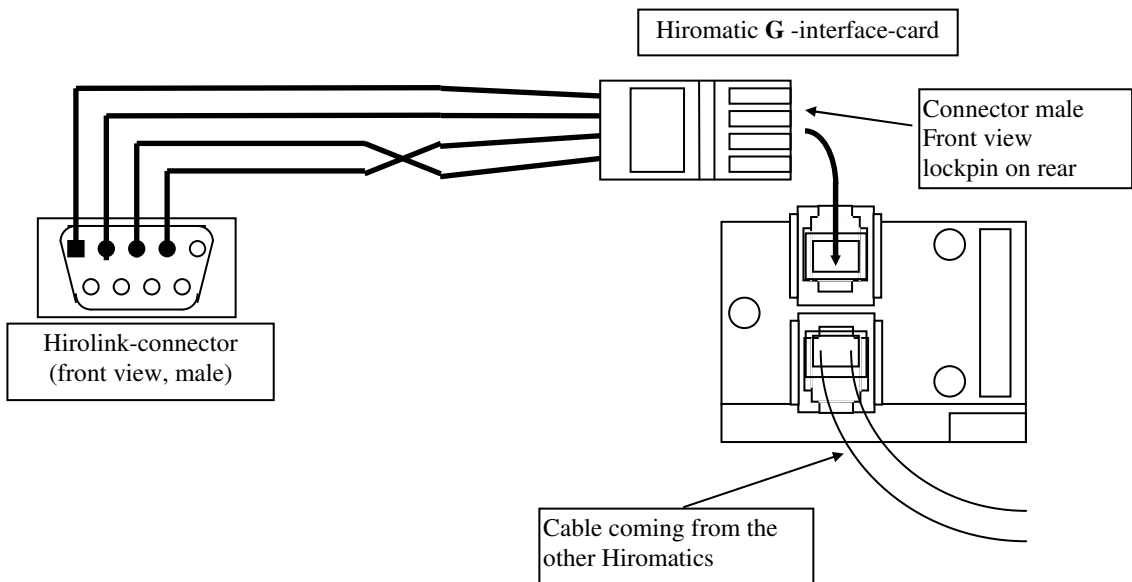

For a detailed description of the interface-cards and their pinning see chapter 8 'Hardware-Reference'.

The following illustration shows the connection between Hirolink and Hiromatic **E** or iCOM boards, when 'Opto-coupled RS422/485-interface-cards' are used:

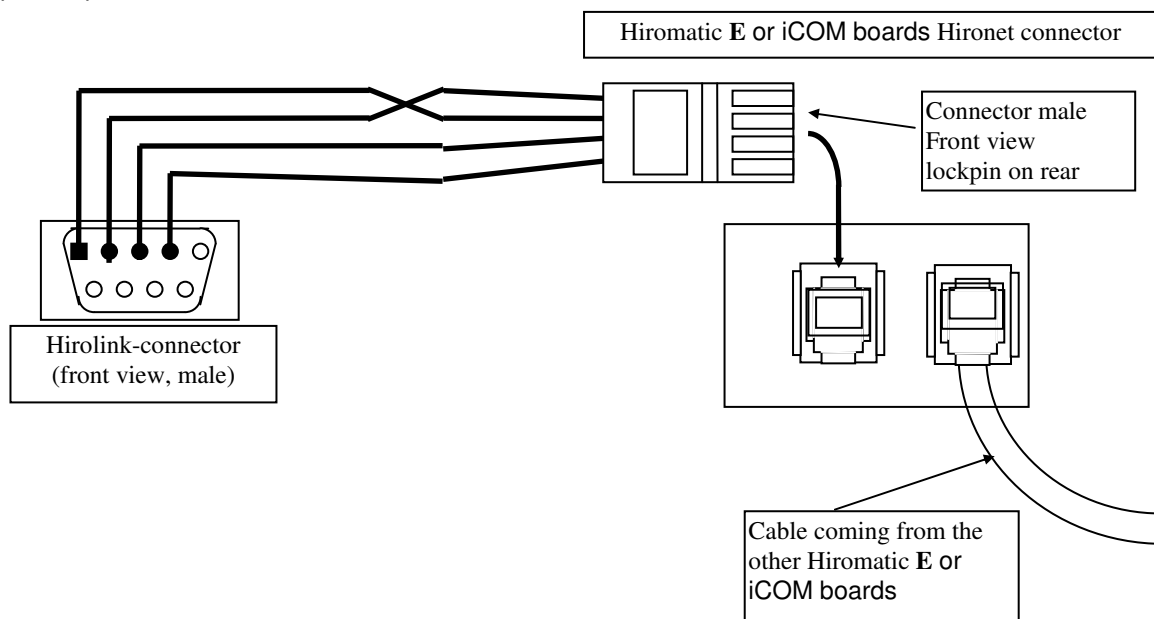

### Mixed installations with Hiromatic **G** and Hiromatic **E** or iCOM boards

Hiromatic **G**'s are connected 1:1 to each other, and cross 3 and 4 before to connect to the Hirolink.

Hiromatic **E**'s are connected 1:1 to each other, and cross 1 and 2 before to connect to the Hirolink.

Therefore a double cross (1 with 2, and 3 with 4) has to be used to connect Hiromatic **E** and **G** together. If, at the Hirolink side, 1 and 2 have to be crossed or 3 and 4 needs to be crossed, depends on which type, **E** or **G** is the last in the line, see following illustrations:

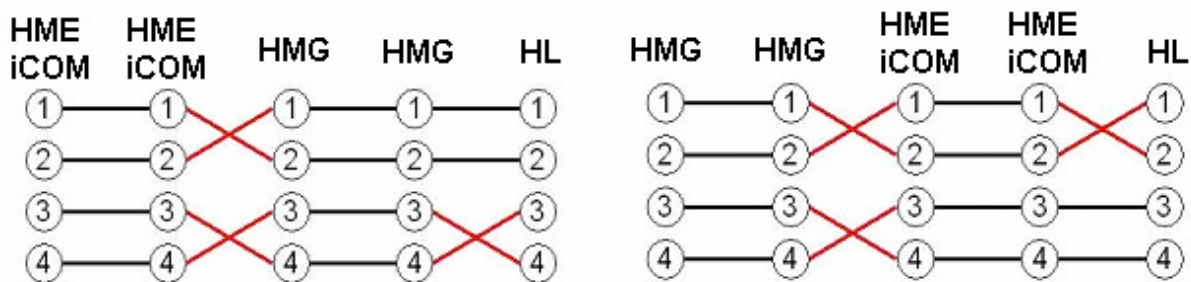

#### RS485-network-type:

If you have used a RS485-network-type to connect the Hiromatics with each other, you also have to shortcut two pins at the Hirolink. See chapter 8 'Hardware-Reference' for detailed information on which pins you have to shortcut.

For instructions on how to test the connection to the Hiromatics, see chapter 7.

## 6.7 Connecting the Hirolink to the Modbus-network

To connect the Hirolink to the Modbus-network you have to connect the cable coming from the Modbus-network to one of the connectors on the Hirolink-front-panel. The layout of the 4-connector Hirolink's front-panel has been changed some time ago, but there are still both versions around:

Previous layout of the 4-connector Hirolink front-panel:

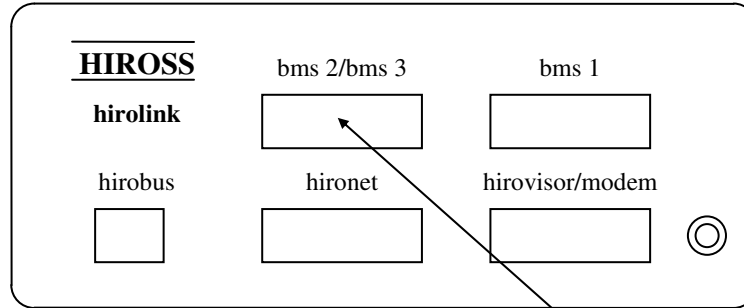

Current layout of the 4-connector Hirolink-front-panel:

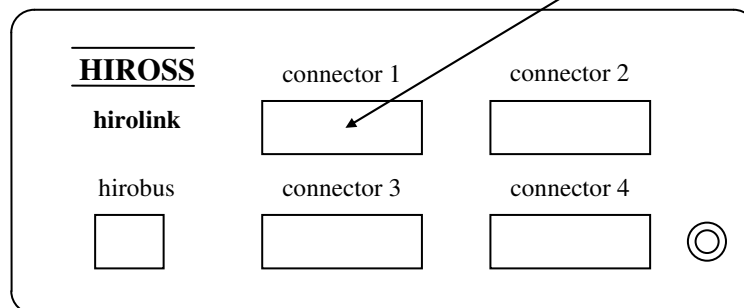

In both cases the same connector is used. On the previous layout this connector was named 'bms2/bms3', on the current layout this connector is named 'connector 1'.

Hirolink classic:

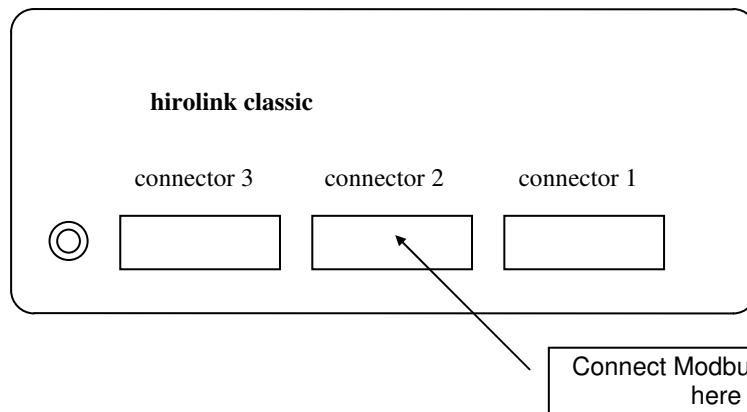

The type of connection to be made depends on the type on Modbus-network, which can be either a RS232- or a RS485-network. This information has to be received from the operator of the Modbus-network and the Hirolink has to be prepared accordingly by inserting either a RS232- or RS422/RS485-interface-card.

Depending on the Modbus-network-type, the connection to the Hirolink has to be done in one of the following ways:

*RS232-network-type:*

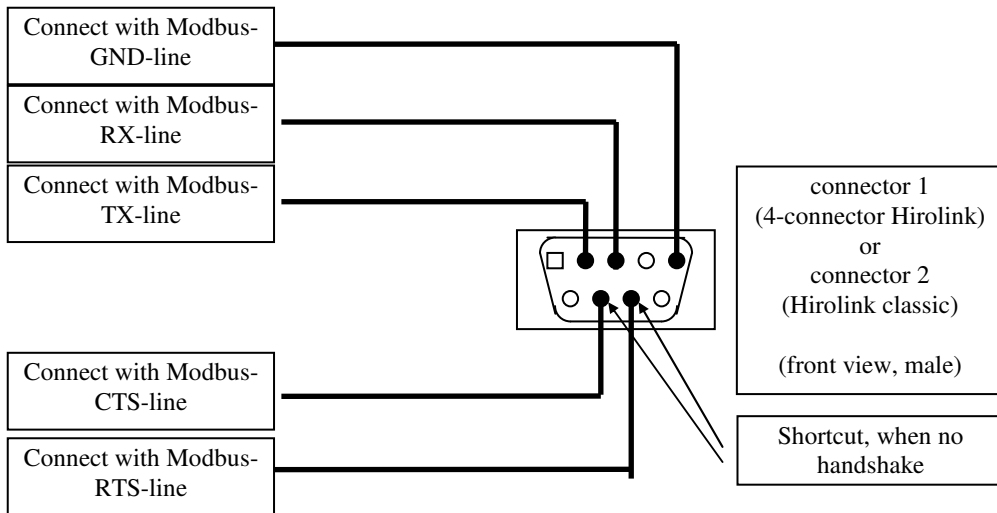

In some cases no handshake-lines are used on the Modbus-network (information about that also has to come from the operator of the Modbus-network). In that case the two lines usually used for handshaking, have to be shortcut on the Hirolink as shown in the illustration.

For a detailed description of the connector-pinning see chapter 8 'Hardware-Reference'.

*RS485-network-type:*

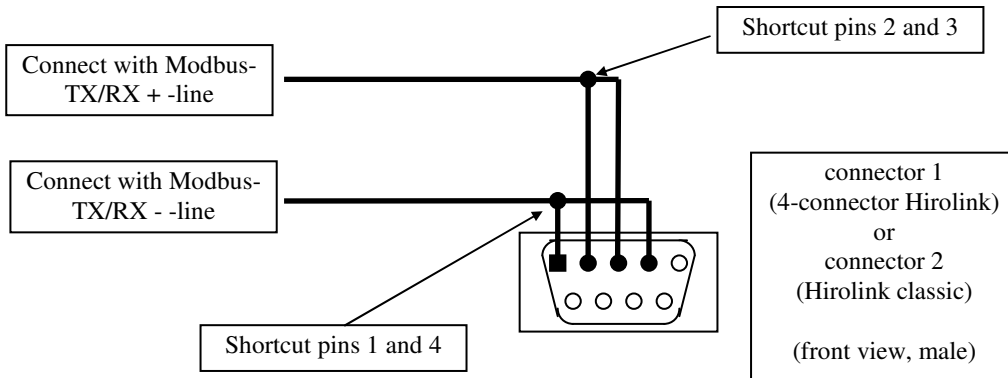

For a detailed description of the connector-pinning see chapter 8 'Hardware-Reference'.

For instructions on how to test the connection to the Modbus-network, check chapter 7 'Testing the Installation'.

## 7. Testing the Installation

### 7.1 Using the Hirolink-LEDs

The simplest form of testing the installation is to check the LEDs (Light Emitting Diode) mounted on the front-panel of the Hirolink:

4-connector Hirolink:

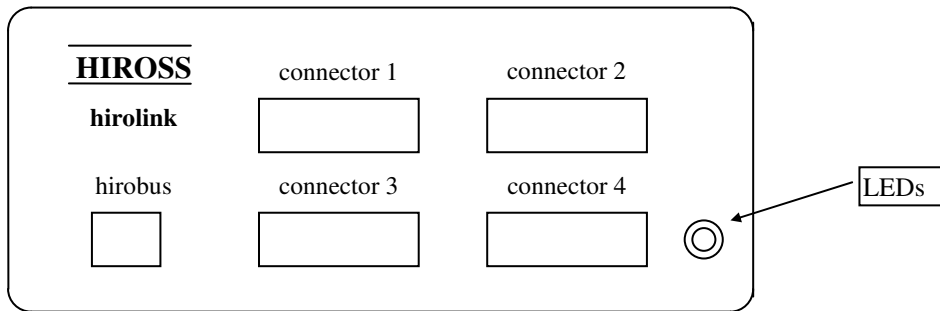

Hirolink classic:

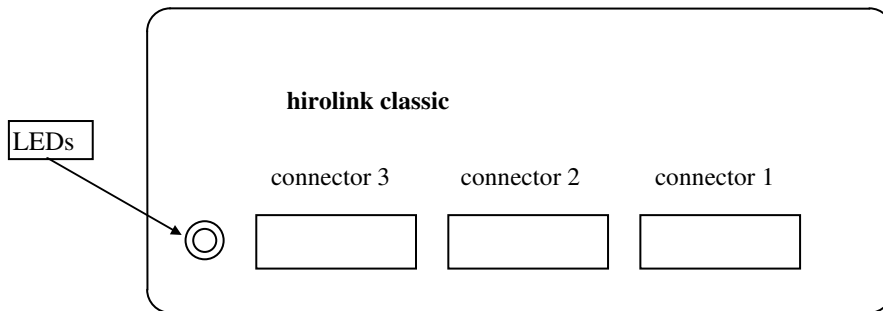

Although not visible on first sight, this LED is capable of showing two colors, GREEN and RED. Be aware that depending on your viewpoint, sometimes one LED is hard to see if the other one is already switched on.

### 7.1.1 Green LED

The Hirolink switches on the green LED as soon as it establishes a connection with at least 1 Hiromatic on the Hironet.

This LED can only be used to make the first basic test of the connection. It assures you only that the connection to the physically first Hiromatic on the Hironet is working. It doesn't provide information, if all Hiromatics that should be connected have really been found.

The LED must stay on permanently. If it goes off after a certain time and is switched back on after a while, goes off again and so on, this means that you either have an address-conflict (2 or more Hiromatics with the same address) on the Hironet or that you have a Hiromatic connected that is not compatible.

If the Hirolink is not receiving any requests from the Modbus-network, the green LED will flicker in an interval of 30s. This happens because the Hirolink reinitializes its drivers, if it doesn't receive anything from the Modbus-network. This flickering of the LED can clearly be distinguished from the switching described in the paragraph above.

### 7.1.2 Red LED

The Hirolink switches on the red LED as soon as it has received a valid transmission from the Modbus-Network. It will be switched off again after 2 seconds.

This LED can be used to test the connection between the Hirolink and the Modbus-network. If it comes on this means that the Hirolink was able to correctly receive and decode the transmission.

From the hardware point-of-view this is a pretty good test for the connection to the Modbus-network, but it doesn't mean that everything is working. What it confirms is that the communication-parameter-settings are correct and that at least the receiving line of the Hirolink was connected in the right way.

What it doesn't say for example is which data was requested or written to. This means that the request was probably not reading (or writing) the data-points that should be displayed somewhere on the Modbus-network.

Also it doesn't say that the request was made for the correct slave-address. This means that it could be that the data-point was requested from a different Hiromatic than intended.

And finally it doesn't confirm that the answer sent by the Hirolink was correctly received by the Modbus-master. But if that's the case then probably only the transmitting line or the handshake-lines of the Hirolink were not connected in a correct way.

## 7.2 Application 'MODBUS.EXE'

'MODBUS.EXE' is a simple DOS-application, which enables you to issue Modbus-protocol requests from a PC to the Hirolink. Using this application you can test all Modbus-functions the Hirolink has implemented with exception of the 'Diagnostic'-functions (see chapter 4.3 'Modbus-Functions').

**NOTE:**

The application is only able to communicate in ASCII-Mode. Communication in RTU-Mode is not possible.

### 7.2.1 Connecting the Hirolink with the PC

As described above, the Hirolink is able to communicate over a RS232- or a RS485-connection. Also when testing the Hirolink with 'MODBUS.EXE' you can make the connection in both ways, but you have to make sure that the correct interface-cards are inserted in the Hirolink and the jumper-settings have been made accordingly (see chapter 0 'Preparing the Hirolink'). The Hirolink-connector to which the PC has to be connected is the same as shown in chapter 6.7 'Connecting the Hirolink to the Modbus-network'.

### 7.2.2 Connection to a RS232-COM-port

In most cases you will use a RS232-connection, because standard PCs only provide this kind of COM-ports. The following illustrations show how to connect the Hirolink to a standard PC-COM-port:

Connection to a 9-pin PC-connector:

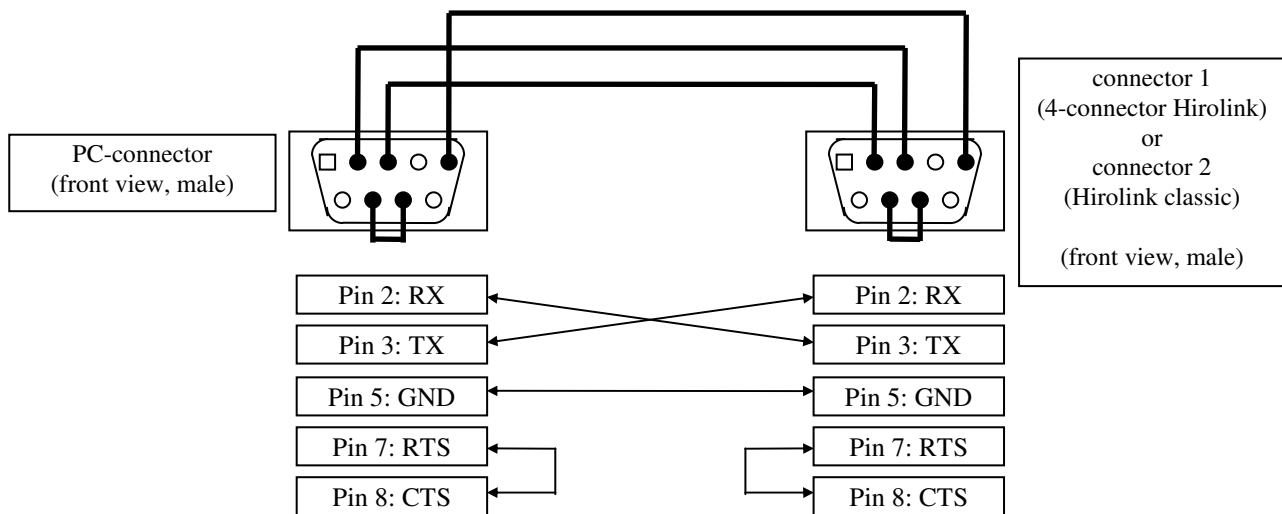



Connection to a 25-pin PC-connector:

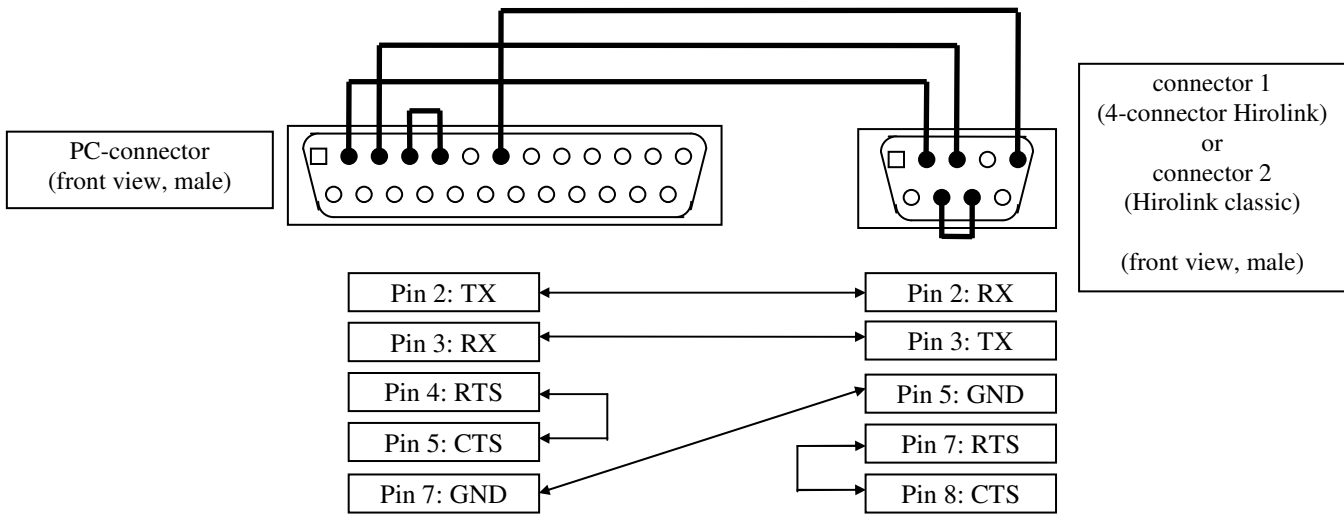

7.2.3 Connection to a RS485-COM-port

If you have a RS485-COM-port installed in your PC or if you have a RS232-485-converter, you can also make a RS485-connection. Because the connector-pinning of RS485-COM-ports and RS232-485-converters is not standardized, you would have to check the manual of your COM-port or converter for information on the pin-numbers to which you have to connect the Hirolink-lines:

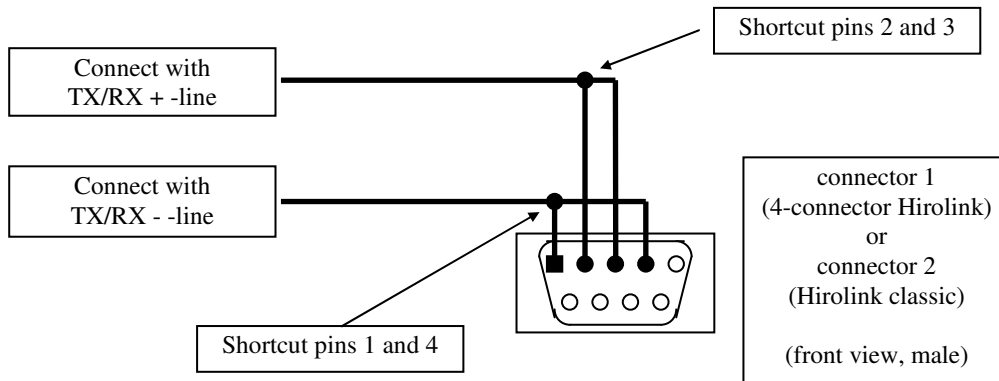

## 7.2.4 Using the application

To start the application simply change to the directory containing the application, type 'MODBUS' and press <ENTER>.

In general the application is used in the following way:

To perform a certain function enter the number displayed in front of the text describing the function and press <ENTER>. The following list describes the available functions in more detail:

1. Read coils:  
Enables you to read the coil-registers provided by a given Hiromatic.
2. Read input status:  
Enables you to read the input-status-registers provided by a given Hiromatic.
3. Read holding registers:  
Enables you to read the holding-registers provided by a given Hiromatic.
4. Read input registers:  
Enables you to read the input-registers provided by a given Hiromatic.
5. Force single coil  
Enables you to set one coil-register provided by a given Hiromatic.
6. Preset single register:  
Enables you to set one holding-register provided by a given Hiromatic.
7. Read all holding-registers (RS-OPEN):  
This function should only be used with the 'Hirolink for RS-Open'.
8. Read all input-registers (RS-OPEN):  
This function should only be used with the 'Hirolink for RS-Open'.
9. Continuously read holding-registers:  
Enables you to continuously read the holding-registers provided by a given Hiromatic. In contrast to function '3. Read holding-registers' this function reads the registers not only once, but keeps reading them in a changeable interval. The default interval is 1000 ms and can be increased or decreased by pressing 'U' (Up) or 'D' (Down) respectively.
10. Continuously read input-registers:  
Enables you to continuously read the input-registers provided by a given Hiromatic. In contrast to function '4. Read input-registers' this function reads the registers not only once, but keeps reading them in a changeable interval. The default interval is 1000 ms and can be increased or decreased by pressing 'U' (Up) or 'D' (Down) respectively.
11. Communication Parameters:  
Enables you to change the used COM-port, baudrate, parity and number of stop-bits. Be aware that the application is only able to communicate in ASCII-Mode. Communication in RTU-Mode is not possible.
12. Exit:  
Exits the application.

All functions that perform reading of data will ask you for the following information, after the function has been selected:

1. Unit ID (1-99):

Enter the Hiromatic-ID from which you want to read data.

2. Item start (1-9999):

Enter the first register number you want to read. The register-numbers correspond with the register-numbers contained in the documents issued for each Hiromatic-type. These documents are called 'Hirolink for Modbus V X.XX - Items for YYY-Units V Z.ZZ', where 'X.XX' specifies the Hirolink-version, YYY specifies the Hiromatics software-type and Z.ZZ specifies the software-version of the Hiromatic software.

3. Item amount (1-9999):

Enter the number of registers (starting from the register entered before) you want to read. Be aware that the maximum transmission length is 256 bytes, which puts limits on the maximum number of registers you can read in one transmission:

Coil- and Input-status-registers: 976

Holding- and Input-registers: 61

After all parameters have been entered, the application will send the transmission to the Hirolink.

If the Hirolink is able to respond, you will see the received data on the screen. The complete transmission and reception will be displayed in the top-lines of the screen in the same way as they were put on the line. The response-time of the Hirolink will be displayed in the bottom-line of the screen.

If the Hirolink doesn't respond, you will see the message 'Timeout Error' on the screen. Possible reasons for this are that the Hirolink is not properly connected or that you were trying to request data from a Hiromatic that is not connected to the Hirolink.

If the Hirolink responds with the message 'Not Acknowledged', you have been trying to request registers that are not defined.

Functions that perform writing of data will also ask you for the value to write. When writing coils you have to enter '0' or '1'. When writing holding-registers you have to enter the value you want to write. In this case you have to respect the format in which the value is transmitted and the range of the value (this information is provided in the documents describing the available items for the Hiromatic-type):

For example:

The following list is an excerpt of the holding-registers of the document 'Hirolink for Modbus V 2.74 - Items for Compact Graphic-Units V 2.60+'

Register #	Usage	Range; Unit	SW-Version
1	Status-Report-Acknowledge	See description below	2.60+
2	Temperature-setpoint	150 - 500; [1/10 °C]	2.60+

The 'Temperature-setpoint' is transmitted in 1/10 °C. This means that a setpoint-value of 23,5 °C is transmitted as 235. When writing the value you have to multiply the desired value by 10 and when reading you have to divide the received value by 10 to get the 'real' value.

The range of the value is 150 to 500, which corresponds to 15,0 to 50,0 °C. The Hirolink doesn't check the value before sending it to the Hiromatic. Therefore you **MUST NOT** write values that are out of their valid range. Doing this will cause the Hiromatic to report a 'RAM-Error', which as a consequence switches off the air-conditioner.

After all parameters have been entered the application will send the transmission to the Hirolink.

If the Hirolink responds correctly to the write-function, the application will automatically re-read the value until the read value is the same as the one written. You can interrupt this reading by pressing any key.

If the Hirolink doesn't respond, you will see the message 'Timeout Error' on the screen. Possible reasons for this are that the Hirolink is not properly connected or that you were trying to write data to a Hiromatic that is not connected to the Hirolink.

If the Hirolink responds with the message 'Not Acknowledged', you have been trying to write a register that is not defined.

### 7.3 Service-Interface

The 'Service-Interface' provides the possibility to request connection-information from the Hirolink either without using the Modbus-network at all or in parallel to requests from the Modbus-network.

The 'Service-Interface' can be used with any PC running a terminal program like 'TERMINAL' (comes with Windows 3.11), 'HYPER TERMINAL' (comes with Windows 95) or others.

The 'Service-Interface' can also be used with a modem, which means that instead of connecting a PC directly to the Hirolink, you can also connect a modem and call the Hirolink from remote.

#### 7.3.1 Inserting the interface-card

To make use of the service-interface you have to insert another RS232-interface-card in the Hirolink as shown in the following illustration:

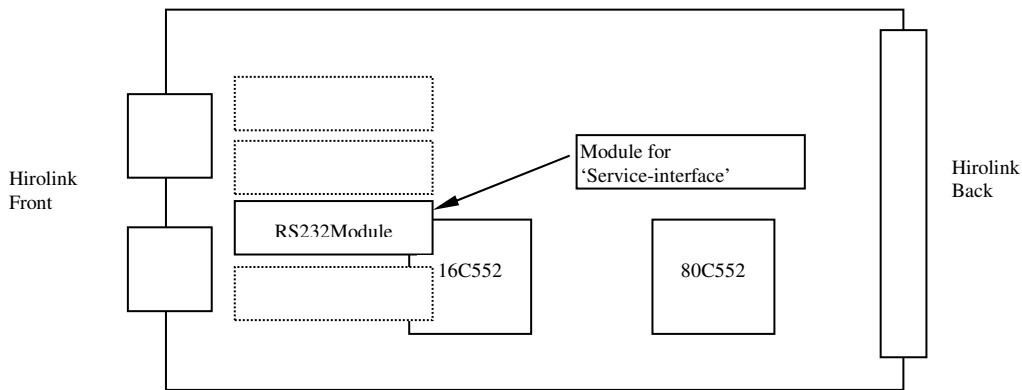

The interface-card looks like the following illustrations:

RS232-interface-card:

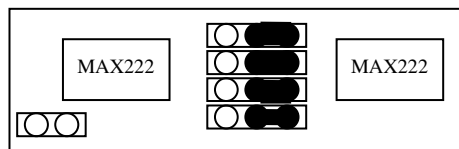

HL RS232-interface-card  
Code No. 275 701

**NOTE:**

If you want to use the service-interface via a modem, you have to set the jumpers as shown. Otherwise all jumpers can be removed.

In the new Hirolink Classic the Service-interface can be used through connector 1:

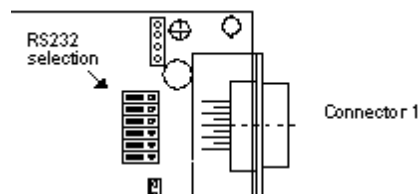

### 7.3.2 Connecting the Hirolink with the PC

After the interface-card is inserted, you have to connect the Hirolink to the PC running the terminal-program as shown in the following illustrations:

Previous layout of the 4-connector Hirolink-front-panel:

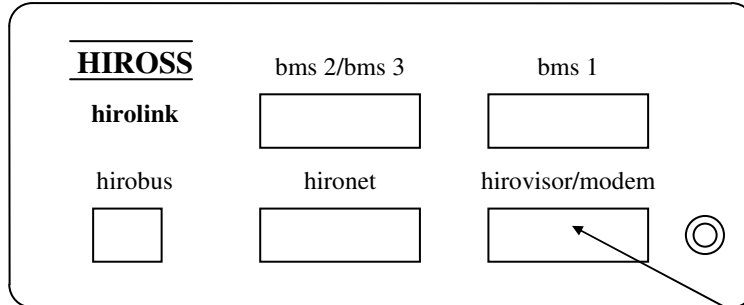

Current layout of the 4-connector Hirolink-front-panel:

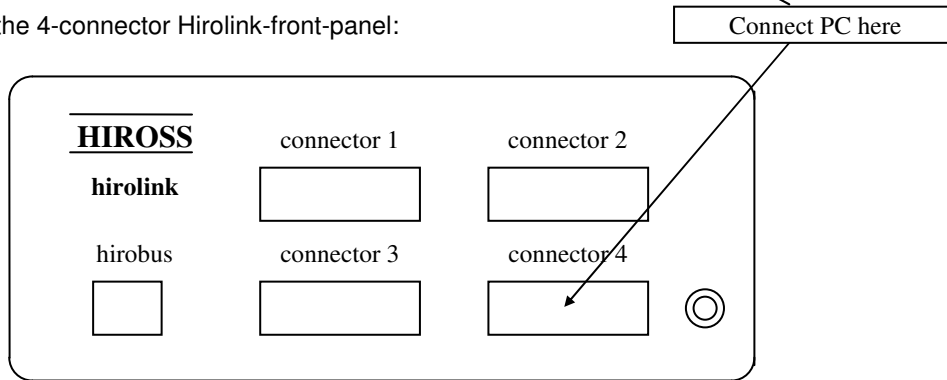

And with the new Hirolink Classic the front panel

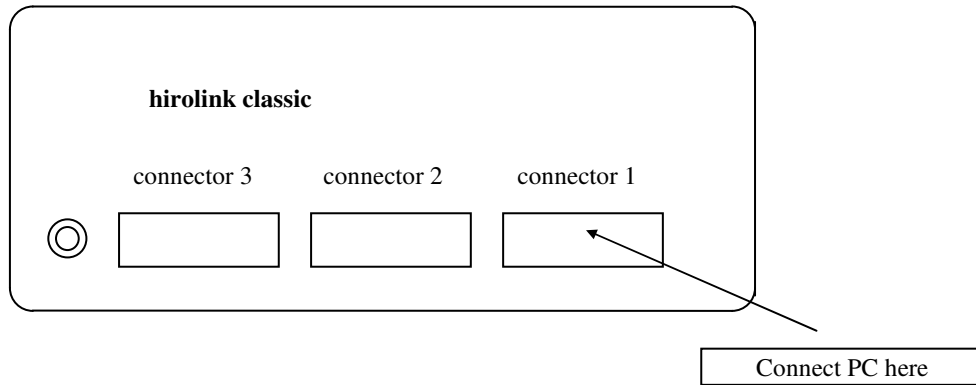

Connection to a 9-pin PC-connector:

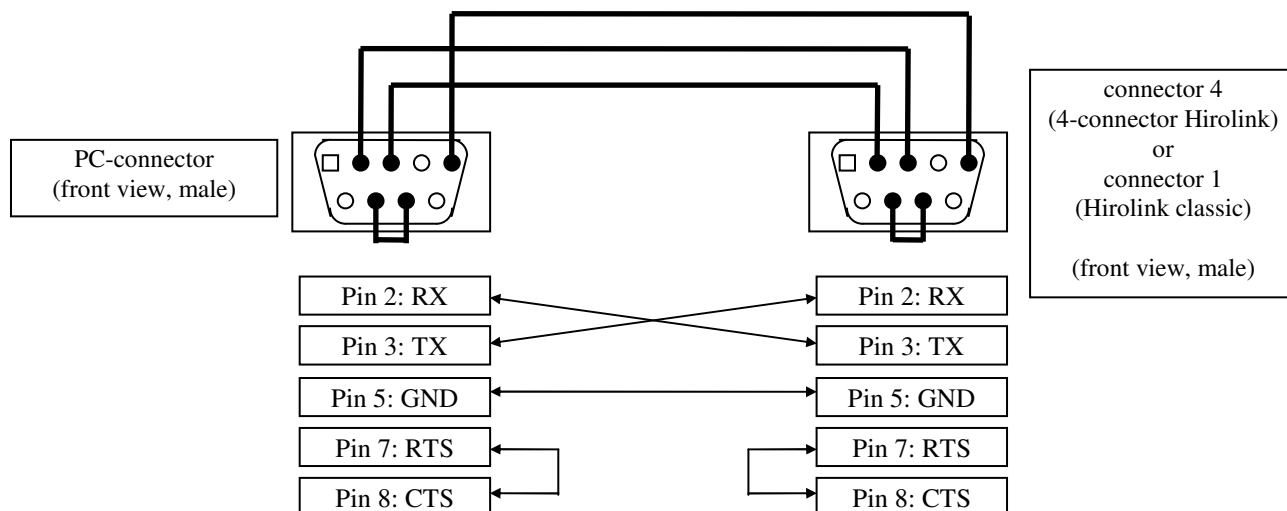

Connection to a 25-pin PC-connector:

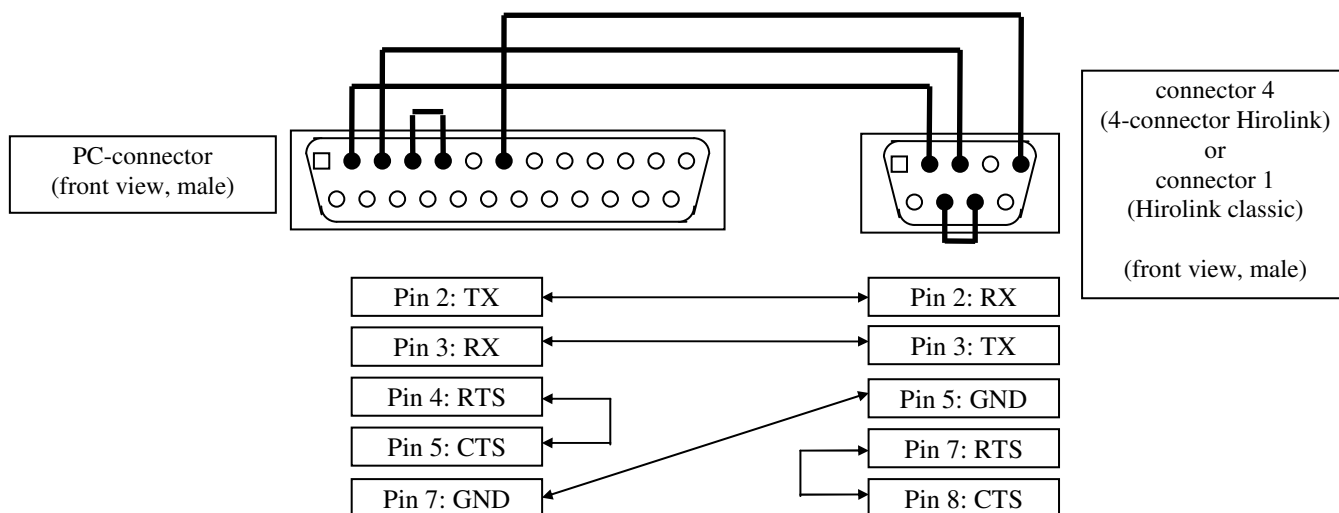

### 7.3.3 Connecting the Hirolink with a modem

If you want to connect a modem instead of a PC, use the cable that comes with the modem and connect it to the same Hirolink-connector that is used when connecting a PC.

One important issue when connecting a modem is, that you have to pre-configure the modem in such a way, that it only sends the string 'CONNECT', when a communication with another modem has been established. This configuration has to be stored in the modem. Since the necessary commands to achieve this behavior vary depending on the type of modem, no exact instructions can be given here and you should check your modem's manual.

### 7.3.4 Configuring the terminal-program

You can create a configuration-files for 'TERMINAL' and 'HYPER TERMINAL' setting the communication-parameters following the values:

- 9600 Bd
- 8-bit word-length
- No parity
- 1 Stop-bit
- All transmissions must be ended with a <CR><LF>-pair.

### 7.3.5 Using the 'Service-Interface'

After you have connected the Hirolink to the PC, you have to switch the Hirolink off and on once. After that you will see the following string appear on the PC:

```
ATE0X0
```

By issuing this string the Hirolink tries to communicate with a modem that might be connected. This string is issued by the Hirolink in an interval of app. 10 seconds. If you are connected to the Hirolink directly, you can interrupt this querying mechanism by sending a <CR><LF> (= <ENTER>)-pair to the Hirolink. The Hirolink will then respond with the following string:

```
NO MODEM CONNECTED
```

After that the service-interface is ready for operation. The available command can be used in exactly the same way if a modem is connected. The only difference is that you have to call the Hirolink before you can perform any commands.

Pressing <ENTER> again will return the Hirolinks type and version. For example:

```
HLI for Modbus, V 2.80
```

In general each command you can send to the Hirolink starts with 'Q' or 'q' (the commands are not case-sensitive) and one or more characters identifying the command.

Since the amount of supported commands and their functionality is likely to be increased over time, the available commands are not described herein. Instead the Hirolink provides 'Online'-help-information, which can be accessed either by sending the command 'Q?', which provides an overview of the available commands or by sending 'QX?' (where 'X' is a placeholder for the selected command), which provides detailed help-information for the selected command.

If the Hirolink hasn't received any valid command for a time longer than app. 2 minutes, it will switch back to the modem-querying-mechanism described above.



## 8. Hardware-Reference

The following chapter contains detailed descriptions of the needed hardware-components, like the Hiolink, the various interface-cards, the cable connections and so on.

### 8.1 4-connector Hiolink

As mentioned before, there are two different layouts of the 4-connector Hiolink-front-panel as shown in the following illustrations:

Previous layout of 4-connector Hiolink-front-panel:

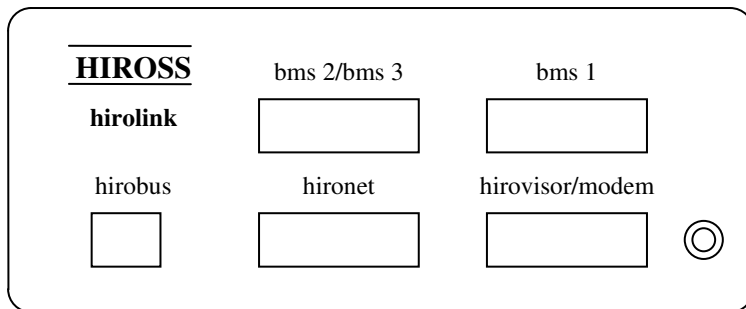

Current layout of 4-connector Hiolink-front-panel:

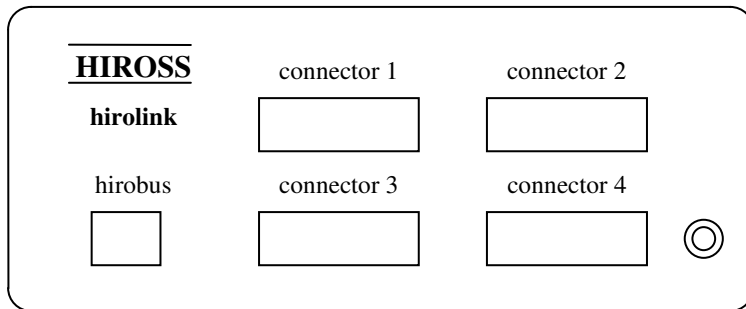

Layout of 4-connector Hiolink-back-panel:

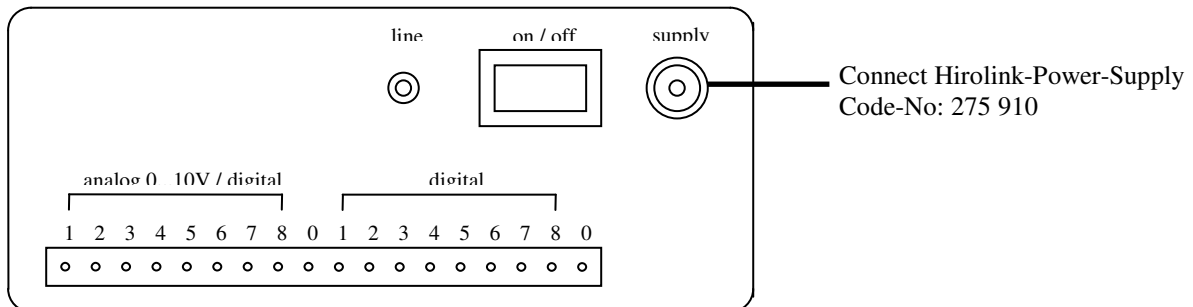

Hiolink: Code-No: 275 140  
 Size: 157 x 62 x 260 mm (w x h x d)  
 Supply voltage: 10 - 20 V AC or DC

Layout of Hirolink Classic -back-panel:

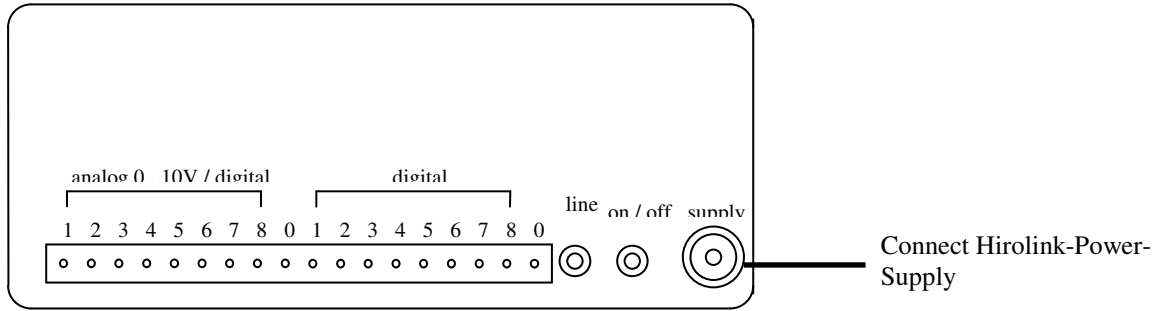

Hirolink: Code-No: 275 140  
 Size: 157 x 62 x 260 mm (w x h x d)  
 Supply voltage: 10 - 20 V AC or DC

## 8.2 Hirolink-Interface-Card-Sockets

The Hirolink provides 4 different sockets to insert interface-cards. The interface-card provides the connection between the connector on the outside of the Hirolink and the internal hardware. The following illustration shows which socket connects to which connector on the outside of the Hirolink. This connection-scheme is valid for both layouts of the Hirolink front-panel:

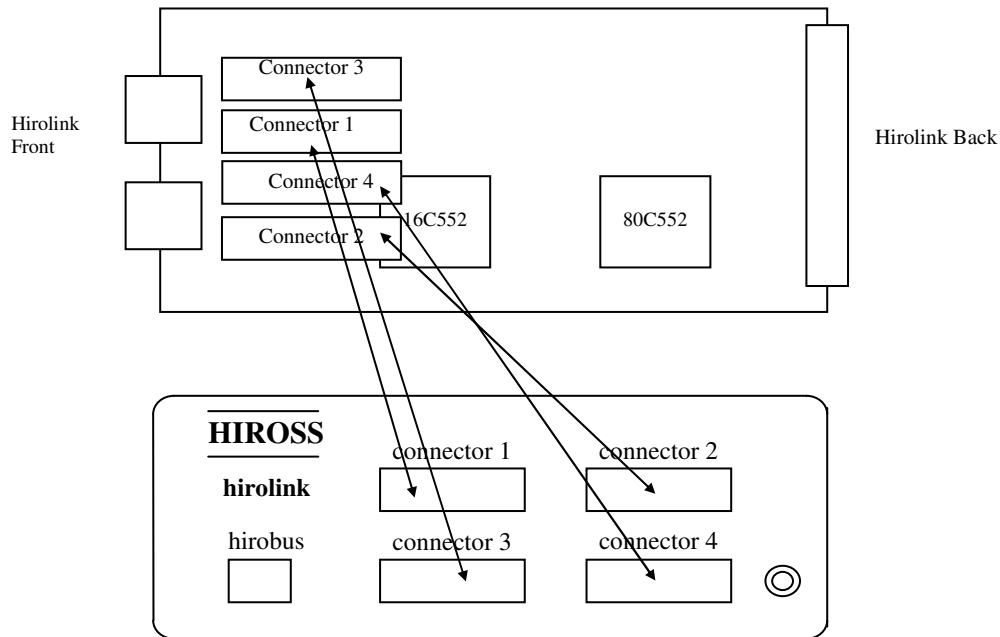

### 8.3 Hirolink-Interface-Cards (only for the 4-connector Hirolink)

#### 8.3.1 RS422/485-Interface-Card

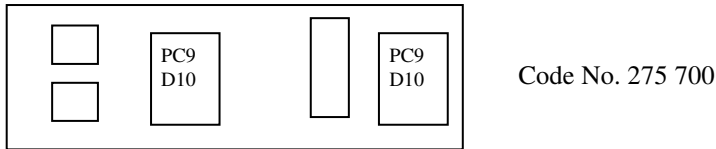

Inserting a RS422/485-interface-card into one of the sockets in the Hirolink results in the following pinning on the corresponding connector:

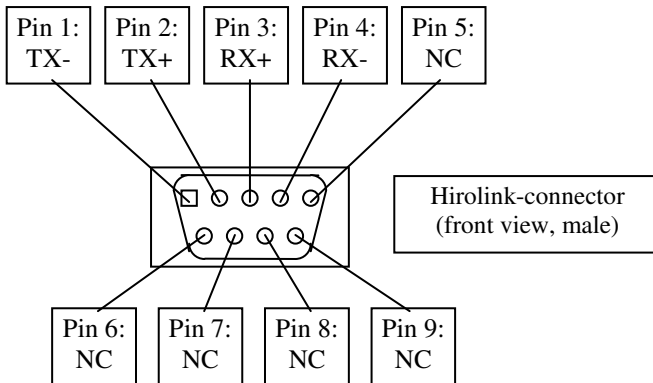

#### 8.3.2 RS232-Interface-Card

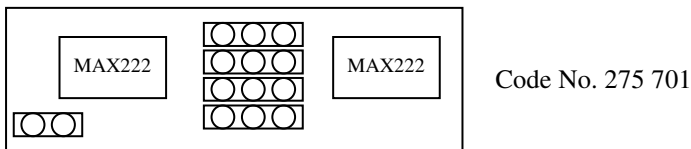

Inserting a RS232-interface-card into one of the sockets in the Hirolink results in the following pinning on the corresponding connector:

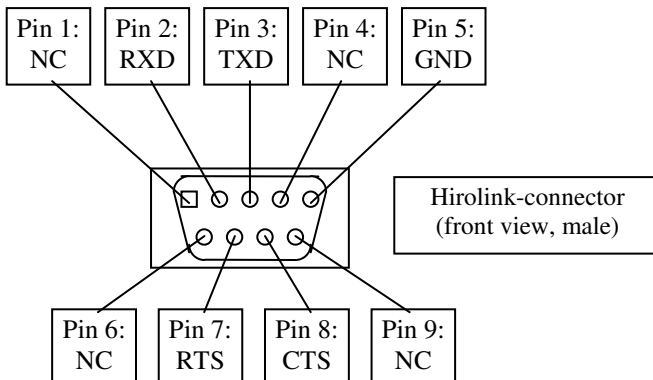

## 8.4 Hiromatic-Interface-Cards

### 8.4.1 Standard-RS422-Interface-Card

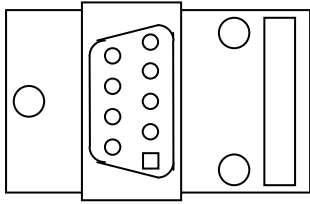

Code No. 482 992

Connector-pinning:

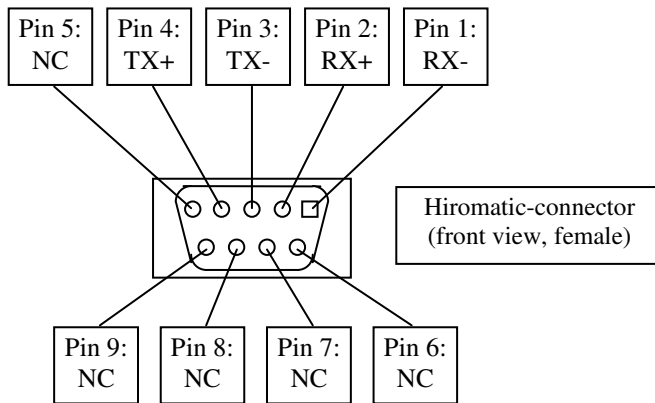

### 8.4.2 Optocoupled-RS422-Interface-Card

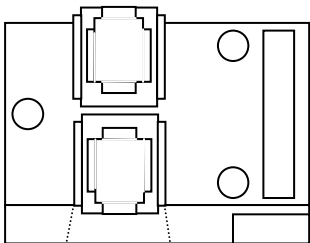

Code No. 275 631

Connector-pinning:

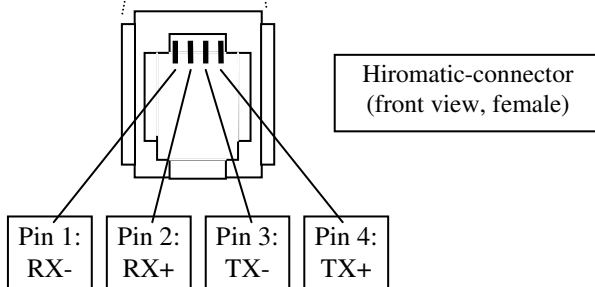

## 8.5 Connection between Hirolink and Hiromatics

### 8.5.1 RS422-Connection

RS422-connection using 'Standard RS422-interface-cards':

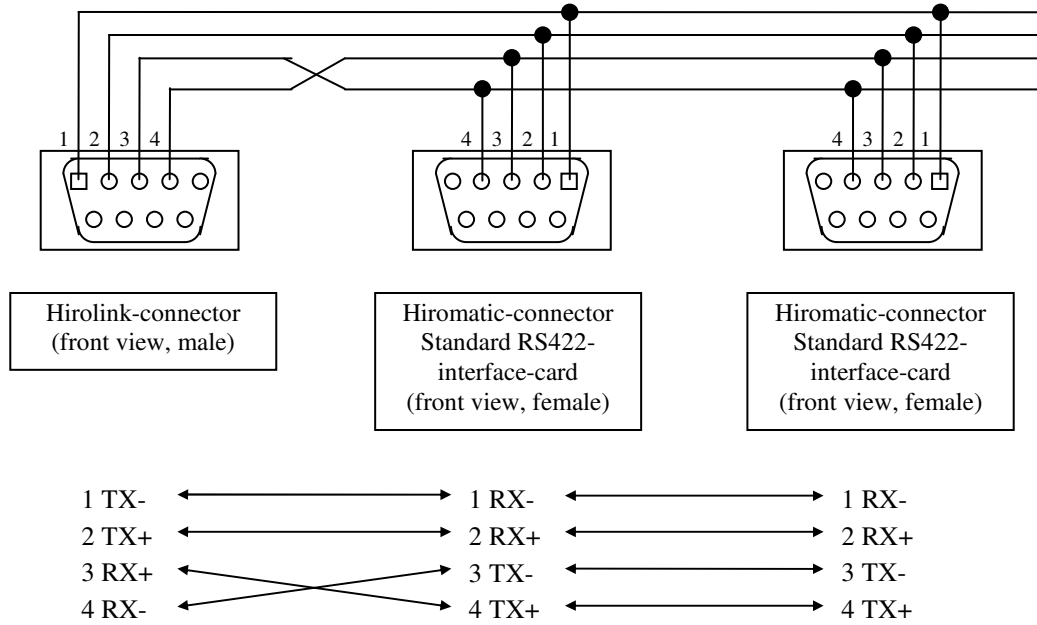

RS422-connection using 'Opto-coupled RS422-interface-cards':

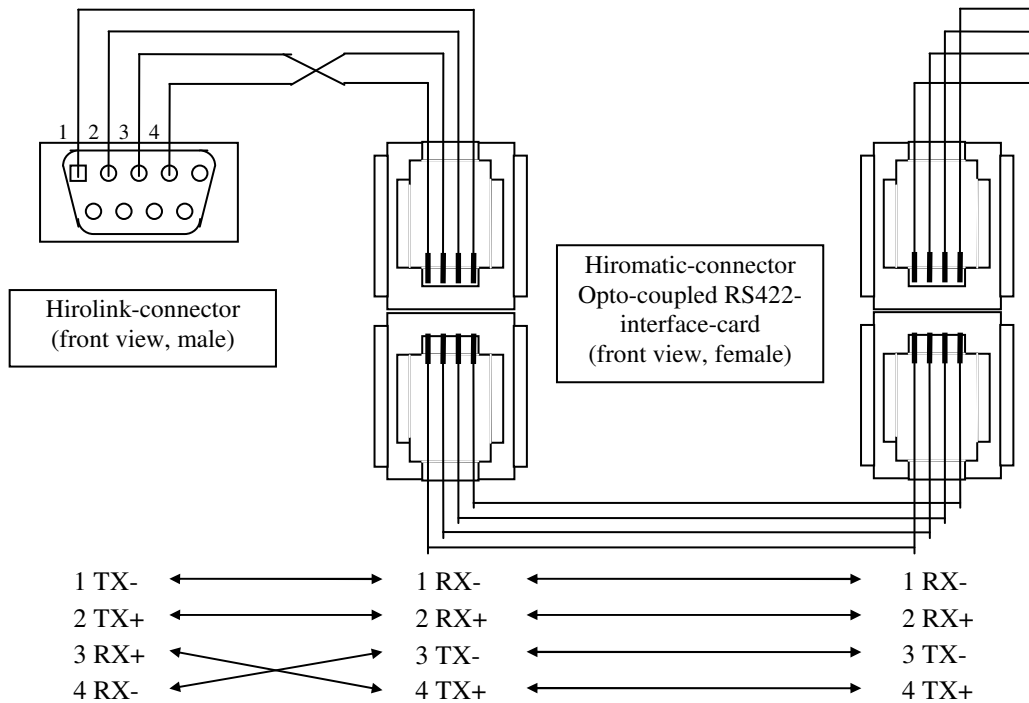

### 8.5.2 RS485-Connection

RS485-connection using 'Standard RS422-interface-cards':

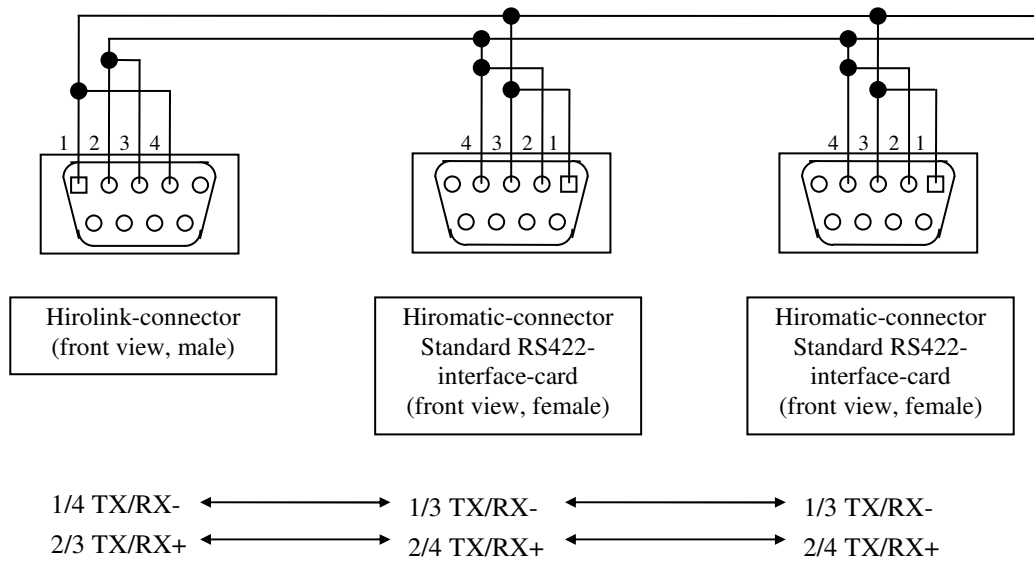

RS485-connection using 'Opto-coupled RS422-interface-cards':

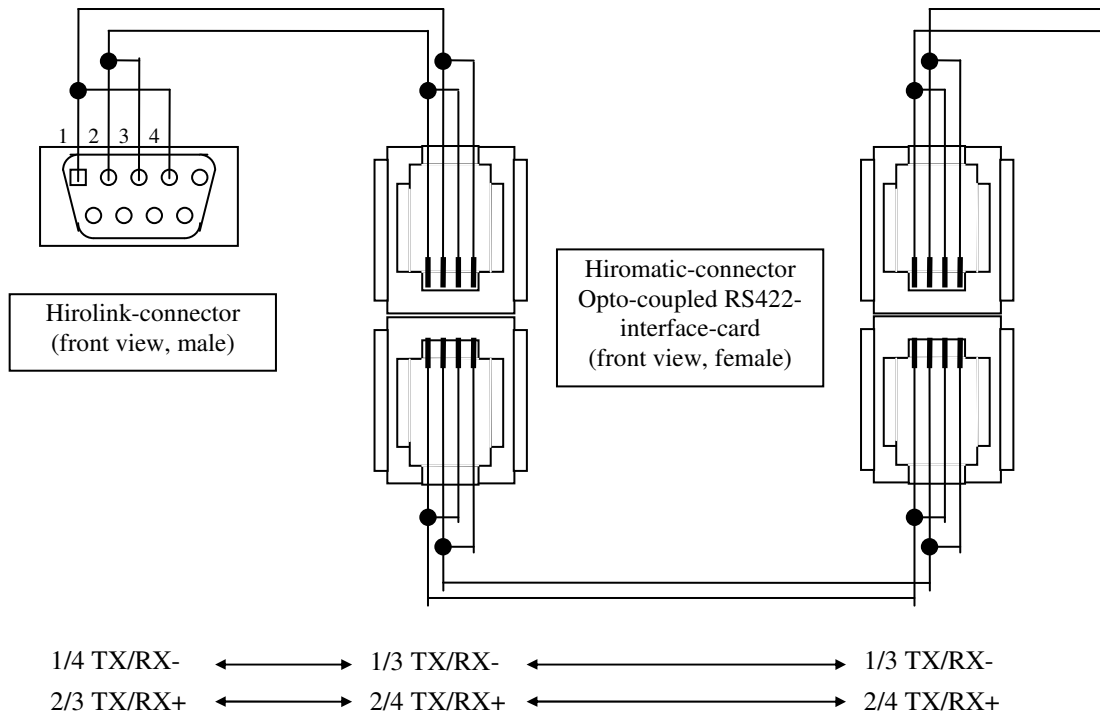

## 8.6 Standard PC-COM-Port-Pinning

### 8.6.1 Standard 9-pin RS232-COM-Port

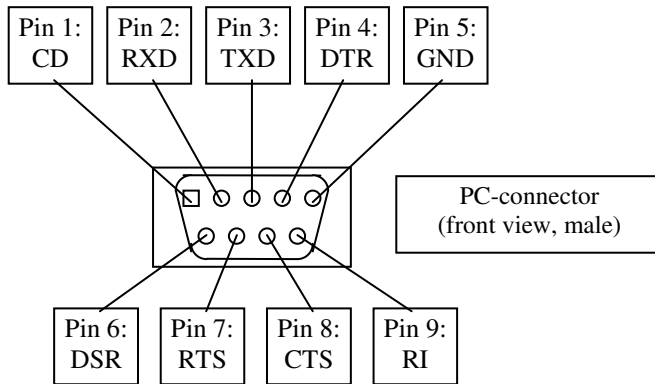

### 8.6.2 Standard 25-pin RS232-COM-Port

The following illustration names only those pins that are commonly used. The use of most of the pins named NC (Not connected) has been defined by the EIA, but they are usually not used:

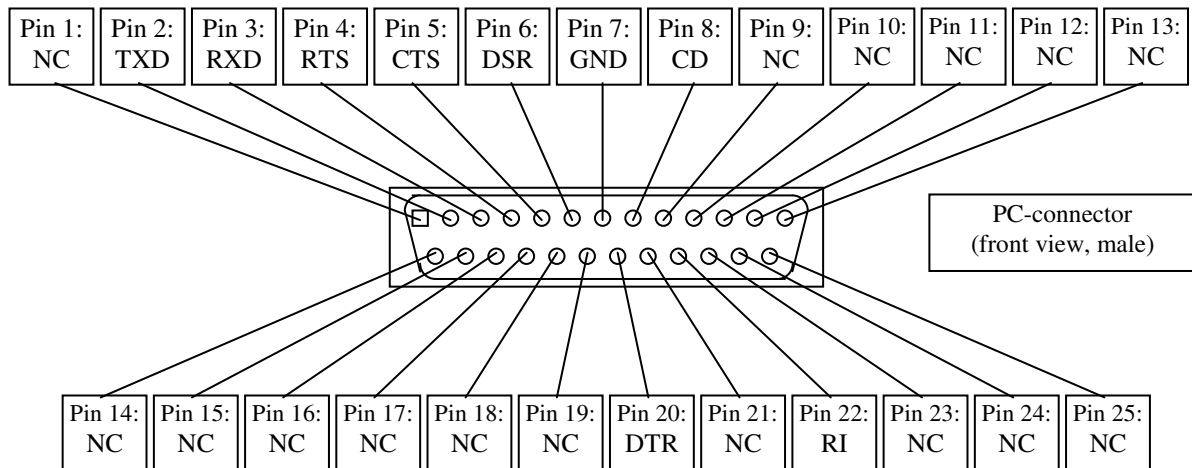

## Appendix A: Hiromatic-Types

This appendix lists all Hiromatic-types and defines which controllers they work with, if they can work in a network and if so, the maximum number of controllers that can work together:

<b>Hiromatic-Type</b>	<b>Controller</b>	<b>Networking-System</b>	<b>Maximum number of controllers</b>
<b>CAM</b>	Macroface	YES	16
<b>Compact Custom</b>	Modules	NO	-
<b>Dryer</b>	Modules	NO	-
<b>Energy Partner</b>	Macroface	YES	8
<b>Energy Partner Small</b>	Macroface	YES	8
<b>CPU Chiller</b>	Macroface	YES	8
<b>Advanced Graphic</b>	Macroface	NO	-
<b>Compact Graphic</b>	Modules	NO	-
<b>Hiflex</b>	Microface	YES	16
<b>Hiwall</b>	Microface	YES	16
<b>OENB</b>	Microface	YES	16
<b>Superchiller/Hichill</b>	Macroface	YES	8
<b>SIP</b>	Modules	NO	-
<b>Telecool Compact</b>	Macroface	YES	8
<b>Chiller</b>	Microface	YES	8
<b>Telecom Italia</b>	Microface	YES	8
<b>Superchiller 2000</b>	Microface	YES	8
<b>Matrix</b>	Microface	YES	8
<b>Hiross HPM</b>	iCOM	YES	24



**Appendix B: Compatibility-List**

This appendix lists all Hiromatic-types and their software-versions to which this software is compatible.

This column 'EPROM-Label' lists the abbreviations that are used for the various Hiromatic-types. The eproms that are inserted in the Hiromatic and Macroface or Microface (depending on your type of air-conditioner) must be labeled accordingly.

For example the eproms in a CAM-unit should be labeled GIC264 and MIC264, if the software-version is 2.64.

<b>Hiromatic-Type</b>	<b>EPROM-Label</b>	<b>Version</b>	<b>Date</b>
<b>CAM</b>	GIC + MIC	2.60	09/05/1997
		2.61	16/07/1997
		2.62	16/08/1997
		2.63	16/10/1997
		2.64	31/10/1997
<b>Compact Custom</b>	CWX	2.60	01/04/1996
		2.61	22/04/1996
		2.62	25/06/1996
		2.63	29/10/1996
		2.64	07/02/1997
		2.65	22/07/1997
<b>Dryer</b>	DRY	2.49B6	04/08/1995
		2.49B7	25/07/1995
		2.49B8	10/04/1996
		2.49B9	21/11/1996
		2.50	30/03/1998
<b>Energy Partner</b>	GPT + MPT	2.49	25/01/1995
		2.49B1	09/08/1995
<b>Energy Partner Small</b>	GPS + MPS	2.51	02/11/1995
		2.52	28/02/1996
		2.55	27/03/1996
		2.56	17/06/1996
		2.57	01/08/1996
<b>CPU Chiller</b>	GGS + MGS	2.49	25/01/1995
		2.49B1	17/03/1995
		2.49B2	09/08/1995
<b>Advanced Graphic</b>	GTF + MTF	2.60	01/04/1996
		2.61	25/06/1996
		2.62	28/10/1996
<b>Compact Graphic</b>	GWX	2.60	01.04.1996
		2.60E	12.06.1996
		2.61	25.06.1996
		2.61E	25.06.1996
		2.62	25.11.1996
		2.62PC	06.12.1996
<b>Hiflex</b>	WXG + WXM	1.15	28/10/1996
		1.20	22/01/1997
		1.39	27/05/1997
		1.41.002	28/07/1997

Hirolink for Modbus V 3.00 - General Documentation

		1.42	07/10/1997
		1.60.XXX	----
<b>Hiwall</b>	HWG + HWM	1.12	21/02/1997
		1.20	09/07/1997
<b>OENB</b>	VAG + VAM	1.00.011	17/12/1996
<b>Superchiller/Hichill</b>	GSB + MSB	2.50	10/08/1995
	or	2.51	21/10/1995
	GSH + MSH	2.52	20/11/1995
		2.55	21/03/1996
		2.56	25/06/1996
		2.57	18/02/1997
		2.58	07/03/1997
<b>SIP</b>	SIP	2.49	17/02/1995
		2.49A	24/02/1995
		2.49E	22/06/1995
		2.50E	13/03/1996
		2.51E	30/10/1996
<b>Telecool Compact Chiller</b>	GTC + MTC	2.50	20/12/1995
	CHG + CHM	1.02	17/06/1998
<b>Telecom Italia Superchiller 2000</b>	TIG + TIM	1.01.011	06/08/1999
<b>Matrix</b>	SCG + SCM	1.01.007	21/09/1999
<b>CAM / HIVAR</b>	SCG + SCM	1.02.005	---
<b>Hiross HPM</b>	HVM	1.00.0xx	xx
	EV	1.60.0xx	02/11/2006

**NOTE**

The software-date on Hiromatic-types 'Hiflex', 'Hiwall', 'OENB', 'Chiller', 'Telecom Italia' and 'Superchiller 2000' is displayed in the format 'mm/dd/yy' on the Hiromatic itself and not in the format 'dd/mm/yy' as written in the list above.

## **Appendix C: Software-Changes**

This appendix contains all changes that have been applied to this software up to the current version:

### 1. Changes from V 0.12 to V 0.13

- RTS/CTS-Management has been implemented for the RS232-Connector.
- Changes within Hiromatic-type 'Compact Graphic':
  - Holding registers for working-hours-sub-counters have been removed
  - New holding registers #39 to #51 have been introduced
  - New input-registers #17 to #21 have been introduced
- Changes within Hiromatic-type 'Advanced Graphic':
  - Coils #65 to #72 have been removed (these coils were not used).
  - Coil 'Alarm acknowledge for Hirolink' has been moved from #73 to #65
  - Holding register #26 (not used) has been removed
  - Holding registers for working-hours-sub-counters have been removed
  - New holding registers #59 to #69 have been introduced
  - New input-registers #28 to #33 have been introduced
- Changes within Hiromatic-type 'Advanced Compact':
  - Coils #57 to #64 have been removed (these coils were not used).
  - Coil 'Alarm acknowledge for Hirolink' has been moved from #65 to #57
  - Holding register #26 (not used) has been removed
  - New holding registers #38 to #48 have been introduced
  - New input-registers #30 to #33 have been introduced
- Changes within Hiromatic-type 'Superchiller/Hichill':
  - Holding register #2 to #6 have been removed
  - Input-registers #131 to #146 have been removed
- Changes within Hiromatic-type 'CAM':
  - New holding register #4 to #131 have been introduced
  - Input-registers #131 to #146 have been removed
- New Hiromatic-Software-type 'Dryer' has been introduced

### 2. Changes from V 0.13 to V 0.14

- Implementation of Hiromatic-type 'EPS'.
- Implementation of Hiromatic-type 'PTT'.

### 3. Changes from V 0.14 to V 0.15

- Implementation of Hiromatic- type 'GS'.
- Implementation of Hiromatic- type 'SIP'.

### 4. Changes from V 0.15 to V 2.00

- Error-correction in SIP-Implementation
- Error-correction: It wasn't possible to read items with item-ids higher than 255
- Implementation of Two-Color-LED

### 5. Changes from V 2.00 to V 2.01

- Implementation of RS485-connection to the Modbus-BMS

### 6. Changes from V 2.01 to V 2.02

- Faster updates for changed values implemented

### 7. Changes from V 2.02 to V 2.03

- Error-corrections in item-tables

### 8. Changes from V 2.03 to V 2.49

- Error-corrections in item-tables
- Implementation of alarm-type-byte
- New holding register #1 has been introduced (alarm acknowledge)
- Implementation of Hiromatic -type 'TC'
- Changes within Hiromatic-type 'Compact Custom':
  - Coils #28 and #29 have been removed.
  - New holding registers #27 to #29 have been introduced.
  - New Input register #18 has been introduced.
- Changes within Hiromatic-type 'Compact Graphic':
  - Coils #28 and #29 have been removed .
  - New holding registers #52 to #54 have been introduced.
  - New Input register #23 has been introduced.
- Changes within Hiromatic-type 'Dryer':
  - New holding register #2 has been introduced.

## 9. Changes from V 2.49 to V 2.60

- Error-corrections in item-tables
- Implementation of CAM 2.49
- Version name of MDE changed to CDE
- Update of 'Advanced Graphic' and 'Compact Graphic'
- Changes within Hiromatic-type 'Compact Graphic':
  - Coils #28, #29 and #30 have been removed .
  - New holding registers #14, #15, #20 and #21 have been introduced.
  - Changes of the range from some Items
  - New alarms appended on the alarm list

## 10. Changes from V 2.60 to V 2.61

- Error-correction in RS485-communication

## 11. Changes from V 2.61 to V 2.62

- Error-correction in RS485-communication
- Drivers are re-initialized after 30s of no communication to the BMS

## 12. Changes from V 2.62 to V 2.63

- Error-corrections in item-tables
- Implementation of 'Chinese Compact Graphic' 2.28

## 13. Changes from V 2.63 to V 2.64

- Implementation of OENB 1.00
- Implementation of 'Chinese Advanced Graphic' 2.54

## 14. Changes from V 2.64 to V 2.65

- Implementation of Hiflex 1.15
- Implementation of Hiwall 1.00
- Changes in item-table of OENB 1.00

## 15. Changes from V 2.65 to V 2.66

- Implementation of Hiflex 1.20
- Implementation of Hiwall 1.10
- Implementation of Hiwall 1.11

## 16. Changes from V 2.66 to V 2.67

- Implementation of Hiflex 1.30

## 17. Changes from V 2.67 to V 2.68

- Implementation of Hiflex 1.31

## 18. Changes from V 2.68 to V 2.69

- Error-correction in RS485-communication

## 19. Changes from V 2.69 to V 2.70

- Implementation of Hiflex 1.32
- Implementation of Hiwall 1.12

## 20. Changes from V 2.69 to V 2.71

- Implementation of Hiflex 1.36

## 21. Changes from V 2.71 to V 2.72

- Implementation of Hiflex 1.41
- In previous versions the red LED was only switched on, when a Hiromatic was connected to the queried address. Now the red LED is switched on in any case, when a valid transmission is received.

## 22. Changes from V 2.72 to V 2.73

- Correction in the implementation of Hiflex 1.41

## 23. Changes from V 2.73 to V 2.74

- Correction in the implementation of Hiromatic-type EPS:  
The implementation of V 2.50 was incorrect, so it was replaced with the implementation of V 2.51+.

## 24. Changes from V 2.74 to V 2.75

- Improvement of the communication with the Hiromatics.
- Correction in the implementation of Hiromatic-type 'Superchiller/Hichill':  
The transmission of the input-registers 'Outlet temperature (MF 1-8)' was corrected.
- Correction in the implementation of Hiromatic-type 'Dryer':  
The transmission of the input-status, holding- and input-registers was corrected.

## 25. Changes from V 2.75 to V 2.76

- Implementation of Hiflex V 1.52
- Implementation of Compact Custom Units V 2.67

## 26. Changes from V 2.76 to V 2.80

- A new way of handling the 'Status Report Acknowledge' was implemented.
- The service-interface was extended.
- Implementation of Chiller V 1.02

## 27. Changes from V 2.80 to V 2.81

- Implementation of Telecom Italia V 1.01
- Implementation of Hiflex V 1.60
- Implementation of Superchiller 2000 V 1.01
- Correction in the implementation of Hiromatic-version 'Chiller V 1.02'. The following datapoints weren't transmitted correctly under all circumstances:

Holding registers 42-57: 'Inlet Temperature Setpoint 1 (CTRL 1 - 16)'

Holding registers 314-329: 'Compressor High Pressure Warning at (CTRL 1 - 16)'

Holding registers 458-473: 'Autorestart Delay (CTRL 1 - 16)'

Holding registers 474-489: 'Teamwork Enable (CTRL 1 - 16)'

Input registers 89-104: 'Actual Temperature Setpoint (CTRL 1 - 16)'

Input registers 105-120: 'Inlet Temperature (CTRL 1 - 16)'

- Implementation of simultaneous communication with Hiromatics using 12 - and 11,0592 MHz-crystals.

## 28. Changes from V 2.81 to V 2.82

- Correction in the implementation of Hiromatic-version 'Superchiller 2000 V 1.01'.

## 29. Changes from V 2.82 to V 2.83

- Correction in the implementation of Hiromatic-version 'Telecom Italia V 1.01'.
- Correction of a bug when Hiromatics with the lowest and highest possible unit-ID are connected.
- The limitation of the highest possible unit-ID to 24 has been removed. Now it's possible to connect Hiromatics with unit-IDs up to 99 although the total number of connected Hiromatics must still not exceed 24.

## 30. Changes from V 2.83 to V 2.84

- Additions to the implementation of Hiromatic-version 'Superchiller 2000 V 1.01'.

### 31. Changes from V 2.84 to V 2.85

- Implementation of 'Event registers' (i.e. possibility to read the current state of each event) for WXG – 'Hiromatic for Microface' applications.
- Correction in the implementation of all 'Dryer'-Hiromatic-versions. The bug present in previous versions of the Hirolink made it impossible to communicate with Hiromatic-versions of this type properly.

### 32. Changes from V 2.85 to V 2.86

- Implementation of 'Event registers' (i.e. possibility to read the current state of each event) for Superchiller 2000 and Chiller applications.

### 33. Changes from V 2.86 to V 2.87

- The alarm management has been improved to permit the a faster upgrade of new alarm mapping table, introduced into the previous version (HLMB285 and HLMB286).

### 34. Changes from V 2.87 to V 2.88

- Multiple Writing corrected mistake corrected.
- Visibility of the Ambient temperature for EVG and E1G applications.

### 35. Changes from V 2.88 to V 2.89

- It has is released for the correction of SW mistake that happened when the BMS generated some writing in the Holding Registers and Hirolink could happen to report the same events multiple times.

### 36. Changes from V 2.89 to V 2.90

- Implementation of the Matrix units.

### 37. Changes from V 2.90 to V 2.91

- Additional datapoints for Matrix units implemented.
- CAM / HIVAR (Microface) units implemented

## **Appendix D: Document-Changes**

This appendix contains all changes that have been applied to this document up to the current version:

### 1. Changes from V 1.00 to V 1.01

The complete documentation was restructured and the following chapters were added:

Chapter 2. Overview  
Chapter 3. Serial Communication Basics  
Chapter 4. The Modbus-Protocol  
Chapter 5. Hiromatic-specific Topics  
Chapter 6. Installation Procedure  
Chapter 7. Testing the installation



Chapter 8. 'Hardware reference' is more or less the same as chapter 2 'Hardware Description' from the V 1.00 of this manual.

## 2. Changes from V 1.01 to V 1.02

- The Hirolink-version-number was updated from V 2.74 to V 2.75.
- The Dryer V 2.50 was added to the compatibility-list.
- The appendix Appendix C: 'Software-Changes' was extended.

## 3. Changes from V 1.02 to V 1.03

- The Hirolink-version-number was updated from V 2.75 to V 2.76.
- The appendix Appendix B: 'Introduction' was extended.
- The appendix Appendix C: 'Software-Changes' was extended.

## 4. Changes from V 1.03 to V 1.04

- The Hirolink-version-number was updated from V 2.76 to V 2.80.
- A description of the new way of handling the 'Status Report Acknowledge' was included in chapter 5.4 'The Status-Report' and chapter 0 'Preparing the Hirolink'.
- The description of the service-interface in chapter 7.3.5 'Using the 'Service-Interface' was changed.

## 5. Changes from V 1.04 to V 1.05

- The description of pin 4 in chapter 8.3.1 'RS422/485-Interface-Card' was corrected from 'RX+' to 'RX-'.

## 6. Changes from V 1.05 to V 1.06

- The Hirolink-version-number was updated from V 2.80 to V 2.81.
- The compatibility-lists were extended with Telecom Italia V 1.01, Hiflex V 1.60 and Superchiller 2000 V 1.01.
- The sections '5.4 The Status-Report' and '0 Preparing the Hirolink' were upgraded to include information about the new jumper-setting 'Status Report Acknowledge' introduced in V 2.80.
- The section '6.2 Preparing the Hiromatic' was upgraded to include information about the new possibility to communicate with Hiromatics using either a 12 MHz- or a 11,0592 MHz-crystal.
- The section 'Appendix C:27 Changes from V 2.80 to V 2.81' was added.

## 7. Changes from V 1.06 to V 1.07

- The section Appendix C:28 'Changes from V 2.81 to V 2.82' was added.

## 8. Changes from V 1.07 to V 1.08

- Due to a software-upgrade, which removed the limitation of the highest possible Hiromatic-ID to 24, all references regarding this topic were removed.
- Mistakes in the pinning- and connection illustrations where female 9-pin-connectors are used were corrected.
- The section Appendix C:29 'Changes from V 2.82 to V 2.83' was added.

## 9. Changes from V 1.08 to V 1.09

- The section Appendix C:30 'Changes from V 2.83 to V 2.84' was added.

## 10. Changes from V 1.09 to V 1.10

- The section Appendix C:31 'Changes from V 2.84 to V 2.85' was added.
- General upgrade of images and text in order to provide configuration-information for the new Hirolink Classic.
- Substitution of the text '24 Hiromatics' with '24 Air conditioners'
- The first illustration in section 2 'Overview' was showing the Hironet connection in a wrong way. A Hironet connection should always be build up in a chain-like manner and not in a star-like manner as it was indicated in this illustration.
- The following sentence was added to the point 'Microface' in the first part of the section 5.2 'Networking Systems': "The maximum number of Microfaces that can work with each other is 16, but when the Hiromatic is connected to Hirolink the maximum number of them is 8."
- A square (as opposed to a circle) is now used in general to indicate pin #1 in all wiring- and connector-diagrams.

## 11. Changes from V 1.10 to V 1.11

- The section Appendix C:32 'Changes from V 2.85 to V 2.86' was added.

## 12. Changes from V 1.11 to V 1.12

- The section 8.6.2Appendix C:33 Changes from V 2.86 to V 2.87was added.

## 13. Changes from V 1.11 to V 1.13

- The section Changes from V 2.87 to V 2.88 was added.

## 14. Changes from V 1.13 to V 1.14

- Description of Hiromatic E was added.

## 15. Changes from V 1.14 to V 1.15

- Only version number (2.91) changed.

## 16. Changes from V 1.15 to V 1.16

- In this version the MODBUS command 16 has been implemented, version number (2.92) changed.

## 17. Changes from V 1.16 to V 1.17

- SysTempDi and SysHumiDi have been added (see NT288-E7ME7S-E7E) into the Input Register, version number (2.93) changed.

## 18. Changes from V 1.17 to V 1.18

- Only version number (2.94) changed.

#### 19. Changes from V 1.18 to V 1.19

- Powerface compatibility added, version number (2.97) changed.

#### 20. Changes from V 1.19 to V 1.20

- IMM101030 compatibility added version number (2.99) changed.

#### 21. Changes from V 1.20 to V 1.21

- iCOM compatibility added, version number (2.99) changed.

#### 22. Changes from V 1.21 to V 1.22

- DGP-box (DIM) compatibility added, version number (3.00) changed.
- RACK (RKE) compatibility added, version number (3.00) changed.
- XDFN (XDE) compatibility added, version number (3.00) changed.

#### 23. Changes from V 1.22 to V 1.23

- iCOM AAM compatibility added, version number (3.00) changed.

## **Connectivity**

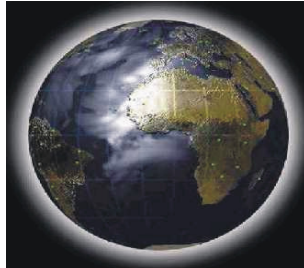

*the evolution*

## **Hirolink for Modbus**

**(01) Items for CCAC (CWX) (Compact Custom).doc**

**English**

04/11/03 Release 1.02E

**1. INTRODUCTION CCAC (CWX) (COMPACT CUSTOM) ..... 3**

**2. COMPATIBILITY-LIST ..... 3**

**3. ITEMS FOR CCAC (CWX) (COMPACT CUSTOM) ..... 4**

    3.1 COILS..... 4

    3.2 INPUT-STATUS..... 5

    3.3 HOLDING REGISTER..... 6

    3.4 INPUT-REGISTER ..... 7

    3.5 EVENTS..... 8

**4. DOCUMENT-CHANGES ..... 9**

## 1. Introduction CCAC (CWX) (Compact Custom)

This document contains a description of all data-points that are available via the 'Hirolink for Modbus' from this type of air-conditioner.

### **IMPORTANT:**

It is vital to the correct integration of the Hirolink into a Modbus-network, that you have read and understood the topics described in the document 'Hirolink for Modbus V X.XX - General Documentation' (X.XX is a placeholder for the current version of the Hirolink). So, if you haven't read this document until now, read it first.

## 2. Compatibility-List

Before connecting a Hiromatic to the Modbus-Hirolink you must check, if the Hiromatic-software-version is compatible with this version of the Hirolink.

You can do this by checking the labels on the eprom, which is inserted into the Hiromatic. This eprom must be called CWX + Version-Number (e.g. CWX260).

To make sure that the label on the eproms is correct, you should also check the version-information, that the Hiromatic displays shortly after start-up. This information should look similar to the following illustration:

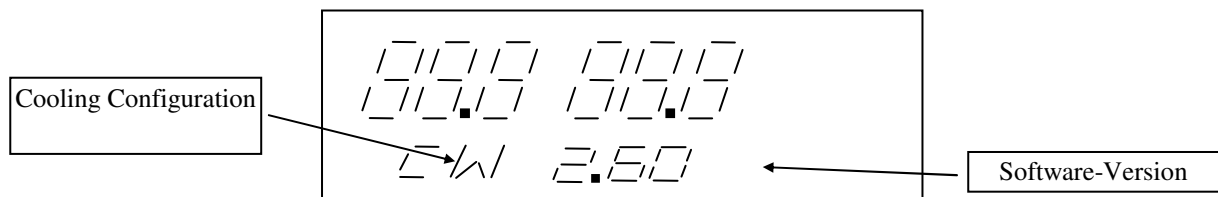

The important information in this window is only the software-version. Make sure that the software-version installed in your installation matches one of the compatible versions listed below:

<b>Version</b>	<b>Date</b>
2.60	01.04.1996
2.61	22.04.1996
2.62	25.06.1996
2.63	29.10.1996
2.64	07.02.1997
2.65	22.07.1997
2.67	03.09.1998

### 3. Items for CCAC (CWX) (Compact Custom)

According to the Modbus-protocol-specifications the values and parameters provided by the Hiromatic are represented in 4 groups:

- Coils: Used for changeable, digital values
- Inputs: Used for not changeable, digital values
- Holding Registers: Used for changeable, analog values
- Input Registers: Used for not changeable, analog values

This Hirolink can be compatible with more than one version of this Hiromatic-type and it is possible that there have been extensions in the number of available items from one version to the next.

Therefore the column 'SW-Version' contained in the following lists provides information about the availability of each item depending on the Hiromatic-software-version. For example a entry like '2.60+' means, that this item is available from Hiromatics with software-version 2.60 and higher.

#### **IMPORTANT:**

The available data-points shown in the following chapters are numbered starting from 1, according to the Modbus-Protocol-Specification. Still some BMS start numbering the data-points from 0.

So, in case that the BMS you are using starts numbering from 0, you have to decrease the listed numbers by 1.

#### **3.1 Coils**

Coil #	Usage	SW-Version
1	Set system off (Command)	2.60+
2	Set system on (Command)	2.60+
3	Set manual on (Command)	2.60+
4	Set manual drain (Command)	2.60+
5	Set alarm acknowledge (Command)	2.60+
6	Set alarm reset (Command)	2.60+
7	Set standard-settings (Command)	2.60+
8	Not used	2.60+
9	EEAP-Sensor installed	2.60+
10	User input 1: 0..Warning,1..Alarm	2.60+
11	User input 1: sleep mode disable	2.60+
12	Not used	2.60+
13	Not used	2.60+
14	Cooling configuration CW	2.60+
15	Cooling configuration CW+SS	2.60+
16	Not used	2.60+
17	Not used	2.60+
18	Water leakage detector installed	2.60+
19	Not used	2.60+
20	Remote off installed	2.60+
21	Local on/off disabled	2.60+
22	Fan failure: 0..Warning,1..Alarm	2.60+
23	Temperature: 0.. °C,1..F	2.60+
24	Not used	2.60+
25	Dehumidification inverse	2.60+
26	Dehumidification enabled	2.60+
27	Pumpdown installed	2.60+
28	Not used	2.60+

29	Not used	2.60+
30	Humitemp-Sensor installed	2.60+
31	Not used	2.60+
32	Not used	2.60+
33	Status fans	2.60+
34	Status compressor / open valve	2.60+
35	Status pumpdown / close valve	2.60+
36	Status electrical heater 1	2.60+
37	Status humidifier boiler	2.60+
38	Status humidifier feed	2.60+
39	Status humidifier drain	2.60+
40	Status dehumidification	2.60+
41	Status electrical Heater 2	2.60+
42	Status manual humidifier drain	2.60+
43	Not used	2.60+
44	Not used	2.60+
45	Not used	2.60+
46	Not used	2.60+
47	Not used	2.60+
48	Not used	2.60+
49	Status-Report-Acknowledge	2.60+

**IMPORTANT:**

Read the document 'Hirolink for Modbus V X.XX - General Documentation' (X.XX is a placeholder for the current version of the Hirolink) for a description on how to use the coils marked with 'Command'.

**Status-Report-Acknowledge (Coil #49):**

Read the document 'Hirolink for Modbus V X.XX - General Documentation' (X.XX is a placeholder for the current version of the Hirolink) for a description on how to use this data-point.

**3.2 Input-Status**

Input-Status #	Usage	SW-Version
1	Alarm active	2.60+
2	Warning active	2.60+
3	Alarm acknowledge active	2.60+
4	Manual drain active	2.60+
5	Standard-settings active	2.60+
6	Not used	2.60+
7	Not used	2.60+
8	Not used	2.60+
9	Remote on/off	2.60+
10	High pressure compressor	2.60+
11	Low pressure compressor	2.60+
12	Clogged filters	2.60+
13	Heaters overheated	2.60+
14	User input	2.60+
15	Humidifier level	2.60+



### 3.3 Holding Register

Register #	Usage	Range; Unit	SW-Version
1	Status-Report-acknowledge	See description below	2.60+
2	Temperature-setpoint	175 - 300; [1/10 °C]	2.60+
3	Humidity-setpoint	350 - 750; [1/10 %RH]	2.60+
4	Integration factor	0->No integration, 5-15; [min]	2.60+
5	Temperature proportional band	5 - 50; [2/10 K]	2.60+
6	Humidity proportional band	5 - 20; [%RH]	2.60+
7	Humidity control	128 -> Proportional, 40 -> On/Off	2.60+
8	Dehumidification hysteresis	25 - 75; [%]	2.60+
9	Autorestart time	0->No autorestart, 1-60; [s]	2.60+
10	High temperature warning level	10 - 50; [°C]	2.60+
11	Low temperature warning level	0 - 30; [°C]	2.60+
12	High humidity warning level	30 - 99; [%RH]	2.60+
13	Low humidity warning level	10 - 70; [%RH]	2.60+
14	High temperature alarm level	10 - 50; [°C]	2.60+
15	Low temperature alarm level	0 - 30; [°C]	2.60+
16	High humidity alarm level	30 - 99; [%RH]	2.60+
17	Low humidity alarm level	10 - 70; [%RH]	2.60+
18	Low airflow warning level	0 - 100; [%]	2.60+
19	Low pressure alarm delay	0 - 5.; [min]	2.60+
20	Humidifier supply voltage	1 -> 240V, 2 -> 380V, 3 -> 460V, 4 -> 575V	2.60+
21	Humidifier model	1 -> 21L, 2 -> 51L, 3 -> 51H, 4 -> 93L, 5 -> 93H, 6 -> Ext	2.60+
22	Humidifier steam output	0 -> No humidification; 1 -> 30%, 2 -> 40%, 3 -> 50%, 4 -> 60%, 5 -> 70%, 6 -> 80%, 7 -> 90%, 8 -> 100 %	2.60+
23	Heating steps	2 - 3 (only if 2 el. heaters are installed)	2.60+
24	Valve running time	50 - 500; [s]	2.60+
25	Temperature-sensor-offset	-50 - 50; [1/10 K]	2.60+
26	Humidity-sensor-offset	-99 - 99; [%RH]	2.60+
27	Supply air setpoint	45-->No, 50 - 250; [1/10 °C]	2.60+
28	El. heater 1 configuration	0 -> NO, 1 -> YES, 2 -> High temperature warning	2.60+
29	El. heater 2 configuration	0 -> NO, 1 -> YES, 2 -> High temperature alarm	2.60+

#### Status-Report-Acknowledge (Holding Register #1):

Read the document 'Hirolink for Modbus V X.XX - General Documentation' (X.XX is a placeholder for the current version of the Hirolink) for a description on how to use this data-point.

### 3.4 Input-Register

Register #	Usage	Unit	SW-Version
1	Event-ID	See explanation below	2.60+
2	Not used		2.60+
3	Not used		2.60+
4	Not used		2.60+
5	Not used		2.60+
6	Event-Type	0 -> message, 1 -> warning, 2 -> alarm 3 -> reset	2.60+
7	System status	See explanation below	2.60+
8	Actual temperature	[1/10 °C]	2.60+
9	Actual humidity	[1/10 %RH]	2.60+
10	Actual temperature EEAP	[1/10 °C]	2.60+
11	Actual humidity EEAP	[1/10 %RH]	2.60+
12	Liquistat sensor	[1/100 V]	2.60+
13	Airflow rate sensor	[1/100 V]	2.60+
14	Humidifier current	[1/100 A]	2.60+
15	Chilled water ramp	[%]	2.60+
16	Super saver ramp	[%]	2.60+
17	Hot water ramp	[%]	2.60+
18	Sensor-Configuration	See explanation below	2.60+
19	Supply Air Temperature	[1/10 °C]	2.67+

#### Status-Report-Block (Input Register #1 - #6):

Read the document 'Hirolink for Modbus V X.XX - General Documentation' (X.XX is a placeholder for the current version of the Hirolink) for a description on how to use these data-points.

#### System Status (Input Register #7):

The values of this item correspond to the following system-states:

- 0..System off
- 1..System on
- 2..Manual on
- 3..Remote off
- 4..Remote on
- 5..Sleep mode on

#### Sensor Configuration (Input Register #18):

The values of this item correspond to the following configurations:

- 0..PTC only
- 1..Humitemp only
- 2..Humitemp + PTC
- 3..Humitemp + Hirosensor
- 4..Humitemp + Hirosensor + PTC

### 3.5 Events

#### **IMPORTANT:**

Read the document 'Hirolink for Modbus V X.XX - General Documentation' (X.XX is a placeholder for the current version of the Hirolink) for a detailed description on how to use these data-points.

In the following list you can see all Events and Event-IDs available for Compact Custom-units:

Event-ID	Event-Description	Event-Type	SW-Version
1	HIGH PRESSURE COMPRESSOR, check freon circuit + condenser	Alarm	2.60+
2	LOW PRESSURE COMPRESSOR, check freon circuit	Alarm	2.60+
3	EL. PROTECTION COMPRESSOR, check freon circuit + condenser	Alarm	2.60+
4	NOT USED		2.60+
5	NOT USED		2.60+
6	NOT USED		2.60+
7	NOT USED		2.60+
8	NOT USED		2.60+
9	NOT USED		2.60+
10	CHILLED WATER TEMP. TOO HIGH FOR SAFE OPERATION	Warning	2.60+
11	CHILLED WATER FLOW TOO LOW FOR SAFE OPERATION	Warning	2.60+
12	EL. HEATERS OVERHEATING, check fans and sensors	Warning	2.60+
13	LOSS OF AIR FLOW, check fans	Warning	2.60+
14	CLOGGED FILTERS, check air filters	Warning	2.60+
15	NOT USED		2.60+
16	WATER LEAKAGE DETECTION, check hydraulic circuit	Warning	2.60+
17	USER INPUT #1 TRIGGERED	Warning	2.60+
18	NOT USED		2.60+
19	NOT USED		2.60+
20	HUMIDIFIER FAILURE	Alarm	2.60+
21	HUMIDIFIER SHORT CIRCUIT, check el. circuit + cylinder	Alarm	2.60+
22	HUMIDIFIER HIGH CURRENT, check cylinder	Alarm	2.60+
23	HUMIDIFIER MAINS FAILURE, check electrical circuit	Alarm	2.60+
24	HUMIDIFIER WITHOUT WATER, check water supply	Warning	2.60+
25	HUMIDIFIER CYLINDER WORN, please replace	Warning	2.60+
26	NOT USED		2.60+
27	NOT USED		2.60+
28	NOT USED		2.60+
29	NOT USED		2.60+
30	HIGH ROOM TEMPERATURE	Warning	2.60+
31	LOW ROOM TEMPERATURE	Warning	2.60+
32	HIGH ROOM HUMIDITY	Warning	2.60+
33	LOW ROOM HUMIDITY	Warning	2.60+
34	HIGH ROOM TEMPERATURE SENSED BY EEAP	Alarm	2.60+
35	LOW ROOM TEMPERATURE SENSED BY EEAP	Alarm	2.60+
36	HIGH ROOM HUMIDITY SENSED BY EEAP	Alarm	2.60+
37	LOW ROOM HUMIDITY SENSED BY EEAP	Alarm	2.60+

38	NOT USED		2.60+
39	NOT USED		2.60+
40	NOT USED		2.60+
41	NOT USED		2.60+
42	NOT USED		2.60+
43	NOT USED		2.60+
44	NOT USED		2.60+
45	NOT USED		2.60+
46	NOT USED		2.60+
47	NOT USED		2.60+
48	NOT USED		2.60+
49	MANUAL MODE	Message	2.60+
50	POWER OFF	Message	2.60+
51	POWER RESTORED	Reset	2.60+
52	SYSTEM ON	Message	2.60+
53	SYSTEM OFF	Message	2.60+
54	REMOTE ON	Message	2.60+
55	REMOTE OFF	Message	2.60+
56	ALARM RESET	Reset	2.60+
57	ALARM ACKNOWLEDGED	Message	2.60+
58	SLEEP MODE ON	Message	2.60+
59	SLEEP MODE OFF	Message	2.60+
60	RAM ERROR, replace display board	Alarm	2.60+
61	EPROM ERROR, please replace eprom	Alarm	2.60+
62	EEPROM ERROR, replace display board	Alarm	2.60+
63	DISPLAY BOARD FAILURE, please replace	Alarm	2.60+
64	NOT USED	Alarm	2.60+
65	ROOM SENSOR FAILURE, please replace sensor	Alarm	2.60+
66	EEAP SENSOR FAILURE, please replace sensor	Alarm	2.60+
67	WATER PRESENCE SENSOR FAILURE, check wiring	Warning	2.60+
68	FILTER PRESSURE DROP SENSOR FAILURE	Warning	2.60+
69	PRINTING IMPOSSIBLE, check connections	Warning	2.60+
70	SENSOR CONFIGURATION RESTORED	Message	2.60+
71	HIROSENSOR FAILURE, please replace sensor	Alarm	2.60+
72	PTC-SENSOR FAILURE, please replace sensor	Alarm	2.60+
73	USER-SETTINGS RESTORED	Message	2.60+
100	UNIT CONNECTED	Message	2.60+
101	UNIT NOT CONNECTED	Message	2.60+

#### 4. Document-Changes

This appendix contains all changes that have been applied to this document up to the current version:

##### 1. Changes from V 1.00 to V 1.01

All descriptions regarding the 'Status-Report' have been moved to the document 'Hirolink for Modbus V X.XX - General Documentation' (X.XX is a placeholder for the current version of the Hirolink).

##### 2. Changes from V 1.01 to V 1.02

- The data-point 'Supply Air Temperature' is provided through the input register #19.

## Connectivity



*the evolution*

## Hirolink for Modbus

(02) Items for CCAC (GWX) (Compact Graphic).doc

English

04/11/03 Release 1.01E

<b>1.</b>	<b>INTRODUCTION CCAC (GWX) (COMPACT GRAPHIC)</b> .....	<b>3</b>
<b>2.</b>	<b>COMPATIBILITY-LIST</b> .....	<b>3</b>
<b>3.</b>	<b>ITEMS FOR CCAC (GWX) (COMPACT GRAPHIC)</b> .....	<b>4</b>
3.1	COILS .....	4
3.2	INPUT-STATUS .....	6
3.3	HOLDING REGISTER .....	6
3.4	INPUT-REGISTER .....	8
3.5	EVENTS .....	9
<b>4.</b>	<b>DOCUMENT-CHANGES</b> .....	<b>10</b>

# 1. Introduction CCAC (GWX) (Compact Graphic)

This document contains a description of all data-points that are available via the 'Hirolink for Modbus' from this type of air-conditioner.

## **IMPORTANT:**

It is vital to the correct integration of the Hirolink into a Modbus-network, that you have read and understood the topics described in the document 'Hirolink for Modbus V X.XX - General Documentation' (X.XX is a placeholder for the current version of the Hirolink). So, if you haven't read this document until now, read it first.

## 2. Compatibility-List

Before connecting a Hiromatic to the Modbus-Hirolink you must check, if the Hiromatic-software-version is compatible with this version of the Hirolink.

You can do this by checking the labels on the eprom, which is inserted into the Hiromatic. This eprom must be called GWX + Version-Number (e.g. GWX262).

To make sure that the label on the eproms is correct, you should also check the version-information, that the Hiromatic displays shortly after start-up. This information should look similar to the following illustration:

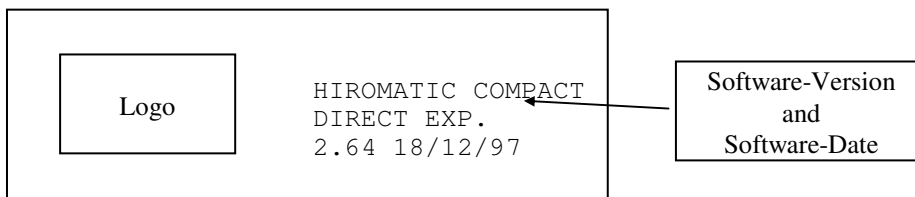

The important information in this window is only the software-version and the software-date. Make sure that the software-version installed in your installation matches one of the compatible versions listed below:

<b>Version</b>	<b>Date</b>
2.60	01.04.1996
2.60E	12.06.1996
2.61	25.06.1996
2.61E	25.06.1996
2.62	25.11.1996
2.62PC	06.12.1996
2.64	18.12.1997

### 3. Items for CCAC (GWX) (Compact Graphic)

According to the Modbus-protocol-specifications the values and parameters provided by the Hiromatic are represented in 4 groups:

- Coils: Used for changeable, digital values
- Inputs: Used for not changeable, digital values
- Holding Registers: Used for changeable, analog values
- Input Registers: Used for not changeable, analog values

This Hirolink can be compatible with more than one version of this Hiromatic-type and it is possible that there have been extensions in the number of available items from one version to the next.

Therefore the column 'SW-Version' contained in the following lists provides information about the availability of each item depending on the Hiromatic-software-version. For example a entry like '2.60+' means, that this item is available from Hiromatics with software-version 2.60 and higher.

#### **IMPORTANT:**

The available data-points shown in the following chapters are numbered starting from 1, according to the Modbus-Protocol-Specification. Still some BMS start numbering the data-points from 0. So, in case that the BMS you are using starts numbering from 0, you have to decrease the listed numbers by 1.

#### **3.1 Coils**

Coil #	Usage	SW-Version
1	Set system off (Command)	2.60+
2	Set system on (Command)	2.60+
3	Set manual on (Command)	2.60+
4	Set manual drain (Command)	2.60+
5	Set alarm acknowledge (Command)	2.60+
6	Set alarm reset (Command)	2.60+
7	Set standard-settings (Command)	2.60+
8	Not used	2.60+
9	EEAP-Sensor installed	2.60+
10	User input 1 (coils 10 and 11 are used together)	2.60+
11	00..Warning; 01..Alarm; 10..Sleep mode disable	2.60+
12	Not used	2.60+
13	Not used	2.60+
14	Cooling configuration: See description below	2.60+
15	Cooling configuration: See description below	2.60+
16	Cooling configuration: See description below	2.60+
17	Not used	2.60+
18	Water leakage detector installed	2.60+
19	Not used	2.60+
20	Remote off installed	2.60+
21	Local on/off disabled	2.60+
22	Fan failure: 0..Warning,1..Alarm	2.60+
23	Temperature: 0..°C,1..F	2.60+
24	Sleepmode restore	2.60+
25	Dehumidification inverse	2.60+
26	Dehumidification enabled	2.60+
27	Pumpdown installed	2.60+
28	Not used	2.60+
29	Not used	2.60+
30	Not used	2.60+
31	Not used	2.60+



32	Supervisor remote	2.60+
33	Status fans	2.60+
34	Status compressor / open valve	2.60+
35	Status pumpdown / close valve	2.60+
36	Status electrical heater 1	2.60+
37	Status humidifier boiler	2.60+
38	Status humidifier feed	2.60+
39	Status humidifier drain	2.60+
40	Status dehumidification	2.60+
41	Status electrical Heater 2	2.60+
42	Status manual humidifier drain	2.60+
43	Not used	2.60+
44	Not used	2.60+
45	Not used	2.60+
46	Not used	2.60+
47	Not used	2.60+
48	Not used	2.60+
49	Status-Report-Acknowledge	2.60+

**IMPORTANT:**

Read the document 'Hirolink for Modbus V X.XX - General Documentation' (X.XX is a placeholder for the current version of the Hirolink) for a description on how to use the coils marked with 'Command'.

**Status-Report-Acknowledge (Coil #49):**

Read the document 'Hirolink for Modbus V X.XX - General Documentation' (X.XX is a placeholder for the current version of the Hirolink) for a description on how to use this data-point.

**Cooling Configuration (Coils #14-#16):**

To set the cooling-configuration, you have to combine these 3 coils in the following way:

Cooling Configuration	Coil #14	Coil #15	Coil #16
DIRECT EXPANSION	0	0	0
CHILLED WATER	0	0	1
CHILLED WATER + SUPER-SAVER	0	1	0
DIRECT EXPANSION + ALARM-BOARD	0	1	1
CHILLED WATER + ALARM-BOARD	1	0	0
CHILLED WATER (REVERSED)	1	0	1

### 3.2 Input-Status

Input-Status #	Usage	SW-Version
1	Alarm active	2.60+
2	Warning active	2.60+
3	Alarm acknowledge active	2.60+
4	Manual drain active	2.60+
5	Standard-settings active	2.60+
6	Not used	2.60+
7	Not used	2.60+
8	Not used	2.60+
9	Remote on/off	2.60+
10	High pressure compressor	2.60+
11	Low pressure compressor	2.60+
12	Clogged filters	2.60+
13	Heaters overheated	2.60+
14	User input	2.60+
15	Humidifier level	2.60+

### 3.3 Holding Register

Register #	Usage	Range; Unit	SW-Version
1	Status-Report-Acknowledge	See description below	2.60+
2	Temperature-setpoint	150 - 500; [1/10 °C]	2.60+
3	Humidity-setpoint	200 - 800; [1/10 %RH]	2.60+
4	Integration factor	0->No integration, 5-15; [min]	2.60+
5	Temperature proportional band	5 - 50; [2/10 K]	2.60+
6	Humidity proportional band	2 - 20; [%RH]	2.60+
7	Humidity control	128->Proportional, 40->On/Off	2.60+
8	Dehumidification hysteresis	25 - 75; [%]	2.60+
9	Autorestart time	0->No autorestart, 1-60; [s]	2.60+
10	High temperature warning level	0 -> No warning; 1 - 99; [°C]	2.60+
11	Low temperature warning level	0 -> No warning; 1 - 99; [°C]	2.60+
12	High humidity warning level	0 -> No warning; 1 - 99; [%RH]	2.60+
13	Low humidity warning level	0 -> No warning; 1 - 99; [%RH]	2.60+
14	High supply temperature warning level	0 -> No warning; 1 - 99; [°C]	2.60+
15	Low supply temperature warning level	0 -> No warning; 1 - 99; [°C]	2.60+
16	High temperature alarm level	0 -> No alarm; 1 - 99; [°C]	2.60+
17	Low temperature alarm level	0 -> No alarm; 1 - 99; [°C]	2.60+
18	High humidity alarm level	0 -> No alarm; 1 - 99; [%RH]	2.60+
19	Low humidity alarm level	0 -> No alarm; 1 - 99; [%RH]	2.60+
20	High supply temperature alarm level	0 -> No alarm; 1 - 99; [°C]	2.60+
21	Low supply temperature alarm level	0 -> No alarm; 1 - 99; [°C]	2.60+
22	Low airflow warning level	0 - 100; [%]	2.60+
23	Low pressure alarm delay	0 - 5; [min]	2.60+
24	Humidifier supply voltage	1 -> 240V, 2 -> 380V, 3 -> 460V, 4 -> 575V	2.60+
25	Humidifier model	1 -> 21L, 2 -> 51L, 3 -> 51H, 4 -> 93L, 5 -> 93H, 6 -> HM2, 7. -> HT5, 8 -> HT9, 9 -> Ext	2.60+
26	Humidifier steam output	0 -> No humidification; 1 -> 30%, 2 -> 40%, 3 -> 50%, 4 -> 60%, 5 -> 70%, 6 -> 80%, 7 -> 90%, 8 -> 100 %	2.60+

27	Heating steps	2 - 3 (only if 2 electrical heaters are installed)	2.60+
28	Valve running time	50 - 500; [s]	2.60+
29	Temperature-sensor-offset	-99 - 99; [1/10 K]	2.60+
30	Humidity-sensor-offset	-300 - 300; [%RH]	2.60+
31	Conditioner working hours	0 - 50000; [h]	2.60+
32	Conditioner working hours maximum	0 - 50000; [h]	2.60+
33	Compressor working hours	0 - 50000; [h]	2.60+
34	Compressor working hours maximum	0 - 50000; [h]	2.60+
35	Humidifier working hours	0 - 50000; [h]	2.60+
36	Humidifier working hours maximum	0 - 50000; [h]	2.60+
37	Sleep mode deadband	2 - 16, 255 -> System off; [°C]	2.60+
38	Sleep mode days	Bit 0 -> Mon, Bit 1 -> Tue, Bit 2 -> Wed, Bit 3 -> Thu, Bit 4 -> Fri, Bit 5 -> Sat, Bit 6 -> Sun	2.60+
39	Sleep from time 1	Low byte -> min., high byte -> hours	2.60+
40	Sleep until time 1	Low byte -> min., high byte -> hours	2.60+
41	Sleep from time 2	Low byte -> min., high byte -> hours	2.60+
42	Sleep until time 2	Low byte -> min., high byte -> hours	2.60+
43	Language	0 -> English, 1 -> Italian, 2 -> German, 3 -> French, 4 -> Portuguese, 5 -> Spanish, 6 -> Swedish, 7 -> Greek	2.60+
44	Hirosensor #1 Value #1-Offset	-99 - 99; [1/10 K]	2.60+
45	Hirosensor #1 Value #2-Offset	-300 - 300; [%RH] or -99 - 99; [1/10 K]	2.60+
46	Hirosensor #2 Value #1-Offset	-99 - 99; [1/10 K]	2.60+
47	Hirosensor #2 Value #2-Offset	-300 - 300; [%RH] or -99 - 99; [1/10 K]	2.60+
48	EEAP-Sensor Temperature-Offset	-99 - 99; [1/10 K]	2.60+
49	EEAP-Sensor Humidity-Offset	-300 - 300; [%RH]	2.60+
50	Discharge-Air-Temperature-Sensor Offset	-99 - 99 K; [1/10 K]	2.60+
51	Hirosensor #1 installed (Read only)	0 -> No; 1 -> Humitemp; 2 -> Hirotemp	2.60+
52	Hirosensor #2 installed (Read only)	0 -> No; 1 -> Humitemp; 2 -> Hirotemp	2.60+
53	EEAP-Sensor #1 installed (Read only)	0 -> No; 1 -> Yes	2.60+
54	Heater working hours	0 - 50000; [h]	2.60+
55	Not used		2.60+
56	Supply air setpoint	45 -> NO; 50 - 250; [1/10 °C]	2.60+
57	El. heater 1 configuration	0 -> No; 1 -> Yes; 2 -> High temp. warning output	2.60+
58	El. heater 2 configuration	0 -> No; 1 -> Yes; 2 -> High temp. alarm output	2.60+

### Status-Report-Acknowledge (Holding Register #1):

Read the document 'Hirolink for Modbus V X.XX - General Documentation' (X.XX is a placeholder for the current version of the Hirolink) for a description on how to use this data-point.

### 3.4 Input-Register

Register #	Usage	Unit	SW-Version
1	Event-ID	ID identifying the event	2.60+
2	Not used		2.60+
3	Minute	Minute, when event occurred	2.60+
4	Hour	Hour, when event occurred	2.60+
5	Date	Date, when event occurred	2.60+
6	Event-Type	0 -> message, 1 -> warning, 2 -> alarm, 3 -> reset	2.60+
7	System status	See explanation below	2.60+
8	Actual temperature	[1/10 °C]	2.60+
9	Actual humidity	[1/10 %RH]	2.60+
10	Actual temperature EEAP	[1/10 °C]	2.60+
11	Actual humidity EEAP	[1/10 %RH]	2.60+
12	Liquistat sensor	[1/100 V]	2.60+
13	Airflow rate sensor	[1/100 V]	2.60+
14	Humidifier current	[1/100 A]	2.60+
15	Chilled water ramp	[%]	2.60+
16	Super saver ramp	[%]	2.60+
17	Hot water ramp	[%]	2.60+
18	Humidifier ramp	[%]	2.60+
19	Hirosensor #1 Value #1	[1/10 °C]	2.60+
20	Hirosensor #1 Value #2	[1/10 %RH] or [1/10 °C]	2.60+
21	Hirosensor #2 Value #1	[1/10 °C]	2.60+
22	Hirosensor #2 Value #2	[1/10 %RH] or [1/10 °C]	2.60+
23	Discharge Air Temperature	[1/10 °C]	2.60+
24	Sensor-Configuration	See explanation below	2.60+

#### Status-Report-Block (Input Register #1 - #6):

Read the document 'Hirolink for Modbus V X.XX - General Documentation' (X.XX is a placeholder for the current version of the Hirolink) for a description on how to use these data-points.

#### System Status (Input Register #7):

The values of this item correspond to the following system-states:

- 0..System off
- 1..System on
- 2..Manual on
- 3..Remote off
- 4..Remote on
- 5..Sleep mode on

#### Sensor Configuration (Input Register #24):

The values of this item correspond to the following configurations:

- 0..PTC only
- 1..Humitemp only
- 2..Humitemp + PTC
- 3..Humitemp + Hirosensor
- 4..Humitemp + Hirosensor + PTC

### 3.5 Events

#### **IMPORTANT:**

Read the document 'Hirolink for Modbus V X.XX - General Documentation' (X.XX is a placeholder for the current version of the Hirolink) for a detailed description on how to use these data-points.

In the following list you can see all Events and Event-IDs available for Compact-Graphic-units:

Event-ID	Event-Description	Event-Type	SW-Version
1	HIGH PRESSURE COMPRESSOR, check freon circuit + condenser	Alarm	2.60+
2	LOW PRESSURE COMPRESSOR, check freon circuit	Alarm	2.60+
3	EL. PROTECTION COMPRESSOR, check freon circuit + condenser	Alarm	2.60+
4	NOT USED		2.60+
5	NOT USED		2.60+
6	NOT USED		2.60+
7	NOT USED		2.60+
8	NOT USED		2.60+
9	NOT USED		2.60+
10	CHILLED WATER TEMP. TOO HIGH FOR SAFE OPERATION	Warning	2.60+
11	CHILLED WATER FLOW TOO LOW FOR SAFE OPERATION	Warning	2.60+
12	EL. HEATERS OVERHEATING, check fans and sensors	Warning	2.60+
13	LOSS OF AIR FLOW, check fans	Warning	2.60+
14	CLOGGED FILTERS, check air filters	Warning	2.60+
15	NOT USED		2.60+
16	WATER LEAKAGE DETECTION, check hydraulic circuit	Warning	2.60+
17	USER INPUT TRIGGERED	Warning	2.60+
18	NOT USED		2.60+
19	NOT USED		2.60+
20	HUMIDIFIER FAILURE	Alarm	2.60+
21	HUMIDIFIER SHORT CIRCUIT, check el. circuit + cylinder	Alarm	2.60+
22	HUMIDIFIER HIGH CURRENT, check cylinder	Alarm	2.60+
23	HUMIDIFIER MAINS FAILURE, check electrical circuit	Alarm	2.60+
24	HUMIDIFIER WITHOUT WATER, check water supply	Warning	2.60+
25	HUMIDIFIER CYLINDER WORN, please replace	Warning	2.60+
26	LOSS OF AIR FLOW, check fans	Alarm	2.60+
27	USER INPUT TRIGGERED	Alarm	2.60+
28	NOT USED		2.60+
29	NOT USED		2.60+
30	HIGH ROOM TEMPERATURE	Warning	2.60+
31	LOW ROOM TEMPERATURE	Warning	2.60+
32	HIGH ROOM HUMIDITY	Warning	2.60+
33	LOW ROOM HUMIDITY	Warning	2.60+
34	HIGH ROOM TEMPERATURE	Alarm	2.60+
35	LOW ROOM TEMPERATURE	Alarm	2.60+
36	HIGH ROOM HUMIDITY	Alarm	2.60+
37	LOW ROOM HUMIDITY	Alarm	2.60+
38	NOT USED		2.60+
39	NOT USED		2.60+

40	CONDITIONER WORKING HOURS THRESHOLD EXCEEDED	Warning	2.60+
41	COMPRESSOR WORKING HOURS THRESHOLD EXCEEDED	Warning	2.60+
42	NOT USED		2.60+
43	HUMIDIFIER WORKING HOURS THRESHOLD EXCEEDED	Warning	2.60+
44	HUMIDIFICATION EXTERNALLY DISABLED	Message	2.60+
45	HUMIDIFICATION EXTERNALLY ENABLED	Message	2.60+
46	HIROSENSOR #1 FAILURE, please replace sensor	Warning	2.60+
47	HIROSENSOR #2 FAILURE, please replace sensor	Warning	2.60+
48	PTC-SENSOR FAILURE, please replace sensor	Alarm	2.60+
49	MANUAL MODE	Message	2.60+
50	POWER RESTORED	Reset	2.60+
51	POWER OFF	Message	2.60+
52	SYSTEM ON	Message	2.60+
53	SYSTEM OFF	Message	2.60+
54	REMOTE ON	Message	2.60+
55	REMOTE OFF	Message	2.60+
56	ALARM RESET	Reset	2.60+
57	ALARM ACKNOWLEDGED	Message	2.60+
58	SLEEP MODE ON	Message	2.60+
59	SLEEP MODE OFF	Message	2.60+
60	RAM ERROR, replace display board	Alarm	2.60+
61	EPROM ERROR, please replace eprom	Alarm	2.60+
62	EEPROM ERROR, replace display board	Alarm	2.60+
63	DISPLAY BOARD FAILURE, please replace	Alarm	2.60+
64	NOT USED		2.60+
65	ROOM SENSOR FAILURE, please replace sensor	Alarm	2.60+
66	EEAP SENSOR FAILURE, please replace sensor	Alarm	2.60+
67	WATER PRESENCE SENSOR FAILURE, check wiring	Warning	2.60+
68	FILTER PRESSURE DROP SENSOR FAILURE	Warning	2.60+
69	PRINTING IMPOSSIBLE, check connections	Warning	2.60+
70	DISPLAY BOARD FAILURE X please replace	Alarm	2.60+
71	LOCAL ON/OFF DISABLED	Warning	2.60+
72	SLEEP MODE EXTERNALLY DISABLED	Message	2.60+
73	SLEEP MODE EXTERNALLY ENABLED	Message	2.60+
74	UNIT UNDER HIROVISOR CONTROL	Warning	2.60+
75	SENSOR CONFIGURATION RESTORED	Message	2.60+
76	HIGH SUPPLY TEMPERATURE	Warning	2.60+
77	HIGH SUPPLY TEMPERATURE	Alarm	2.60+
78	LOW SUPPLY TEMPERATURE	Warning	2.60+
79	LOW SUPPLY TEMPERATURE	Alarm	2.60+
80	WRONG SENSOR CONFIGURATION	Warning	2.60+

100	UNIT CONNECTED	Message	2.60+
101	UNIT NOT CONNECTED	Message	2.60+

## 4. Document-Changes

This appendix contains all changes that have been applied to this document up to the current version:

### 1. Changes from V 1.00 to V 1.01

All descriptions regarding the 'Status-Report' have been moved to the document 'Hirolink for Modbus V X.XX - General Documentation' (X.XX is a placeholder for the current version of the Hirolink).

## Connectivity

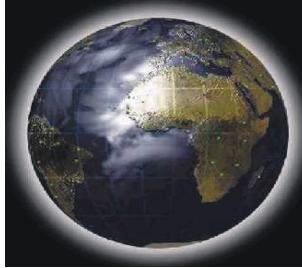

*the evolution*

## Hirolink for Modbus

(03) Items for CCAC (GWX\_FC) (Compact Graphic).doc

English

04/11/03 Release 1.01E

<b>1.</b>	<b>INTRODUCTION FOR CCAC (GWX_FC) (COMPACT GRAPHIC)</b> .....	<b>3</b>
<b>2.</b>	<b>COMPATIBILITY-LIST</b> .....	<b>3</b>
<b>3.</b>	<b>ITEMS FOR CCAC (GWX_FC) (COMPACT GRAPHIC)</b> .....	<b>4</b>
3.1	COILS .....	4
3.2	INPUT-STATUS .....	6
3.3	HOLDING REGISTER .....	6
3.4	INPUT-REGISTER .....	8
3.5	EVENTS .....	9
<b>4.</b>	<b>DOCUMENT-CHANGES</b> .....	<b>10</b>



# 1. Introduction CCAC (GWX\_FC) (Compact Graphic)

This document contains a description of all data-points that are available via the 'Hirolink for Modbus' from this type of air-conditioner.

## **IMPORTANT:**

It is vital to the correct integration of the Hirolink into a Modbus-network, that you have read and understood the topics described in the document 'Hirolink for Modbus V X.XX - General Documentation' (X.XX is a placeholder for the current version of the Hirolink). So, if you haven't read this document until now, read it first.

## 2. Compatibility-List

Before connecting a Hiromatic to the Modbus-Hirolink you must check, if the Hiromatic-software-version is compatible with this version of the Hirolink.

You can do this by checking the labels on the eprom, which is inserted into the Hiromatic. This eprom must be called GWX + Version-Number (e.g. GWX262).

To make sure that the label on the eproms is correct, you should also check the version-information, that the Hiromatic displays shortly after start-up. This information should look similar to the following illustration:

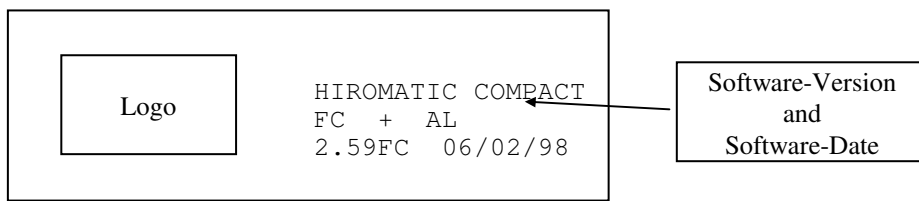

The important information in this window is only the software-version and the software-date. Make sure that the software-version installed in your installation matches one of the compatible versions listed below:

<b>Version</b>	<b>Date</b>
2.58FC	24/07/96
2.59FC	12/03/98

### 3. Items for CCAC (GWX\_FC) (Compact Graphic)

According to the Modbus-protocol-specifications the values and parameters provided by the Hiromatic are represented in 4 groups:

- Coils: Used for changeable, digital values
- Inputs: Used for not changeable, digital values
- Holding Registers: Used for changeable, analog values
- Input Registers: Used for not changeable, analog values

This Hirolink can be compatible with more than one version of this Hiromatic-type and it is possible that there have been extensions in the number of available items from one version to the next.

Therefore the column 'SW-Version' contained in the following lists provides information about the availability of each item depending on the Hiromatic-software-version. For example a entry like '2.58+' means, that this item is available from Hiromatics with software-version 2.60 and higher.

#### **IMPORTANT:**

The available data-points shown in the following chapters are numbered starting from 1, according to the Modbus-Protocol-Specification. Still some BMS start numbering the data-points from 0. So, in case that the BMS you are using starts numbering from 0, you have to decrease the listed numbers by 1.

#### **3.1 Coils**

Coil #	Usage	SW-Version
1	Set system off (Command)	2.58+
2	Set system on (Command)	2.58+
3	Set manual on (Command)	2.58+
4	Set manual drain (Command)	2.58+
5	Set alarm acknowledge (Command)	2.58+
6	Set alarm reset (Command)	2.58+
7	Set standard-settings (Command)	2.58+
8	Not used	2.58+
9	EEAP-Sensor installed	2.58+
10	User input 1 (coils 10 and 11 are used together)	2.58+
11	00..Warning; 01..Alarm; 10..Sleep mode disable	2.58+
12	Not used	2.58+
13	Not used	2.58+
14	Cooling configuration: See description below	2.58+
15	Cooling configuration: See description below	2.58+
16	Cooling configuration: See description below	2.58+
17	Not used	2.58+
18	Water leakage detector installed	2.58+
19	Not used	2.58+
20	Remote off installed	2.58+
21	Local on/off disabled	2.58+
22	Fan failure: 0..Warning,1..Alarm	2.58+
23	Temperature: 0.. °C,1..F	2.58+
24	Sleepmode restore	2.58+
25	Dehumidification inverse	2.58+
26	Dehumidification enabled	2.58+
27	Pumpdown installed	2.58+
28	Not used	2.58+
29	Not used	2.58+
30	Not used	2.58+
31	Not used	2.58+

32	Supervisor remote	2.58+
33	Status fans	2.58+
34	Status compressor / open valve	2.58+
35	Status pumpdown / close valve	2.58+
36	Status electrical heater 1	2.58+
37	Status humidifier boiler	2.58+
38	Status humidifier feed	2.58+
39	Status humidifier drain	2.58+
40	Status dehumidification	2.58+
41	Status electrical Heater 2	2.58+
42	Status manual humidifier drain	2.58+
43	Not used	2.58+
44	Not used	2.58+
45	Not used	2.58+
46	Not used	2.58+
47	Not used	2.58+
48	Not used	2.58+
49	Status-Report-Acknowledge	2.58+

**IMPORTANT:**

Read the document 'Hirolink for Modbus V X.XX - General Documentation' (X.XX is a placeholder for the current version of the Hirolink) for a description on how to use the coils marked with 'Command'.

**Status-Report-Acknowledge (Coil #49):**

Read the document 'Hirolink for Modbus V X.XX - General Documentation' (X.XX is a placeholder for the current version of the Hirolink) for a description on how to use this data-point.

**Cooling Configuration (Coils #14-#16):**

To set the cooling-configuration, you have to combine these 3 coils in the following way:

Cooling Configuration	Coil #14	Coil #15	Coil #16
DIRECT EXPANSION	0	0	0
CHILLED WATER	0	0	1
CHILLED WATER + SUPER-SAVER	0	1	0
DIRECT EXPANSION + ALARM-BOARD	0	1	1
CHILLED WATER + ALARM-BOARD	1	0	0
CHILLED WATER (REVERSED)	1	0	1

### 3.2 Input-Status

Input-Status #	Usage	SW-Version
1	Alarm active	2.58+
2	Warning active	2.58+
3	Alarm acknowledge active	2.58+
4	Manual drain active	2.58+
5	Standard-settings active	2.58+
6	Not used	2.58+
7	Not used	2.58+
8	Not used	2.58+
9	Remote on/off	2.58+
10	High pressure compressor	2.58+
11	Low pressure compressor	2.58+
12	Clogged filters	2.58+
13	Heaters overheated	2.58+
14	User input	2.58+
15	Humidifier level	2.58+

### 3.3 Holding Register

Register #	Usage	Range; Unit	SW-Version
1	Status-Report-Acknowledge	See description below	2.58+
2	Temperature-setpoint	150 - 500; [1/10 °C]	2.58+
3	Humidity-setpoint	200 - 800; [1/10 %RH]	2.58+
4	Integration factor	0->No integration, 5-15; [min]	2.58+
5	Temperature proportional band	5 - 50; [2/10 K]	2.58+
6	Humidity proportional band	2 - 20; [%RH]	2.58+
7	Humidity control	128->Proportional, 40->On/Off	2.58+
8	Dehumidification hysteresis	25 - 75; [%]	2.58+
9	Autorestart time	0->No autorestart, 1-60; [s]	2.58+
10	High temperature warning level	0 -> No warning; 1 - 99; [°C]	2.58+
11	Low temperature warning level	0 -> No warning; 1 - 99; [°C]	2.58+
12	High humidity warning level	0 -> No warning; 1 - 99; [%RH]	2.58+
13	Low humidity warning level	0 -> No warning; 1 - 99; [%RH]	2.58+
14	High temperature alarm level	0 -> No alarm; 1 - 99; [°C]	2.58+
15	Low temperature alarm level	0 -> No alarm; 1 - 99; [°C]	2.58+
16	High humidity alarm level	0 -> No alarm; 1 - 99; [%RH]	2.58+
17	Low humidity alarm level	0 -> No alarm; 1 - 99; [%RH]	2.58+
18	High supply temperature alarm level	0 -> No alarm; 1 - 99; [°C]	2.58+
19	Low supply temperature alarm level	0 -> No alarm; 1 - 99; [°C]	2.58+
20	Humidifier supply voltage	1 -> 240V, 2 -> 380V, 3 -> 460V, 4 -> 575V	2.58+
21	Humidifier model	1 -> 21L, 2 -> 51L, 3 -> 51H, 4 -> 93L, 5 -> 93H, 6 -> HM2, 7. -> HT5, 8 -> HT9, 9 -> Ext	2.58+
22	Humidifier steam output	0 -> No humidification; 1 -> 30%, 2 -> 40%, 3 -> 50%, 4 -> 60%, 5 -> 70%, 6 -> 80%, 7 -> 90%, 8 -> 100 %	2.58+
23	Heating steps	2 - 3 (only if 2 electrical heaters are installed)	2.58+
24	Valve running time	50 - 500; [s]	2.58+
25	Temperature-sensor-offset	-99 - 99; [1/10 K]	2.58+

26	Humidity-sensor-offset	-300 - 300; [%RH]	2.58+
27	Conditioner working hours	0 - 50000; [h]	2.58+
28	Conditioner working hours maximum	0 - 50000; [h]	2.58+
29	Compressor working hours	0 - 50000; [h]	2.58+
30	Compressor working hours maximum	0 - 50000; [h]	2.58+
31	Humidifier working hours	0 - 50000; [h]	2.58+
32	Humidifier working hours maximum	0 - 50000; [h]	2.58+
33	Sleep mode deadband	2 - 16, 255 -> System off; [°C]	2.58+
34	Sleep mode days	Bit 0 -> Mon, Bit 1 -> Tue, Bit 2 -> Wed, Bit 3 -> Thu, Bit 4 -> Fri, Bit 5 -> Sat, Bit 6 -> Sun	2.58+
35	Sleep from time 1	Low byte -> min., high byte -> hours	2.58+
36	Sleep until time 1	Low byte -> min., high byte -> hours	2.58+
37	Sleep from time 2	Low byte -> min., high byte -> hours	2.58+
38	Sleep until time 2	Low byte -> min., high byte -> hours	2.58+
39	Language	0 -> English, 1 -> Italian, 2 -> German, 3 -> French, 4 -> Portuguese, 5 -> Spanish, 6 -> Swedish, 7 -> Greek	2.58+
40	Hirosensor #1 Value #1-Offset	-99 - 99; [1/10 K]	2.58+
41	Hirosensor #1 Value #2-Offset	-300 - 300; [%RH] or -99 - 99; [1/10 K]	2.58+
42	Hirosensor #2 Value #1-Offset	-99 - 99; [1/10 K]	2.58+
43	Hirosensor #2 Value #2-Offset	-300 - 300; [%RH] or -99 - 99; [1/10 K]	2.58+
44	EEAP-Sensor Temperature-Offset	-99 - 99; [1/10 K]	2.58+
45	EEAP-Sensor Humidity-Offset	-300 - 300; [%RH]	2.58+
46	Discharge-Air-Temperature-Sensor Offset	-99 - 99 K; [1/10 K]	2.58+
47	Hirosensor #1 installed (Read only)	0 -> No; 1 -> Humitemp; 2 -> Hirotemp	2.58+
48	Hirosensor #2 installed (Read only)	0 -> No; 1 -> Humitemp; 2 -> Hirotemp	2.58+
49	EEAP-Sensor #1 installed (Read only)	0 -> No; 1 -> Yes	2.58+
50	Heater working hours	0 - 50000; [h]	2.58+
51	Not used		2.58+
52	Supply air setpoint	45 -> NO; 50 - 250; [1/10 °C]	2.58+
53	El. heater 1 configuration	0 -> No; 1 -> Yes; 2 -> High temp. warning output	2.58+
54	El. heater 2 configuration	0 -> No; 1 -> Yes; 2 -> High temp. alarm output	2.58+

### Status-Report-Acknowledge (Holding Register #1):

Read the document 'Hirolink for Modbus V X.XX - General Documentation' (X.XX is a placeholder for the current version of the Hirolink) for a description on how to use this data-point.

### 3.4 Input-Register

Register #	Usage	Unit	SW-Version
1	Event-ID	ID identifying the event	2.58+
2	Not used		2.58+
3	Minute	Minute, when event occurred	2.58+
4	Hour	Hour, when event occurred	2.58+
5	Date	Date, when event occurred	2.58+
6	Event-Type	0 -> message, 1 -> warning, 2 -> alarm, 3 -> reset	2.58+
7	System status	See explanation below	2.58+
8	Actual temperature	[1/10 °C]	2.58+
9	Actual humidity	[1/10 %RH]	2.58+
10	Actual temperature EEAP	[1/10 °C]	2.58+
11	Actual humidity EEAP	[1/10 %RH]	2.58+
12	Liquistat sensor	[1/100 V]	2.58+
13	Airflow rate sensor	[1/100 V]	2.58+
14	Humidifier current	[1/100 A]	2.58+
15	Chilled water ramp	[%]	2.58+
16	Super saver ramp	[%]	2.58+
17	Hot water ramp	[%]	2.58+
18	Humidifier ramp	[%]	2.58+
19	Hirosensor #1 Value #1	[1/10 °C]	2.58+
20	Hirosensor #1 Value #2	[1/10 %RH] or [1/10 °C]	2.58+
21	Hirosensor #2 Value #1	[1/10 °C]	2.58+
22	Hirosensor #2 Value #2	[1/10 %RH] or [1/10 °C]	2.58+
23	Discharge Air Temperature	[1/10 °C]	2.58+
24	Sensor-Configuration	See explanation below	2.58+

#### Status-Report-Block (Input Register #1 - #6):

Read the document 'Hirolink for Modbus V X.XX - General Documentation' (X.XX is a placeholder for the current version of the Hirolink) for a description on how to use these data-points.

#### System Status (Input Register #7):

The values of this item correspond to the following system-states:

- 0..System off
- 1..System on
- 2..Manual on
- 3..Remote off
- 4..Remote on
- 5..Sleep mode on

#### Sensor Configuration (Input Register #24):

The values of this item correspond to the following configurations:

- 0..PTC only
- 1..Humitemp only
- 2..Humitemp + PTC
- 3..Humitemp + Hirosensor
- 4..Humitemp + Hirosensor + PTC

### 3.5 Events

#### **IMPORTANT:**

Read the document 'Hirolink for Modbus V X.XX - General Documentation' (X.XX is a placeholder for the current version of the Hirolink) for a detailed description on how to use these data-points.

In the following list you can see all Events and Event-IDs available for Compact-Graphic-Free cooling units:

Event-ID	Event-Description	Event-Type	SW-Version
1	HIGH PRESSURE COMPRESSOR, check freon circuit + condenser	Alarm	2.58+
2	LOW PRESSURE COMPRESSOR, check freon circuit	Alarm	2.58+
3	EL. PROTECTION COMPRESSOR, check freon circuit + condenser	Alarm	2.58+
4	NOT USED		2.58+
5	NOT USED		2.58+
6	NOT USED		2.58+
7	NOT USED		2.58+
8	NOT USED		2.58+
9	NOT USED		2.58+
10	CHILLED WATER TEMP. TOO HIGH FOR SAFE OPERATION	Warning	2.58+
11	CHILLED WATER FLOW TOO LOW FOR SAFE OPERATION	Warning	2.58+
12	EL. HEATERS OVERHEATING, check fans and sensors	Warning	2.58+
13	LOSS OF AIR FLOW, check fans	Warning	2.58+
14	CLOGGED FILTERS, check air filters	Warning	2.58+
15	NOT USED		2.58+
16	WATER LEAKAGE DETECTION, check hydraulic circuit	Warning	2.58+
17	USER INPUT TRIGGERED	Warning	2.58+
18	NOT USED		2.58+
19	NOT USED		2.58+
20	HUMIDIFIER FAILURE	Alarm	2.58+
21	HUMIDIFIER SHORT CIRCUIT, check el. circuit + cylinder	Alarm	2.58+
22	HUMIDIFIER HIGH CURRENT, check cylinder	Alarm	2.58+
23	HUMIDIFIER MAINS FAILURE, check electrical circuit	Alarm	2.58+
24	HUMIDIFIER WITHOUT WATER, check water supply	Warning	2.58+
25	HUMIDIFIER CYLINDER WORN, please replace	Warning	2.58+
26	LOSS OF AIR FLOW, check fans	Alarm	2.58+
27	USER INPUT TRIGGERED	Alarm	2.58+
28	NOT USED		2.58+
29	NOT USED		2.58+
30	HIGH ROOM TEMPERATURE	Warning	2.58+
31	LOW ROOM TEMPERATURE	Warning	2.58+
32	HIGH ROOM HUMIDITY	Warning	2.58+
33	LOW ROOM HUMIDITY	Warning	2.58+
34	HIGH ROOM TEMPERATURE	Alarm	2.58+
35	LOW ROOM TEMPERATURE	Alarm	2.58+
36	HIGH ROOM HUMIDITY	Alarm	2.58+
37	LOW ROOM HUMIDITY	Alarm	2.58+
38	NOT USED		2.58+
39	NOT USED		2.58+

40	CONDITIONER WORKING HOURS THRESHOLD EXCEEDED	Warning	2.58+
41	COMPRESSOR WORKING HOURS THRESHOLD EXCEEDED	Warning	2.58+
42	NOT USED		2.58+
43	HUMIDIFIER WORKING HOURS THRESHOLD EXCEEDED	Warning	2.58+
44	HUMIDIFICATION EXTERNALLY DISABLED	Message	2.58+
45	HUMIDIFICATION EXTERNALLY ENABLED	Message	2.58+
46	HIROSENSOR #1 FAILURE, please replace sensor	Warning	2.58+
47	HIROSENSOR #2 FAILURE, please replace sensor	Warning	2.58+
48	PTC-SENSOR FAILURE, please replace sensor	Alarm	2.58+
49	MANUAL MODE	Message	2.58+
50	POWER RESTORED	Reset	2.58+
51	POWER OFF	Message	2.58+
52	SYSTEM ON	Message	2.58+
53	SYSTEM OFF	Message	2.58+
54	REMOTE ON	Message	2.58+
55	REMOTE OFF	Message	2.58+
56	ALARM RESET	Reset	2.58+
57	ALARM ACKNOWLEDGED	Message	2.58+
58	SLEEP MODE ON	Message	2.58+
59	SLEEP MODE OFF	Message	2.58+
60	RAM ERROR, replace display board	Alarm	2.58+
61	EPROM ERROR, please replace eprom	Alarm	2.58+
62	EEPROM ERROR, replace display board	Alarm	2.58+
63	DISPLAY BOARD FAILURE, please replace	Alarm	2.58+
64	NOT USED		2.58+
65	ROOM SENSOR FAILURE, please replace sensor	Alarm	2.58+
66	EEAP SENSOR FAILURE, please replace sensor	Alarm	2.58+
67	WATER PRESENCE SENSOR FAILURE, check wiring	Warning	2.58+
68	FILTER PRESSURE DROP SENSOR FAILURE	Warning	2.58+
69	PRINTING IMPOSSIBLE, check connections	Warning	2.58+
70	DISPLAY BOARD FAILURE X please replace	Alarm	2.58+
71	LOCAL ON/OFF DISABLED	Warning	2.58+
72	SLEEP MODE EXTERNALLY DISABLED	Message	2.58+
73	SLEEP MODE EXTERNALLY ENABLED	Message	2.58+
74	UNIT UNDER HIROVISOR CONTROL	Warning	2.58+
75	SENSOR CONFIGURATION RESTORED	Message	2.58+
76	WRONG SENSOR CONFIGURATION	Warning	2.58+

100	UNIT CONNECTED	Message	2.58+
101	UNIT NOT CONNECTED	Message	2.58+

## 4. Document-Changes

This appendix contains all changes that have been applied to this document up to the current version:

### 1. Changes from V 1.00 to V 1.01

All descriptions regarding the 'Status-Report' have been moved to the document 'Hirolink for Modbus V X.XX - General Documentation' (X.XX is a placeholder for the current version of the Hirolink).



# Connectivity



*the evolution*

## Hirolink for Modbus

**(04) Items for CCAC (GTF) (Advanced Graphic).doc**

**English**

04/11/03 Release 1.01E

1. INTRODUCTION CCAC (GTF) (ADVANCED GRAPHIC)..... 3

2. COMPATIBILITY-LIST ..... 3

3. ITEMS FOR CCAC (GTF) (ADVANCED GRAPHIC)..... 4

3.1 COILS..... 4

3.2 INPUT-STATUS ..... 6

3.3 HOLDING REGISTER ..... 7

3.4 INPUT-REGISTER ..... 9

3.5 EVENTS..... 10

4. DOCUMENT-CHANGES ..... 12

# 1. Introduction CCAC (GTF) (Advanced Graphic)

This document contains a description of all data-points that are available via the 'Hirolink for Modbus' from this type of air-conditioner.

## **IMPORTANT:**

It is vital to the correct integration of the Hirolink into a Modbus-network, that you have read and understood the topics described in the document 'Hirolink for Modbus V X.XX - General Documentation' (X.XX is a placeholder for the current version of the Hirolink). So, if you haven't read this document until now, read it first.

## 2. Compatibility-List

Before connecting a Hiromatic to the Modbus-Hirolink you must check, if the Hiromatic-software-version is compatible with this version of the Hirolink.

You can do this by checking the labels on the eproms, which are inserted into the Hiromatic and the Macroface. The eprom inserted in the Hiromatic must be called GTF + Version-Number (e.g. GTF262) and the one inserted in the Microface must be called MTF + Version-Number (e.g. MTF262).

To make sure that the label on the eproms is correct, you should also check the version-information, that the Hiromatic displays shortly after start-up. This information should look similar to the following illustration:

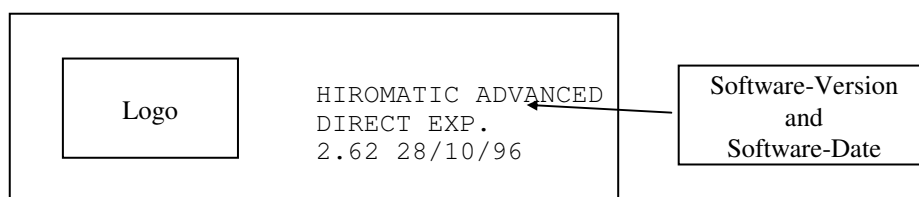

The important information in this window is only the software-version and the software-date. Make sure that the software-version installed in your installation matches one of the compatible versions listed below:

<b>Version</b>	<b>Date</b>
2.60	01.04.1996
2.61	25.06.1996
2.62	28.10.1996

### 3. Items for CCAC (GTF) (Advanced Graphic)

According to the Modbus-protocol-specifications the values and parameters provided by the Hiromatic are represented in 4 groups:

- Coils: Used for changeable, digital values
- Inputs: Used for not changeable, digital values
- Holding Registers: Used for changeable, analog values
- Input Registers: Used for not changeable, analog values

This Hiolink can be compatible with more than one version of this Hiromatic-type and it is possible that there have been extensions in the number of available items from one version to the next.

Therefore the column 'SW-Version' contained in the following lists provides information about the availability of each item depending on the Hiromatic-software-version. For example a entry like '2.60+' means, that this item is available from Hiromatics with software-version 2.60 and higher.

**IMPORTANT:**

The available data-points shown in the following chapters are numbered starting from 1, according to the Modbus-Protocol-Specification. Still some BMS start numbering the data-points from 0. So, in case that the BMS you are using starts numbering from 0, you have to decrease the listed numbers by 1.

#### 3.1 Coils

Coil #	Usage	SW-Version
1	Set system off (Command)	2.60+
2	Set system on (Command)	2.60+
3	Set manual on (Command)	2.60+
4	Set manual drain (Command)	2.60+
5	Set alarm acknowledge (Command)	2.60+
6	Set alarm reset (Command)	2.60+
7	Set standard-settings (Command)	2.60+
8	Not used	2.60+
9	Not used	2.60+
10	User input 1: 0..Warning,1..Alarm	2.60+
11	User input 1: sleep mode disable	2.60+
12	User input 1: 0..Warning,1..Alarm	2.60+
13	User input 1: sleep mode disable	2.60+
14	Not used	2.60+
15	Not used	2.60+
16	Not used	2.60+
17	Setpoint shifting installed	2.60+
18	Water leakage detector installed	2.60+
19	Not used	2.60+
20	Remote off installed	2.60+
21	Local on/off disabled	2.60+
22	Fan failure: 0..Warning,1..Alarm	2.60+
23	Temperature: 0.. °C,1..F	2.60+
24	Sleepmode restore	2.60+
25	Not used	2.60+
26	Not used	2.60+
27	Not used	2.60+
28	Not used	2.60+

29	Not used	2.60+
30	Not used	2.60+
31	Not used	2.60+
32	Supervisor remote	2.60+
33	Manual fans	2.60+
34	Manual dehumidification	2.60+
35	Manual compressor 1	2.60+
36	Not used	2.60+
37	Not used	2.60+
38	Manual compressor 2	2.60+
39	Not used	2.60+
40	Not used	2.60+
41	Not used	2.60+
42	Manual hot gas / hot water	2.60+
43	Manual electrical heater 1	2.60+
44	Manual electrical heater 2	2.60+
45	Manual humidifier boiler	2.60+
46	Not used	2.60+
47	Not used	2.60+
48	Not used	2.60+
49	Dehumidification inverse	2.60+
50	Dehumidification installed	2.60+
51	Not used	2.60+
52	Not used	2.60+
53	Not used	2.60+
54	Not used	2.60+
55	Not used	2.60+
56	Not used	2.60+
57	Not used	2.60+
58	Hot gas installed	2.60+
59	Electrical heater 1 installed	2.60+
60	Electrical heater 2 installed	2.60+
61	Not used	2.60+
62	Not used	2.60+
63	Not used	2.60+
64	Not used	2.60+
65	Status-Report-Acknowledge	2.60+

**IMPORTANT:**

Read the document 'Hirolink for Modbus V X.XX - General Documentation' (X.XX is a placeholder for the current version of the Hirolink) for a description on how to use the coils marked with 'Command'.

**Status-Report-Acknowledge (Coil #65):**

Read the document 'Hirolink for Modbus V X.XX - General Documentation' (X.XX is a placeholder for the current version of the Hirolink) for a description on how to use this data-point.

### 3.2 Input-Status

Input-Status #	Usage	SW-Version
1	Alarm active	2.60+
2	Warning active	2.60+
3	Alarm acknowledge active	2.60+
4	Manual drain active	2.60+
5	Standard-settings active	2.60+
6	Not used	2.60+
7	Not used	2.60+
8	Not used	2.60+
9	Remote on/off	2.60+
10	Low pressure compressor 1	2.60+
11	High pressure compressor 1	2.60+
12	Thermal protection compressor 1	2.60+
13	Low pressure compressor 2	2.60+
14	High pressure compressor 2	2.60+
15	Thermal protection compressor 2	2.60+
16	Chilled water OK	2.60+
17	Hot water OK	2.60+
18	Elec. heaters overheated	2.60+
19	Fire or smoke	2.60+
20	Clogged filters	2.60+
21	Fan failure	2.60+
22	User input 1	2.60+
23	User input 2	2.60+
24	Humidifier level	2.60+
25	Status fans	2.60+
26	Status dehumidification	2.60+
27	Status compressor 1	2.60+
28	Status second speed 1	2.60+
29	Status pump down 1	2.60+
30	Status compressor 2	2.60+
31	Status second speed 2	2.60+
32	Status pump down 2	2.60+
33	Status freecooling	2.60+
34	Status hot gas / hot water	2.60+
35	Status electrical heater 1	2.60+
36	Status electrical heater 2	2.60+
37	Status humidifier boiler	2.60+
38	Status humidifier feed	2.60+
39	Status humidifier drain	2.60+
40	Not used	2.60+

### 3.3 Holding Register

Register #	Usage	Range; Unit	SW-Version
1	Status-Report-Acknowledge	See description below	2.60+
2	Cold water ramp 1 (manual)	0 - 100; [%]	2.60+
3	Cold water ramp 2 (manual)	0 - 100; [%]	2.60+
4	Hot water ramp (manual)	0 - 100; [%]	2.60+
5	Fan water ramp (manual)	0 - 100; [%]	2.60+
6	Compressor 1 ramp (manual)	0 - 100; [%]	2.60+
7	Compressor 2 ramp (manual)	0 - 100; [%]	2.60+
8	Humidifier ramp (manual)	0 - 100; [%]	2.60+
9	Temperature-setpoint	175 - 300; [1/10 °C]	2.60+
10	Humidity-setpoint	350 - 750; [1/10 %RH]	2.60+
11	Temperature proportional band	5 - 50; [2/10 K]	2.60+
12	Humidity proportional band	5 - 20; [%RH]	2.60+
13	Humidity control	128->Proportional, 40->On/Off	2.60+
14	Dehumidification hysteresis	25 - 75; [%]	2.60+
15	High temperature warning level	10 - 50; [°C]	2.60+
16	Low temperature warning level	0 - 30; [°C]	2.60+
17	High humidity warning level	30 - 99; [%RH]	2.60+
18	Low humidity warning level	10 - 70; [%RH]	2.60+
19	High temperature alarm level	10 - 50; [°C]	2.60+
20	Low temperature alarm level	0 - 30; [°C]	2.60+
21	High humidity alarm level	30 - 99; [%RH]	2.60+
22	Low humidity alarm level	10 - 70; [%RH]	2.60+
23	Supply air temperature	45 -> No, 50 - 250; [1/10 °C]	2.60+
24	Freecooling at	4 - 15; [°C]	2.60+
25	Freecooling delay	0 - 15; [min]	2.60+
26	Integration factor	0 -> No integration, 5-15; [min]	2.60+
27	Low pressure alarm delay	0 - 5; [min]	2.60+
28	Clogged filter warning level	50 - 250; [Pa]	2.60+
29	Software version	0 -> DE, 1-> DF, 2 -> FC, 3 -> CW, 4 -> CW+SS, 5 -> DE+AL, 6 -> DF+AL, 7 -> FC+AL, 8 -> CW+AL, 9 -> SUPS+AL	2.60+
30	Heating steps	2 - 3 (only if 2 el. heaters are installed)	2.60+
31	Valve running time	50 - 500; [s]	2.60+
32	Temperature-sensor-offset	-50 - 50; [1/10 K]	2.60+
33	Humidity-sensor-offset	-99 - 99; [%RH]	2.60+
34	Humidifier supply voltage	1 -> 240V, 2 -> 380V, 3 -> 460V, 4 -> 575V	2.60+
35	Humidifier model	1 -> 21L, 2 -> 51L, 3 -> 51H, 4 -> 93L, 5 -> 93H, 6 -> Ext	2.60+
36	Humidifier steam output	0->No Humidification, 1 -> 30%, 2 -> 40%, 3 -> 50%, 4 -> 60%, 5 -> 70%, 6 -> 80%, 7 -> 90%, 8 -> 100%	2.60+
37	Auto-restart time	0 -> No auto-restart, 1-60; [s]	2.60+
38	Conditioner working hours	0 - 50000; [h]	2.60+
39	Conditioner working hours maximum	0 - 50000; [h]	2.60+
40	Compressor 1 working hours	0 - 50000; [h]	2.60+
41	Compressor 1 working hours maximum	0 - 50000; [h]	2.60+
42	Compressor 2 working hours	0 - 50000; [h]	2.60+

43	Compressor 2 working hours maximum	0 - 50000; [h]	2.60+
44	Humidifier working hours	0 - 50000; [h]	2.60+
45	Humidifier working hours maximum	0 - 50000; [h]	2.60+
46	Freecooling working hours	0 - 50000; [h]	2.60+
47	Freecooling working hours maximum	0 - 50000; [h]	2.60+
48	Analogue user input 1 0V	-9999 - 9999; [1/10]	2.60+
49	Analogue user input 1 10V	-9999 - 9999; [1/10]	2.60+
50	Analogue user input 1 unit	0 -> %, 1 -> °C, 2 -> V, 3 -> A, 4 -> VA, 5 -> Pa, 6 -> kPa, 7 -> °F, 8 -> psi, 9 -> in.W., 10 -> SET	2.60+
51	Analogue user input 1		2.60+
52	Analogue user input 2 0V	-9999 - 9999; [1/10]	2.60+
53	Analogue user input 2 10V	-9999 - 9999; [1/10]	2.60+
54	Analogue user input 2 unit	0 -> %, 1 -> °C, 2 -> V, 3 -> A, 4 -> VA, 5 -> Pa, 6 -> kPa, 7 -> °F, 8 -> psi, 9 -> in.W., 10 -> SET	2.60+
55	Analogue user input 2		2.60+
56	Sleep mode deadband	255->System off, 2 - 16; [°C]	2.60+
57	Sleep mode days	Bit 0 -> Mon, Bit 1 -> Tue, Bit 2 -> Wed, Bit 3 -> Thu, Bit 4 -> Fri, Bit 5 -> Sat, Bit 6 -> Sun	2.60+
58	Sleep from time 1	Low byte -> min., high byte -> hours	2.60+
59	Sleep until time 1	Low byte -> min., high byte -> hours	2.60+
60	Sleep from time 2	Low byte -> min., high byte -> hours	2.60+
61	Sleep until time 2	Low byte -> min., high byte -> hours	2.60+
62	Language	0 -> English, 1 -> Italian, 2 -> German, 3 -> French, 4 -> Portuguese, 5 -> Spanish, 6 -> Swedish, 7 -> Greek	2.60+
63	Hirosensor #1 Value #1-Offset	-50 - 50; [1/10 K]	2.60+
64	Hirosensor #1 Value #2-Offset	-99 - 99; [%RH] or -50 - 50; [1/10 K]	2.60+
65	Hirosensor #2 Value #1-Offset	-50 - 50; [1/10 K]	2.60+
66	Hirosensor #2 Value #2-Offset	-99 - 99; [%RH] or -50 - 50; [1/10 K]	2.60+
67	EEAP-Sensor Temperature-Offset	-50 - 50; [1/10 K]	2.60+
68	EEAP-Sensor Humidity-Offset	-99 - 99; [%RH]	2.60+
69	Outside-Temperature-Sensor Offset	-50 - 50 K; [1/10 K]	2.60+
70	Glycol-Temperature-Sensor Offset	-50 - 50; [1/10 K]	2.60+
71	Hirosensor #1 installed	0 -> No, 1 -> Humitemp, 2 -> Hirotemp	2.60+
72	Hirosensor #2 installed	0 -> No, 1 -> Humitemp, 2 -> Hirotemp	2.60+
73	EEAP-Sensor #1 installed	0 -> No; 1 -> Yes	2.60+

### Status-Report-Acknowledge (Holding Register #1):

Read the document 'Hirolink for Modbus V X.XX - General Documentation' (X.XX is a placeholder for the current version of the Hirolink) for a description on how to use this data-point.



### 3.4 Input-Register

Register #	Usage	Unit	SW-Version
1	Event-ID	ID identifying the event	2.60+
2	Not used		2.60+
3	Minute	Minute, when event occurred	2.60+
4	Hour	Hour, when event occurred	2.60+
5	Date	Date, when event occurred	2.60+
6	Event-Type	0 -> message, 1 -> warning, 2 -> alarm, 3 -> reset	2.60+
7	System status	See explanation below	2.60+
8	Actual temperature	[1/10 °C]	2.60+
9	Actual humidity	[1/10 %RH]	2.60+
10	Shifted temperature-setpoint	[1/10 °C]	2.60+
11	Shifted humidity-setpoint	[1/10 %RH]	2.60+
12	Temperature setpoint-shifting	[%]	2.60+
13	Humidity setpoint-shifting	[%]	2.60+
14	Actual temperature EEAP	[1/10 °C]	2.60+
15	Actual humidity EEAP	[1/10 %RH]	2.60+
16	Outside temperature	[1/10 °C]	2.60+
17	Glycol temperature	[1/10 %RH]	2.60+
18	Analogue user input 1	[1/10 V]	2.60+
19	Analogue user input 2	[1/10 V]	2.60+
20	Analogue user input 1 recalculated		2.60+
21	Analogue user input 2 recalculated		2.60+
22	Liquistat sensor	[1/100 V]	2.60+
23	Airflow rate sensor	[1/100 V]	2.60+
24	Humidifier current	[1/100 A]	2.60+
25	Cold water ramp 1	[%]	2.60+
26	Cold water ramp 2	[%]	2.60+
27	Hot water ramp	[%]	2.60+
28	Fan control ramp	[%]	2.60+
29	Compressor 1 ramp	[%]	2.60+
30	Compressor 2 ramp	[%]	2.60+
31	Humidifier ramp	[%]	2.60+
32	Hirosensor #1 Value #1	[1/10 °C]	2.60+
33	Hirosensor #1 Value #2	[1/10 %RH] or [1/10 °C]	2.60+
34	Hirosensor #2 Value #1	[1/10 °C]	2.60+
35	Hirosensor #2 Value #2	[1/10 %RH] or [1/10 °C]	2.60+

#### Status-Report-Block (Input Register #1 - #6):

Read the document 'Hirolink for Modbus V X.XX - General Documentation' (X.XX is a placeholder for the current version of the Hirolink) for a description on how to use these data-points.

#### System Status (Input Register #7):

The values of this item correspond to the following system-states:

- 0..System off
- 1..System on
- 2..Manual on
- 3..Remote off
- 4..Remote on
- 5..Sleep mode on

### 3.5 Events

#### **IMPORTANT:**

Read the document 'Hirolink for Modbus V X.XX - General Documentation' (X.XX is a placeholder for the current version of the Hirolink) for a detailed description on how to use these data-points.

In the following list you can see all Events and Event-IDs available for Advanced-Graphic-units:

Event-ID	Event-Description	Event-Type	SW-Version
1	HIGH PRESSURE COMPRESSOR 1, check freon circuit + condenser	Alarm	2.60+
2	LOW PRESSURE COMPRESSOR 1, check freon circuit	Alarm	2.60+
3	EL. PROTECTION COMPRESSOR 1, check freon circuit + condenser	Alarm	2.60+
4	NOT USED		2.60+
5	HIGH PRESSURE COMPRESSOR 2, check freon circuit + condenser	Alarm	2.60+
6	LOW PRESSURE COMPRESSOR 2, check freon circuit	Alarm	2.60+
7	EL. PROTECTION COMPRESSOR 2, check freon circuit + condenser	Alarm	2.60+
8	NOT USED		2.60+
9	NOT USED		2.60+
10	CHILLED WATER TEMP. TOO HIGH FOR SAFE OPERATION	Warning	2.60+
11	CHILLED WATER FLOW TOO LOW FOR SAFE OPERATION	Warning	2.60+
12	EL. HEATERS OVERHEATING, check fans and sensors	Alarm	2.60+
13	LOSS OF AIR FLOW, check fans	Warning	2.60+
14	CLOGGED FILTERS, check air filters	Warning	2.60+
15	SMOKE/FIRE DETECTION Unit stopped	Alarm	2.60+
16	WATER LEAKAGE DETECTION, check hydraulic circuit	Alarm	2.60+
17	USER INPUT #1 TRIGGERED	Warning	2.60+
18	USER INPUT #2 TRIGGERED	Warning	2.60+
19	AUTORESTORE SETTINGS	Message	2.60+
20	HUMIDIFIER FAILURE	Alarm	2.60+
21	HUMIDIFIER SHORT CIRCUIT, check el. circuit + cylinder	Warning	2.60+
22	HUMIDIFIER HIGH CURRENT, check cylinder	Alarm	2.60+
23	HUMIDIFIER MAINS FAILURE, check electrical circuit	Alarm	2.60+
24	HUMIDIFIER WITHOUT WATER, check water supply	Warning	2.60+
25	HUMIDIFIER CYLINDER WORN, please replace	Warning	2.60+
26	LOSS OF AIR FLOW, check fans	Alarm	2.60+
27	USER INPUT #1 TRIGGERED	Alarm	2.60+
28	USER INPUT #2 TRIGGERED	Alarm	2.60+
29	PARAMETER CORRECTION	Message	2.60+
30	HIGH ROOM TEMPERATURE	Warning	2.60+
31	LOW ROOM TEMPERATURE	Warning	2.60+
32	HIGH ROOM HUMIDITY	Warning	2.60+
33	LOW ROOM HUMIDITY	Warning	2.60+
34	HIGH ROOM TEMPERATURE SENSED BY EEAP	Alarm	2.60+

35	LOW ROOM TEMPERATURE SENSED BY EEAP	Alarm	2.60+
36	HIGH ROOM HUMIDITY SENSED BY EEAP	Alarm	2.60+
37	LOW ROOM HUMIDITY SENSED BY EEAP	Alarm	2.60+
38	USERSETTINGS RESTORED	Message	2.60+
39	ROMSETTINGS RESTORED	Message	2.60+
40	CONDITIONER WORKING HOURS THRESHOLD EXCEEDED	Warning	2.60+
41	COMPRESSOR 1 WORKING HOURS THRESHOLD EXCEEDED	Warning	2.60+
42	COMPRESSOR 2 WORKING HOURS THRESHOLD EXCEEDED	Warning	2.60+
43	HUMIDIFIER WORKING HOURS THRESHOLD EXCEEDED	Warning	2.60+
44	HUMIDIFICATION EXTERNALLY DISABLED	Message	2.60+
45	HUMIDIFICATION EXTERNALLY ENABLED	Message	2.60+
46	HIROSENSOR #1 FAILURE, please replace sensor	Warning	2.60+
47	HIROSENSOR #2 FAILURE, please replace sensor	Warning	2.60+
48	USERSETTINGS STORED	Message	2.60+
49	MANUAL MODE	Message	2.60+
50	POWER RESTORED	Reset	2.60+
51	POWER OFF	Message	2.60+
52	SYSTEM ON	Message	2.60+
53	SYSTEM OFF	Message	2.60+
54	REMOTE ON	Message	2.60+
55	REMOTE OFF	Message	2.60+
56	ALARM RESET	Reset	2.60+
57	ALARM ACKNOWLEDGED	Message	2.60+
58	SLEEP MODE ON	Message	2.60+
59	SLEEP MODE OFF	Message	2.60+
60	RAM ERROR, replace display board	Alarm	2.60+
61	EPROM ERROR, please replace eprom	Alarm	2.60+
62	EEPROM ERROR, replace display board	Alarm	2.60+
63	DISPLAY BOARD FAILURE, please replace	Alarm	2.60+
64	INTERFACE BOARD ERROR, please replace	Alarm	2.60+
65	ROOM SENSOR FAILURE, please replace sensor	Alarm	2.60+
66	EEAP SENSOR FAILURE, please replace sensor	Warning	2.60+
67	WATER PRESENCE SENSOR FAILURE, check wiring	Warning	2.60+
68	FILTER PRESSURE DROP SENSOR FAILURE	Warning	2.60+
69	PRINTING IMPOSSIBLE, check connections	Warning	2.60+
70	DISPLAY BOARD FAILURE X please replace	Alarm	2.60+
71	LOCAL ON/OFF DISABLED	Warning	2.60+
72	SLEEP MODE EXTERNALLY DISABLED	Message	2.60+
73	SLEEP MODE EXTERNALLY ENABLED	Message	2.60+
74	UNIT UNDER HIROVISOR CONTROL	Warning	2.60+
100	UNIT CONNECTED	Message	2.60+
101	UNIT NOT CONNECTED	Message	2.60+

## 4. Document-Changes

This appendix contains all changes that have been applied to this document up to the current version:

### 1. Changes from V 1.00 to V 1.01

All descriptions regarding the 'Status-Report' have been moved to the document 'Hirolink for Modbus V X.XX - General Documentation' (X.XX is a placeholder for the current version of the Hirolink).

## Connectivity



*the evolution*

## Hirolink for Modbus

(05) Items for CAM (GCAM) (Macroface).doc

English

04/11/03 Release 1.01E

<b>1.</b>	<b>INTRODUCTION CAM (GCAM) (MACROFACE)</b> .....	<b>2</b>
<b>2.</b>	<b>COMPATIBILITY-LIST</b> .....	<b>2</b>
<b>3.</b>	<b>ITEMS FOR HIROMATIC-TYPE CAM (MACROFACE)</b> .....	<b>2</b>
3.1	COILS .....	2
3.2	INPUT-STATUS .....	2
3.3	HOLDING REGISTER .....	2
3.4	INPUT-REGISTER.....	2
3.5	EVENTS .....	2
<b>4.</b>	<b>DOCUMENT-CHANGES</b> .....	<b>2</b>

# 1. Introduction CAM (GCAM) (Macroface)

This document contains a description of all data-points that are available via the 'Hirolink for Modbus' from this type of air-conditioner.

## **IMPORTANT:**

It is vital to the correct integration of the Hirolink into a Modbus-network, that you have read and understood the topics described in the document 'Hirolink for Modbus V X.XX - General Documentation' (X.XX is a placeholder for the current version of the Hirolink). So, if you haven't read this document until now, read it first.

## 2. Compatibility-List

Before connecting a Hiromatic to the Modbus-Hirolink you must check, if the Hiromatic-software-version is compatible with this version of the Hirolink.

You can do this by checking the labels on the eproms, which are inserted into the Hiromatic and the Macroface. The eprom inserted in the Hiromatic must be called GCAM + Version-Number (e.g. GCAM260) and the one inserted in the Macroface must be called MCAM + Version-Number (e.g. MCAM260).

To make sure that the label on the eproms is correct, you should also check the version-information, that the Hiromatic displays shortly after start-up. This information should look similar to the following illustration:

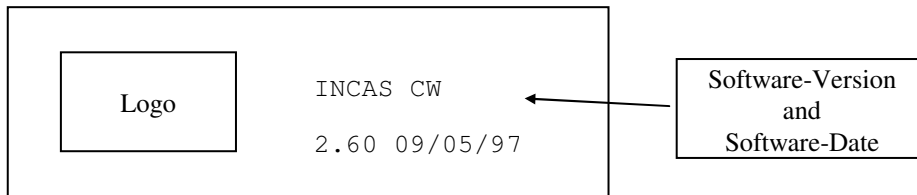

The important information in this window is only the software-version and the software-date. Make sure that the software-version installed in your installation matches one of the compatible versions listed below:

<b>Version</b>	<b>Date</b>
2.60	09/05/97
2.61	16/07/97
2.62	16/08/97
2.63	16/10/97
2.64	31/10/97

### 3. Items for Hiromatic-Type CAM (Macroface)

According to the Modbus-protocol-specifications the values and parameters provided by the Hiromatic are represented in 4 groups:

- Coils: Used for changeable, digital values
- Inputs: Used for not changeable, digital values
- Holding Registers: Used for changeable, analog values
- Input Registers: Used for not changeable, analog values

This Hirolink can be compatible with more than one version of this Hiromatic-type and it is possible that there have been extensions in the number of available items from one version to the next.

Therefore the column 'SW-Version' contained in the following lists provides information about the availability of each item depending on the Hiromatic-software-version. For example a entry like '2.60+' means, that this item is available from Hiromatics with software-version 2.60 and higher.

#### **IMPORTANT:**

The available data-points shown in the following chapters are numbered starting from 1, according to the Modbus-Protocol-Specification. Still some BMS start numbering the data-points from 0. So, in case that the BMS you are using starts numbering from 0, you have to decrease the listed numbers by 1.

#### **3.1 Coils**

Coil #	Usage	SW-Version
1	Set system off for all MFs (Command)	2.60+
2	Set system on for all MFs (Command)	2.60+
3	Not used	2.60+
4	Not used	2.60+
5	Set alarm acknowledge (Command)	2.60+
6	Set alarm reset (Command)	2.60+
7	Set standard-settings for all MFs (Command)	2.60+
8	Not used	2.60+
9	Set system off for MF 1 (Command)	2.60+
10	Set system on for MF 1 (Command)	2.60+
11	Not used	2.60+
12	Not used	2.60+
13	Not used	2.60+
14	Not used	2.60+
15	Set standard-settings for MF 1 (Command)	2.60+
16	Not used	2.60+



The items 9-16 are repeated for each MF on the CAM-System:

Items 17-24:	MF 2	Items 81-88:	MF 10
Items 25-32:	MF 3	Items 89-96:	MF 11
Items 33-40:	MF 4	Items 97-104:	MF 12
Items 41-48:	MF 5	Items 105-112:	MF 13
Items 49-56:	MF 6	Items 113-120:	MF 14
Items 57-64:	MF 7	Items 121-128:	MF 15
Items 65-72:	MF 8	Items 129-136:	MF 16
Items 73-80:	MF 9		

Coil #	Usage	SW-Version
137	Not used	2.60+
138	Simultaneous HW and electrical heat for MF 1	2.60+
139	Electrical heating installed for MF 1	2.60+
140	Zone setpoint potentiometer installed for MF 1	2.60+
141	Water leakage detector installed for MF 1	2.60+
142	User input 1 warning/alarm for MF 1	2.60+
143	User input 2 warning/alarm for MF 1	2.60+
144	Single coil unit for MF 1	2.60+

The items 137-144 are repeated for each MF on the CAM-System:

Items 145-152:	MF 2	Items 209-216:	MF 10
Items 153-160:	MF 3	Items 217-224:	MF 11
Items 161-168:	MF 4	Items 225-232:	MF 12
Items 169-176:	MF 5	Items 233-240:	MF 13
Items 177-184:	MF 6	Items 241-248:	MF 14
Items 185-192:	MF 7	Items 249-256:	MF 15
Items 193-200:	MF 8	Items 257-264:	MF 16
Items 201-208:	MF 9		

**IMPORTANT:**

Read the document 'Hirolink for Modbus V X.XX - General Documentation' (X.XX is a placeholder for the current version of the Hirolink) for a description on how to use the coils marked with 'Command'.

**3.2 Input-Status**

Input-Status #	Usage	SW-Version
1	System on MF 1	2.60+
2	Manual on MF 1	2.60+
3	Standby MF 1	2.60+
4	Timer active MF 1	2.60+
5	Ext. remote on MF 1	2.60+
6	Ext. remote on x minutes MF 1	2.60+
7	Ext. standby on MF 1	2.60+
8	Standard-Settings active MF 1	2.60+

The items 1-8 are repeated for each MF on the CAM-System:

Items 9-16:	MF 2	Items 73-80:	MF 10
Items 17-24:	MF 3	Items 81-88:	MF 11
Items 25-32:	MF 4	Items 89-96:	MF 12
Items 33-40:	MF 5	Items 97-104:	MF 13
Items 41-48:	MF 6	Items 105-112:	MF 14
Items 49-56:	MF 7	Items 113-120:	MF 15
Items 57-64:	MF 8	Items 121-128:	MF 16
Items 65-72:	MF 9		

Input-Status #	Usage	SW-Version
129	Alarm MF 1	2.60+
130	Warning MF 1	2.60+
131	Alarm system off MF 1	2.60+
132	Alarm off MF 1	2.60+
133	Timer-switch MF 1	2.60+
134	Not used	2.60+
135	Not used	2.60+
136	Not used	2.60+

The items 129-136 are repeated for each MF on the CAM-System:

Items 137-144:	MF 2	Items 201-208:	MF 10
Items 145-152:	MF 3	Items 209-216:	MF 11
Items 153-160:	MF 4	Items 217-224:	MF 12
Items 161-168:	MF 5	Items 225-232:	MF 13
Items 169-176:	MF 6	Items 233-240:	MF 14
Items 177-184:	MF 7	Items 241-248:	MF 15
Items 185-192:	MF 8	Items 249-256:	MF 16
Items 193-200:	MF 9		

Input-Status #	Usage	SW-Version
257	Status fan 1 MF 1	2.60+
258	Status fan 2 MF 1	2.60+
259	Status fan 3 MF 1	2.60+
260	Status open CW MF 1	2.60+
261	Status close CW MF 1	2.60+
262	Status open HW MF 1	2.60+
263	Status close HW MF 1	2.60+
264	Status dehumidification MF 1	2.60+

The items 257-264 are repeated for each MF the CAM-System:

Items 265-272:	MF 2	Items 329-336:	MF 10
Items 273-280:	MF 3	Items 337-344:	MF 11
Items 281-288:	MF 4	Items 345-352:	MF 12
Items 289-296:	MF 5	Items 353-360:	MF 13
Items 297-304:	MF 6	Items 361-368:	MF 14
Items 305-312:	MF 7	Items 369-376:	MF 15
Items 313-320:	MF 8	Items 377-384:	MF 16
Items 321-328:	MF 9		

Input-Status #	Usage	SW-Version
385	Not used	2.60+
386	Hot water heater MF 1	2.60+
387	El. heater 1 MF 1	2.60+
388	El. heater 2 MF 1	2.60+
389	Humidifier boiler MF 1	2.60+
390	Humidifier feed MF 1	2.60+
391	Humidifier drain MF 1	2.60+
392	Not used	2.60+

The items 385-392 are repeated for each MF on the CAM-System:

Items 393-400:	MF 2	Items 457-464:	MF 10
Items 401-408:	MF 3	Items 465-472:	MF 11
Items 409-416:	MF 4	Items 473-480:	MF 12
Items 417-424:	MF 5	Items 481-488:	MF 13
Items 425-432:	MF 6	Items 489-496:	MF 14
Items 433-440:	MF 7	Items 497-504:	MF 15
Items 441-448:	MF 8	Items 505-512:	MF 16
Items 449-456:	MF 9		

Input-Status #	Usage	SW-Version
513	Remote on/off for MF 1	2.60+
514	Remote on x minutes for MF 1	2.60+
515	Standby for MF 1	2.60+
516	Not used	2.60+
517	Id 1 for MF 1	2.60+
518	Id 2 for MF 1	2.60+
519	Id 4 for MF 1	2.60+
520	Id 8 for MF 1	2.60+

The items 513-520 are repeated for each MF on the CAM-System:

Items 521-528:	MF 2	Items 585-592:	MF 10
Items 529-536:	MF 3	Items 593-600:	MF 11
Items 537-544:	MF 4	Items 601-608:	MF 12
Items 545-552:	MF 5	Items 609-616:	MF 13
Items 553-560:	MF 6	Items 617-624:	MF 14
Items 561-568:	MF 7	Items 625-632:	MF 15
Items 569-576:	MF 8	Items 633-640:	MF 16
Items 577-584:	MF 9		

Input-Status #	Usage	SW-Version
641	Hot water ok for MF 1	2.60+
642	Heater safety for MF 1	2.60+
643	Fire and smoke alarm for MF 1	2.60+
644	Clogged filter for MF 1	2.60+
645	Fan failure for MF 1	2.60+
646	User input 1 for MF 1	2.60+
647	User input 2 for MF 1	2.60+
648	Humidifier level for MF 1	2.60+

The items 641-648 are repeated for each MF on the CAM-System:

Items 649-656:	MF 2	Items 713-720:	MF 10
Items 657-664:	MF 3	Items 721-728:	MF 11
Items 665-672:	MF 4	Items 729-736:	MF 12
Items 673-680:	MF 5	Items 737-744:	MF 13
Items 681-688:	MF 6	Items 745-752:	MF 14
Items 689-696:	MF 7	Items 753-760:	MF 15
Items 697-704:	MF 8	Items 761-768:	MF 16
Items 705-712:	MF 9		

### 3.3 Holding Register

Register #	Usage	Range; Unit	SW-Version
1	Status-Report-Acknowledge	See description below	2.60+
2	HM-Status	Bit 0..C/F, Bit 2..Shared Parameters	2.60+
3	Language	0 -> English, 1 -> Italian, 2 -> German, 3 -> French, 4 -> Portuguese	2.60+
4	Number of Macrofaces	1 - 16	2.60+
5	Read xTU temperatures	see description below	2.60+
6	Write xTU setpoint	see description below	2.60+
7	Read / write xTU setup	see description below	2.60+
8	Read / write xTU offsets	see description below	2.60+
9	xTU setpoint	180 - 280; [1/10 °C]	2.60+
10	xTU-Id for xTU-setup write	0 - 31	2.60+
11	Set xTU-Id for xTU-setup read / write	0 - 31	2.60+
12	Set xTU-sub-Id for xTU-setup read / write	0 - 7	2.60+
13	Set xTU-type for xTU-setup read / write	0 -> FAT, 1 -> xTU	2.60+
14	xTU temperature offset 1	0 - 99	2.60+
15	xTU temperature offset 2	0 - 99	2.60+
16	xTU Id for temperature offsets read / write	0 - 31	2.60+
17	xTU setup master Id	0 - 31	2.60+
18	xTU setup slave Id	0 - 7	2.60+
19	xTU setup type	0 -> FAT, 1 -> xTU	2.60+
20	xTU setup fan speed offset	0 - 9	2.60+
21	xTU setup fan speed control	0 -> Y, 1 -> N, 2 -> D	2.60+
22	xTU setup fan speed	0 - 30	2.60+
23	xTU setup heater delay	0 - 32	2.60+
24	xTU setup temperature control	0, 1 -> U	2.60+
25	xTU setup reading interval (only Flyboard)	0 - 60; [sec]	2.60+
26	xTU setup reading time (only Flyboard)	0 - 200; [sec]	2.60+
27	xTU setup valid	0 -> not valid, 1 -> valid	2.60+
28-43	Autorestart after power on	0 -> No, 0 - 60; [sec]	2.60+
44-59	Delay xTu's on	0 - 240; [min]	2.60+
60-75	Delay xTu's off	0 - 240; [min]	2.60+
76-91	Fanspeed	0 -> LOW, 1 -> NORMAL, 2 -> HIGH	2.60+
92-107	xTu's connected	0 - 31	2.60+
108-123	xTu's ignored	0 - 31	2.60+
124-139	xTu setpoint range	0 - 10; [K]	2.60+
140-155	Zone setpoint	180 - 280; [1/10 °C]	2.60+
156-171	Zone setpoint range min.	12 - 32; [°C]	2.60+
172-187	Zone setpoint range max.	12 - 32; [°C]	2.60+
188-203	Room integration factor	0 - 9999; [sec]	2.60+
204-219	Supply air setpoint	0 - 500; [1/10 °C]	2.60+
220-235	Supply air comp. Factor	0 - 200; [1/10]	2.60+
236-251	Cooling proportional band	10 - 100; [1/10 K]	2.60+
252-267	Heating proportional band	10 - 100; [1/10 K]	2.60+
268-283	Supply air dead band	00 - 100; [1/10 K]	2.60+
284-299	Supply air integration factor	0 - 9999; [sec]	2.60+
300-315	Summer compensation setpoint	15 - 45; [°C]	2.60+
316-331	Winter compensation setpoint	-10 - 25; [°C]	2.60+
332-347	Summer compensation factor	-10 - 10; [1/10 °C]	2.60+
348-363	Winter compensation factor	-10 - 10; [1/10 °C]	2.60+
364-379	Supply air set min.	5 - 25; [°C]	2.60+
380-395	Supply air set max.	25 - 50; [°C]	2.60+
396-411	Priority of sensor 1 to sensor 2	0 - 100; [%]	2.60+

412-427	Priority of sensor 3 to sensor 4	0 - 100; [%]	2.60+
428-443	Outdoor compensation enabled	0 -> No, 1 -> Yes	2.60+
444-459	Room humidity setpoint	35 - 75; [%rH]	2.60+
460-475	Humidity band humidification	2 - 20; [%rH]	2.60+
476-491	Humidity band dehumidification	2 - 20; [%rH]	2.60+
492-507	Humidifier production rate	0 -> 0%, 1 -> 30%, 2 -> 40%, 3 -> 50%, 4 -> 60 %, 5 -> 70 %, 6 -> 80 %, 7 -> 90 %, 8 -> 100%	2.60+
508-523	Humidifier model	1 -> 21L, 2 -> 53L, 3 -> 53H, 4 -> 93L, 5 -> 93H, 6 -> EXT	2.60+
524-539	Humidifier supply voltage	1 -> 240V, 2 -> 380V, 3 -> 460V, 4 -> 575V	2.60+
540-555	Humidifier control type	0 -> PROP., 1 -> ON/OFF	2.60+
556-571	Low fan speed set to	0 - 100; [%]	2.60+
572-587	Medium fan speed set to	0 - 100; [%]	2.60+
588-603	High fan speed set to	0 - 100; [%]	2.60+
604-619	Air volume reduction allowed	0 -> No, 1 -> Yes	2.60+
620-635	xTU group A NA	0 - 31	2.60+
636-651	xTU group B NB	0 - 31	2.60+
652-667	xTU group C NC	0 - 31	2.60+
668-683	xTU group D ND	0 - 31	2.60+
684-699	xTU group A KPA	0 - 25; [1/10]	2.60+
700-715	xTU group B KPB	0 - 25; [1/10]	2.60+
716-731	xTU group C KPC	0 - 25; [1/10]	2.60+
732-747	xTU group D KPD	0 - 25; [1/10]	2.60+
748-763	Default speed	0 -> Low, 1-> Normal	2.60+
764-779	Unit type	0 -> CAM, 1 -> HIVAR	2.60+
780-795	Timer function enabled	0 -> No, 1-> Yes	2.60+
796-811	Number of sensors connected	1 - 4	2.60+
812-827	CW valve running time	50 - 500; [sec]	2.60+
828-843	HW valve running time	50 - 500; [sec]	2.60+
844-859	Low airflow warning at	0 - 100; [%]	2.60+
860-875	Local override unit on	0 - 120; [min]	2.60+
876-891	High room temperature	25 - 40; [°C]	2.60+
892-907	Low room temperature	0 - 25; [°C]	2.60+
908-923	High supply air temperature	25 - 55; [°C]	2.60+
924-939	Low supply air temperature	0 - 25; [°C]	2.60+
940-955	High room humidity	30 - 99; [%rH]	2.60+
956-971	Low room humidity	10 - 70; [%rH]	2.60+
972-987	Room-Sensor 1 temperature offset	-99 - 99; [1/10 °C]	2.60+
988-1003	Room-Sensor 2 temperature offset	-99 - 99; [1/10 °C]	2.60+
1004-1019	Room-Sensor 3 temperature offset	-99 - 99; [1/10 °C]	2.60+
1020-1035	Room-Sensor 4 temperature offset	-99 - 99; [1/10 °C]	2.60+
1036-1051	PTCB temperature 2 offset	-99 - 99; [1/10 °C]	2.60+
1052-1067	Ext. sensor temperature offset	-99 - 99; [1/10 °C]	2.60+
1068-1083	Room-Sensor 2 humidity offset	-99 - 99; [1/10 %rH]	2.60+
1084-1099	Room-Sensor 3 humidity offset	-99 - 99; [1/10 %rH]	2.60+
1100-1115	Room-Sensor 4 humidity offset	-99 - 99; [1/10 %rH]	2.60+

### Status-Report-Acknowledge (Holding Register #1):

Read the document 'Hirolink for Modbus V X.XX - General Documentation' (X.XX is a placeholder for the current version of the Hirolink) for a description on how to use this data-point.

## Reading the xTU-temperatures:

You have to write the MF-ID from which you want to read the xTU-temperatures to Holding Register #5. This will cause the Input Registers #7-99 to be filled with the appropriate xTU-temperatures.

## Writing the xTU-setpoints:

First you have to write the desired setpoint-value to Holding Register #9 and the xTU-ID to which you want to send the setpoint to Holding Register #10.

After that, you have to write the MF-ID to which the xTU is connected to Holding Register #6, with 128 added to this value.

For example:

You want to set the setpoint of xTU #5, connected to MF #4 to 23,0 °C:

1. Write 230 to Holding Register #9.
2. Write 5 to Holding Register #10.
3. Write 132 (= 4 + 128) to Holding Register #6.

## Reading the xTU-setup:

To read the setup of one xTU, you have to set the following values:

Holding Register #7 -> MF-ID to which the xTU is connected  
Holding Register #11 -> Master-ID of the xTU  
Holding Register #12 -> Slave-ID of the xTU  
Holding Register #13 -> xTU-Type

After that, the Holding Registers #17-#26 will be filled with the appropriate values, where Holding Register #27 shows, if the values are valid. As long as Holding Register #27 is 0, you should keep writing the MF-ID to Holding Register #7. When the values are valid Holding Register #27 will change to 1.

## Writing the xTU-setup:

To write the setup of one xTU, you have to set the following values:

Holding Register #11 -> Master-ID of the xTU  
Holding Register #12 -> Slave-ID of the xTU  
Holding Register #13 -> xTU-Type  
Holding Register #17-26: xTU-setup

After that, you have to write the MF-ID to which the xTU is connected to Holding Register #7, with 128 added to this value (see also 'Writing the xTU-setpoints').

## Reading the xTU-offsets:

You have to write the MF-ID from which you want to read the xTU-temperatures to Holding Register #8. This will cause the Input Registers #100-161 to be filled with the appropriate xTU-offsets.

The real offset-value is calculated as follows:

Offset-Value = Register-Value - 50

For example:

Register-Value = 0 -> Offset = -5.0 K  
Register-Value = 50 -> Offset = -0 K  
Register-Value = 99 -> Offset = 4.9 K

## Writing the xTU-offsets:

To write the offsets of one xTU, you have to set the following values:

Holding Register #14,#15 -> xTU-offsets  
Holding Register #16 -> xTU-ID

After that, you have to write the MF-ID to which the xTU is connected to Holding Register #8, with 128 added to this value (see also 'Writing the xTU-setpoints').

The real offset-value has to be calculated in the same way as when reading the offsets.

### 3.4 Input-Register

Register #	Usage	Unit	SW-Version
1	Event-ID	ID identifying the event	2.60+
2	Controller-ID	Controller-ID, where the event occurred	2.60+
3	Minute	Minute, when event occurred	2.60+
4	Hour	Hour, when event occurred	2.60+
5	Date	Date, when event occurred	2.60+
6	Event-Type	0 -> message, 1 -> warning, 2 -> alarm, 3 -> reset	2.60+

#### Status-Report-Block (Input Register #1 - #6):

Read the document 'Hirolink for Modbus V X.XX - General Documentation' (X.XX is a placeholder for the current version of the Hirolink) for a description on how to use these data-points.

Register #	Usage	Unit	SW-Version
7	Temperature setpoint for xTU 1	[1/10 °C]	2.60+
8	Temperature #1 for xTU 1	[1/10 °C]	2.60+
9	Temperature #2 for xTU 1	[1/10 °C]	2.60+

The items 7-9 are repeated for each possible xTU:

Items 10-12: xTU 2  
 Items 13-15: xTU 3  
 Items 16-18: xTU 4  
 Items 19-21: xTU 5  
 Items 22-24: xTU 6  
 Items 25-27: xTU 7  
 Items 28-30: xTU 8  
 Items 31-33: xTU 9  
 Items 34-36: xTU 10  
 Items 37-39: xTU 11  
 Items 40-42: xTU 12  
 Items 43-45: xTU 13  
 Items 46-48: xTU 14  
 Items 49-51: xTU 15  
 Items 52-54: xTU 16  
 Items 55-57: xTU 17  
 Items 58-60: xTU 18  
 Items 61-63: xTU 19  
 Items 64-66: xTU 20  
 Items 67-69: xTU 21  
 Items 70-72: xTU 22  
 Items 73-75: xTU 23  
 Items 76-78: xTU 24  
 Items 79-81: xTU 25  
 Items 82-84: xTU 26  
 Items 85-87: xTU 27  
 Items 88-90: xTU 28  
 Items 91-93: xTU 29  
 Items 94-96: xTU 30  
 Items 97-99: xTU 31



Register #	Usage	Unit	SW-Version
100-130	Temperature #1 offset (xTU 1 - xTU 31)	[1/10 K]	2.60+
131-161	Temperature #2 offset (xTU 1 - xTU 31)	[1/10 K]	2.60+
162-177	Room temperature (MF 1-16)	[1/10 °C]	2.60+
178-193	Setpoint (MF 1-16)	[1/10 °C]	2.60+
194-209	Room humidity (MF 1-16)	[1/10 %rH]	2.60+
210-225	Coldwater valve (MF 1-16)	[1 %]	2.60+
226-241	Hotwater valve (MF 1-16)	[1 %]	2.60+
242-257	Room-Sensor 1 temperature (MF 1-16)	[1/10 °C]	2.60+
258-273	Room-Sensor 2 temperature (MF 1-16)	[1/10 °C]	2.60+
274-289	Room-Sensor 3 temperature (MF 1-16)	[1/10 °C]	2.60+
290-305	Room-Sensor 4 temperature (MF 1-16)	[1/10 °C]	2.60+
306-321	Room-Sensor 2 humidity (MF 1-16)	[1/10 %rH]	2.60+
322-337	Room-Sensor 3 humidity (MF 1-16)	[1/10 %rH]	2.60+
338-353	Room-Sensor 4 humidity (MF 1-16)	[1/10 %rH]	2.60+
354-369	Supply air operating setpoint (MF 1-16)	[1/10 °C]	2.60+
370-385	Supply air temperature (MF 1-16)	[1/10 °C]	2.60+
386-401	Outdoor temperature (MF 1-16)	[1/10 °C]	2.60+
402-417	Airflow rate sensor (MF 1-16)	[1/10 V]	2.60+
418-433	Liquistat sensor (MF 1-16)	[1/100 V]	2.60+
434-449	Zone setpoint potentiometer (MF 1-16)	[1/50 V]	2.60+
450-465	Humidifier current (MF 1-16)	[1/100 A]	2.60+
466-481	System status 1 (MF 1-16)	see description below	2.60+
482-497	System status 2 (MF 1-16)	see description below	2.60+

#### System-Status 1 (Input Register #466 - #481):

These items hold a value, which represents the current state of the single Macrofaces. The values correspond to the following states:

- 0 .... System off
- 1 .... System on
- 2 .... Manual on
- 3 .... Remote off
- 4 .... Remote on
- 5 .... Standby

#### System-Status 2 (Input Register #482 - #497):

These items hold a value, which represents the current state of the single Macrofaces in form of single bits. The values correspond to the following states:

- Bit 0 ... Alarm active
- Bit 1 ... Warning active
- Bit 2 ... Acknowledge active
- Bit 3 ... Manual drain active
- Bit 4 ... Standardsettings active
- Bit 5 ... Not used
- Bit 6 ... Not used
- Bit 7 ... Not used

### 3.5 Events

#### **IMPORTANT:**

Read the document 'Hirolink for Modbus V X.XX - General Documentation' (X.XX is a placeholder for the current version of the Hirolink) for a detailed description on how to use these data-points.

In the following list you can see all Events and Event-IDs available for CAM-units:

Event-ID	Event-Description	Event-Type	SW-Version
1	PARAMETER CORRECTION	Message	2.61+
2	ERROR WRITING TO EEPROM	Alarm	2.64+
3	NOT USED		2.60+
4	NOT USED		2.60+
5	NOT USED		2.60+
6	NOT USED		2.60+
7	NOT USED		2.60+
8	NOT USED		2.60+
9	NOT USED		2.60+
10	NOT USED		2.60+
11	NOT USED		2.60+
12	EL. HEATERS OVERHEATING, check fans and sensors	Alarm	2.60+
13	LOSS OF AIR FLOW, check fans	Alarm	2.60+
14	CLOGGED FILTERS, check air filters	Warning	2.60+
15	SMOKE/FIRE DETECTION, Unit stopped	Alarm	2.60+
16	WATER LEAKAGE DETECTION, check hydraulic circuit	Alarm	2.60+
17	USER INPUT #1 TRIGGERED	Alarm	2.60+
18	USER INPUT #2 TRIGGERED	Alarm	2.60+
19	NOT USED		2.60+
20	HUMIDIFIER FAILURE	Alarm	2.60+
21	HUMIDIFIER SHORT CIRCUIT, check el. circuit + cylinder	Alarm	2.60+
22	HUMIDIFIER HIGH CURRENT, check cylinder	Alarm	2.60+
23	HUMIDIFIER MAINS FAILURE, check electrical circuit	Alarm	2.60+
24	HUMIDIFIER WITHOUT WATER, check water supply	Warning	2.60+
25	HUMIDIFIER CYLINDER WORN, please replace	Warning	2.60+
26	NOT USED		2.60+
27	NOT USED		2.60+
28	RETURN AIR SENSOR FAILURE, please replace	Warning	2.60+
29	SUPPLY AIR SENSOR FAILURE, please replace	Alarm	2.60+
30	HIGH ROOM TEMPERATURE	Warning	2.60+
31	LOW ROOM TEMPERATURE	Warning	2.60+
32	HIGH ROOM HUMIDITY	Warning	2.60+
33	LOW ROOM HUMIDITY	Warning	2.60+
34	NOT USED		2.60+
35	USER INPUT #1 TRIGGERED	Warning	2.60+
36	USER INPUT #2 TRIGGERED	Warning	2.60+
37	NOT USED		2.60+
38	HIGH SUPPLY TEMPERATURE	Warning	2.60+
39	LOW SUPPLY TEMPERATURE	Warning	2.60+
40	ROOM SENSOR-1 FAILURE, please replace sensor	Alarm	2.60+
41	ROOM SENSOR-2 FAILURE, please replace sensor	Alarm	2.60+
42	ROOM SENSOR-3 FAILURE, please replace sensor	Alarm	2.60+
43	ROOM SENSOR-4 FAILURE, please replace sensor	Alarm	2.60+

44	WATER LEAKAGE DETECTION, CHECK SENSOR 1	Alarm	2.60+
45	WATER LEAKAGE DETECTION, CHECK SENSOR 2	Alarm	2.60+
46	WATER LEAKAGE DETECTION, CHECK SENSOR 3	Alarm	2.60+
47	WATER LEAKAGE DETECTION, CHECK SENSOR 4	Alarm	2.60+
48	WATER LEAKAGE DETECTION, CHECK SENSOR 5	Alarm	2.60+
49	NOT USED		2.60+
50	POWER RESTORED	Reset	2.60+
51	POWER OFF	Message	2.60+
52	SYSTEM ON	Message	2.60+
53	SYSTEM OFF	Message	2.60+
54	UNIT ON	Message	2.60+
55	UNIT OFF	Message	2.60+
56	ALARM RESET	Reset	2.60+
57	ALARM ACKNOWLEDGED	Message	2.60+
58	MANUAL MODE	Message	2.60+
59	STANDBY	Message	2.60+
60	RAM ERROR, replace display board	Alarm	2.60+
61	EPROM ERROR, please replace eprom	Alarm	2.60+
62	EEPROM ERROR	Alarm	2.60+
63	CONTROLLERBOARD FAILURE, please replace	Alarm	2.60+
64	INTERFACE BOARD ERROR, please replace	Alarm	2.60+
65	ROOM SENSOR FAILURE, please replace sensor	Alarm	2.60+
66	NOT USED		2.60+
67	WATER PRESENCE SENSOR FAILURE, check wiring	Warning	2.60+
68	DIFFERENTIAL PRESSURE SENSOR FAILURE, replace	Warning	2.60+
69	OUTDOOR TEMPERATURE SENSOR FAILURE	Warning	2.60+
70	MASTER CONTROLLERBOARD ERROR, more then one	Alarm	2.60+
71	NO MASTER CONTROLLERBOARD	Alarm	2.60+
72	WRONG HARDWARE, please replace interface board	Alarm	2.60+

100	UNIT CONNECTED	Message	2.60+
101	UNIT NOT CONNECTED	Message	2.60+

## 4. Document-Changes

This appendix contains all changes that have been applied to this document up to the current version:

### 1. Changes from V 1.00 to V 1.01

The chapter describing 'Networking Systems' has been removed, because it is now available in the document 'Hirolink for Modbus V X.XX - General Documentation' (X.XX is a placeholder for the current version of the Hirolink).

Also all descriptions regarding the 'Status-Report' have been moved to this document.

## Connectivity



*the evolution*

## Hirolink for Modbus

**(06) Items for Dryer (DRY) (Compact).doc**

**English**

04/11/03 Release 1.04E

1. INTRODUCTION DRYER (DRY) (COMPACT) ..... 2

2. COMPATIBILITY-LIST ..... 2

3. ITEMS FOR DRYER (DRY) (COMPACT) ..... 2

    3.1 COILS..... 2

    3.2 INPUT-STATUS..... 2

    3.3 HOLDING REGISTER..... 2

    3.4 INPUT-REGISTER ..... 2

    3.5 EVENTS..... 2

4. DOCUMENT-CHANGES ..... 2

# 1. Introduction Dryer (DRY) (Compact)

This document contains a description of all data-points that are available via the 'Hirolink for Modbus' from this type of air-conditioner.

## **IMPORTANT:**

It is vital to the correct integration of the Hirolink into a Modbus-network, that you have read and understood the topics described in the document 'Hirolink for Modbus V X.XX - General Documentation' (X.XX is a placeholder for the current version of the Hirolink). So, if you haven't read this document until now, read it first.

## 2. Compatibility-List

Before connecting a Hiromatic to the Modbus-Hirolink you must check, if the Hiromatic-software-version is compatible with this version of the Hirolink.

You can do this by checking the labels on the eprom, which is inserted into the Hiromatic. This eprom must be called DRY + Version-Number (e.g. DRY249B6).

To make sure that the label on the eproms is correct, you should also check the version-information, that the Hiromatic displays shortly after start-up. This information should look similar to the following illustration:

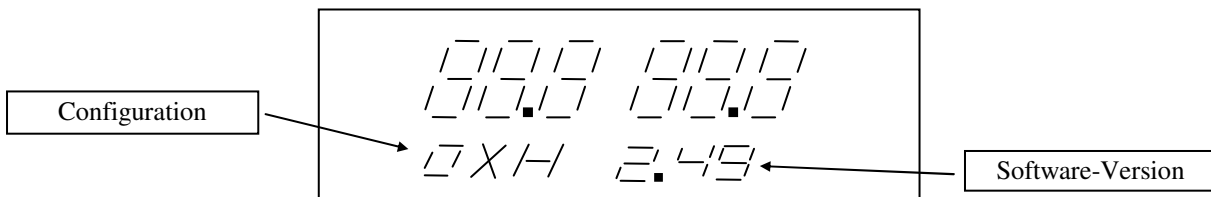

The important information in this window is only the software-version. Make sure that the software-version installed in your installation matches one of the compatible versions listed below:

<b>Version</b>	<b>Date</b>
2.49B6	04.08.1995
2.49B7	25.07.1995
2.49B8	10.04.1996
2.49B9	21.11.1996
2.50	30.03.1998

### 3. Items for Dryer (DRY) (Compact)

According to the Modbus-protocol-specifications the values and parameters provided by the Hiromatic are represented in 4 groups:

- Coils: Used for changeable, digital values
- Inputs: Used for not changeable, digital values
- Holding Registers: Used for changeable, analog values
- Input Registers: Used for not changeable, analog values

This Hirolink can be compatible with more than one version of this Hiromatic-type and it is possible that there have been extensions in the number of available items from one version to the next.

Therefore the column 'SW-Version' contained in the following lists provides information about the availability of each item depending on the Hiromatic-software-version. For example a entry like '2.49+' means, that this item is available from Hiromatics with software-version 2.49 and higher.

#### **IMPORTANT:**

The available data-points shown in the following chapters are numbered starting from 1, according to the Modbus-Protocol-Specification. Still some BMS start numbering the data-points from 0. So, in case that the BMS you are using starts numbering from 0, you have to decrease the listed numbers by 1.

#### **3.1 Coils**

Coil #	Usage	SW-Version
1	Set system off (Command)	2.49+
2	Set system on (Command)	2.49+
3	Set manual drain (Command)	2.49+
4	Set alarm acknowledge (Command)	2.49+
5	Set alarm reset (Command)	2.49+
6	Set standard-settings (Command)	2.49+
7	Not used	2.49+
8	Not used	2.49+
9	User1-Sensor installed	2.49+
10	User2-Sensor installed	2.49+
11	AirOutlet-Sensor installed	2.49+
12	Carter-Sensor installed	2.49+
13	Ambient-Sensor installed	2.49+
14	HotGas installed	2.49+
15	Suctionpressure-Sensor inst.	2.49+
16	Dischargepressure-Sensor inst.	2.49+
17	Not used	2.49+
18	Pressure 0.... BAR/1.....PSI	2.49+
19	Temperature: 0..°F,1.. °C	2.49+
20	Remote off installed	2.49+
21	Oilpressure-Sensor installed	2.49+
22	Standardsettings 1..ON,0..OFF	2.49+
23	Local on/off disabled	2.49+
24	Not used	2.49+
25	Status-Report-Acknowledge	2.49+

**IMPORTANT:**

Read the document 'Hirolink for Modbus V X.XX - General Documentation' (X.XX is a placeholder for the current version of the Hirolink) for a description on how to use the coils marked with 'Command'.

**Status-Report-Acknowledge (Coil #25):**

Read the document 'Hirolink for Modbus V X.XX - General Documentation' (X.XX is a placeholder for the current version of the Hirolink) for a description on how to use this data-point.

**3.2 Input-Status**

Input-Status #	Usage	SW-Version
1	Compressor 1 active	2.49+
2	Compressor 2 active	2.49+
3	Drain1 active	2.49+
4	Drain2 active	2.49+
5	Alarm active 0..ON,1..OFF	2.49+
6	Not used	2.49+
7	Not used	2.49+
8	Not used	2.49+
9	Remote on/off	2.49+
10	High pressure	2.49+
11	Low pressure	2.49+
12	Thermal protection	2.49+
13	Low oilpressure	2.49+
14	Water Drain1 Alarm	2.49+
15	Water Drain2 Alarm	2.49+
16	User/Freeze Alarm	2.49+
17	Comp1 on	2.49+
18	Comp2 on	2.49+
19	Comp3 on	2.49+
20	Comp4 on	2.49+
21	Next stage requested	2.49+
22	Heat2/HotGas 0..33%	2.49+
23	Heat3/HotGas 34..66%	2.49+
24	Heat4/HotGas 67..100%	2.49+
25	Alarm active	2.49+
26	Warning active	2.49+

**3.3 Holding Register**

Register #	Usage	Range; Unit	SW-Version
1	Status-Report-Acknowledge	See description below	2.49+
2	Language	0->ENG, 1->DEU, 2->FRA, 3->ITA, 4->NOR, 5->POL, 6->ESP, 7->DAN, 8->OL, 9->POR, 10->SW	2.49+
3	Autorestarttime	0 -> No autorestart, 1 - 10; [s]	2.49+
4	Air/air drainer duration	1 - 30; [s]	2.49+
5	Evaporator drainer duration	1 - 30; [s]	2.49+
6	Condensation Setpoint	125 - 210; [1/10 bar]	2.49+



7	Evaporation reading filter	0 - 5; [s]	2.49+
8	Minimum ON time for each step	1 - 15; [min]	2.49+
9	Hotgas cycle time	2 - 20; [s]	2.49+
10	Minimum time between each step	0 - 5; [min]	2.49+
11	Partialization proportional band	5 - 50; [1/100 bar]	2.49+
12	Condensation proportional band	8 - 60; [1/10 bar]	2.49+
13	Condensation integration time	0 -> No, 1-30; [min]	2.49+
14	Full capacity force every	0 -> No, 1-8; [h]	2.49+
15	Different. Temperature setpoint	0 - 30; [°C]	2.49+
16	Partialization setpoint	350 - 600; [1/100 bar]	2.49+
17	Evaporation setpoint	350 - 600; [1/100 bar]	2.49+
18	Evaporator drainer frequency	30,40 - 990; [s]	2.49+
19	Air/Air drainer frequency	30,40 - 990; [s]	2.49+
20	Low pressure alarm delay	0 - 10; [min]	2.49+
21	High inlet air temp warning	10 - 99; [°C]	2.49+
22	Low discharge temp. warning	30 - 140; [°C]	2.49+
23	High discharge temp. alarm	30 - 140; [°C]	2.49+
24	Low condensing temp. warning	0 - 70; [°C]	2.49+
25	High condensing temp. warning	0 - 70; [°C]	2.49+
26	Low oil pressure alarm	1 -500; [1/100 bar]	2.49+
27	Low suction pressure warning	350 - 600; [1/100 bar]	2.49+
28	Low suction pressure alarm	350 - 600; [1/100 bar]	2.49+
29	High discharge pressure warning	125 - 260; [1/10 bar]	2.49+
30	High discharge pressure alarm	125 - 260; [1/10 bar]	2.49+
31	High dewpoint temp. warning	-30 - 30; [°C]	2.49+
32	Low dewpoint temp. alarm	-30 - 40; [°C]	2.49+
33	Low suction temp. warning	-30 - 40; [°C]	2.49+
34	Low suction temp. alarm	-30 - 40; [°C]	2.49+
35	High suction temp. alarm	-30 - 40; [°C]	2.49+
36	Firmware	0 -> DXE, 1 -> MDE 2 -> LED, 3 -> BIG	2.49+
37	Number of compressor stages	1 - 4;	2.49+
38	Zeroscale User1/suc.press. sensor	-999 - 999;	2.49+
39	Fullscale User1/suc.press. sensor	-999 - 999;	2.49+
40	Zeroscale User2/dis. press. sensor	-999 - 999;	2.49+
41	Fullscale User2/dis. press. sensor	-999 - 999;	2.49+
42	Zeroscale Oilpress. Sensor	-999 - 999;	2.49+
43	Fullscale Oilpress. sensor	-999 - 999;	2.49+
44	Dewpoint temp. sensor offset	-10 - 10; [°C]	2.49+
45	Inlet-air temp. sensor offset	-10 - 10; [°C]	2.49+
46	Suction temp. sensor offset	-10 - 10; [°C]	2.49+
47	Discharge temp. sensor offset	-10 - 10; [°C]	2.49+
48	Condensing temp. sensor offset	-10 - 10; [°C]	2.49+
49	Outlet-air temp.sensor offset	-10 - 10; [°C]	2.49+
50	Ambient temp. sensor offset	-10 - 10; [°C]	2.49+
51	Carter temp. sensor offset	-10 - 10; [°C]	2.49+
52	Total working hours	0 -> Reset, 0 - 65000; [h]	2.49+
53	Partial working hours	0 -> Reset, 0 - 65000; [h]	2.49+
54	Working hours warning level	0-65000; [h]	2.49+

### Status-Report-Acknowledge (Holding Register #1):

Read the document 'Hirolink for Modbus V X.XX - General Documentation' (X.XX is a placeholder for the current version of the Hirolink) for a description on how to use this data-point.

### 3.4 Input-Register

Register #	Usage	Unit	SW-Version
1	Event-ID	See explanation below	2.49+
2	Not used		2.49+
3	Not used		2.49+
4	Not used		2.49+
5	Not used		2.49+
6	Event-Type	0 -> message, 1-> warning, 2 -> alarm, 3 -> reset	2.49+
7	System status	see explanation below	2.49+
8	Actual Dewpoint temperature	[1/10 °C]	2.49+
9	Actual Inlet-air temperature	[1/10 °C]	2.49+
10	Actual Suction temperature	[1/10 °C]	2.49+
11	Actual Condensing temperature	[1/10 °C]	2.49+
12	Actual Air-outlet temperature	[1/10 °C]	2.49+
13	Actual Differential temperature	[1/10 °C]	2.49+
14	Actual Carter temperature	[1/10 °C]	2.49+
15	Actual Ambient temperature	[1/10 °C]	2.49+
16	Actual Discharge temperature	[1/10 °C]	2.49+
17	Actual Suction pressure	[1/100 bar]	2.49+
18	Actual Discharge pressure	[1/10 bar]	2.49+
19	Actual Oil pressure	[1/10 bar]	2.49+
20	Actual User1 value	0-999	2.49+
21	Actual User2 value	0-999	2.49+
22	Dewpoint temp. (alarm)	[1/10 °C]	2.49+
23	Air-inlet temp (alarm)	[1/10 °C]	2.49+
24	Suc temp. (alarm)	[1/10 °C]	2.49+
25	Discharge temp. (alarm)	[1/10 °C]	2.49+
26	Condensing temp. (alarm)	[1/10 °C]	2.49+
27	Ambient temp. (alarm)	[1/10 °C]	2.49+
28	Suction pressure (alarm)	[bar]	2.49+
29	Discharge pressure (alarm)	[bar]	2.49+
30	Oil pressure (alarm)	[bar]	2.49+
31	Total working hours	[h]	2.49+
32	Last alarm number (which stops unit)	0-80	2.49+

#### Status-Report-Block (Input Register #1 - #6):

Read the document 'Hirolink for Modbus V X.XX - General Documentation' (X.XX is a placeholder for the current version of the Hirolink) for a description on how to use these data-points.

#### NOTE:

There is an exception to the rule to use in order to check if any more status-report-entries have to be read from the Hirolink. In case of a Dryer-unit, the way for the Modbus-master to check, if more status-report-entries are available, is to check the 'Event-ID'- AND the 'Event-Type'-Register for 0. Only if both registers are 0, the Modbus-master can be sure that all status-report-entries have been read.

#### System Status (Input Register #7):

The values of this item correspond to the following system-states:

- 0..System off
- 1..System on
- 2..Manual on
- 3..Remote off
- 4..Remote on

## Input Register #22 - #32:

These Input Registers show the last values before the unit was stopped, because of an alarm.

### 3.5 Events

#### **IMPORTANT:**

Read the document 'Hirolink for Modbus V X.XX - General Documentation' (X.XX is a placeholder for the current version of the Hirolink) for a detailed description on how to use these data-points.

In the following list you can see all Events and Event-IDs available for Dryer-units:

Event-ID	Event-Description	Event-Type	SW-Version
0	HIGH DEWPOINT TEMPERATURE	Warning	2.49+
1	LOW DEWPOINT TEMPERATURE	Alarm	2.49+
2	HIGH AIR INLET TEMPERATURE	Warning	2.49+
3	LOW FREON SUCTION TEMPERATURE	Warning	2.49+
4	LOW FREON SUCTION TEMPERATURE	Alarm	2.49+
5	HIGH FREON SUCTION TEMPERATURE	Alarm	2.49+
6	LOW FREON DISCHARGE TEMPERATURE	Warning	2.49+
7	HIGH FREON DISCHARGE TEMPERATURE	Alarm	2.49+
8	LOW FREON CONDENSING TEMPERATURE	Warning	2.49+
9	HIGH FREON CONDENSING TEMPERATURE	Warning	2.49+
10	LOW FREON SUCTION PRESSURE	Warning	2.49+
11	LOW FREON SUCTION PRESSURE	Alarm	2.49+
12	HIGH FREON DISCHARGE PRESSURE	Warning	2.49+
13	HIGH FREON DISCHARGE PRESSURE	Alarm	2.49+
14	THERMAL PROTECTION COMPRESSOR	Alarm	2.49+
15	LOW OIL PRESSURE	Alarm	2.49+
16-19	NOT USED		
20	DRAIN 1	Warning	2.49+
21	DRAIN 2	Warning	2.49+
22	USER INPUT	Warning	2.49+
23	USER INPUT	Alarm	2.49+
24-40	NOT USED		
41	WORKING HOURS EXCEEDED	Warning	2.49+
42 - 49	NOT USED	Message	2.49+
50	POWER OFF	Message	2.49+
51	POWER RESTORED	Message	2.49+
52	SYSTEM ON	Message	2.49+
53	SYSTEM OFF	Message	2.49+
54	REMOTE ON	Message	2.49+
55	REMOTE OFF	Message	2.49+
56	ALARM RESET	Message	2.49+
57	ALARM ACKNOWLEDGE	Message	2.49+
58	NOT USED		2.49+
59	NOT USED		2.49+
60	RAM FAILURE	Alarm	2.49+
61	EPROM ERROR	Alarm	2.49+
62	EEPROM ERROR	Alarm	2.49+
63	DISPLAY FAILURE	Alarm	2.49+
64-69	NOT USED		2.49+

70	DEWPOINT TEMPERATURE SENSOR ERROR	Warning	2.49+
71	AIR INLET TEMPERATURE SENSOR ERROR	Warning	2.49+
72	AIR OUTLET TEMPERATURE SENSOR ERROR	Warning	2.49+
73	AMBIENT TEMPERATURE SENSOR ERROR	Warning	2.49+
74	CARTER TEMPERATURE SENSOR ERROR	Warning	2.49+
75	FREON SUCTION TEMPERATURE SENSOR ERROR	Warning	2.49+
76	FREON DISCHARGE TEMPERATURE SENSOR ERROR	Warning	2.49+
77	FREON CONDENSING TEMPERATURE SENSOR ERROR	Warning	2.49+

100	UNIT CONNECTED	Message	2.49+
101	UNIT NOT CONNECTED	Message	2.49+

## 4. Document-Changes

This appendix contains all changes that have been applied to this document up to the current version:

### 1. Changes from V 1.00 to V 1.01

All descriptions regarding the 'Status-Report' have been moved to the document 'Hirolink for Modbus V X.XX - General Documentation' (X.XX is a placeholder for the current version of the Hirolink).

### 2. Changes from V 1.01 to V 1.02

The following changes were applied:

- The Hirolink-version-number was updated from V 2.74 to V 2.75.
- The Dryer V 2.50 was added to the compatibility-list.
- The description of coil 19 'Temperature' was corrected.
- The description of event-id 57 'ALARM ACKNOWLEDGE' was corrected.

### 3. Changes from V 1.03 to V 1.04

The following changes were applied:

- The Hirolink-version-number was updated from V 2.83 to V 2.84.
- An additional comment for the use of the 'Status Report Block' (Input-registers #1-#6) was added.
- A description for the input-register #7 (System Status) was added.
- The 'Unit'-description for the input-registers #17-#19 was corrected.
- The Event-list was corrected.

## Connectivity

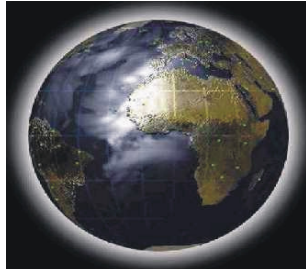

*the evolution*

## Hirolink for Modbus

(07) Items for Superchiller (GSH) (Macroface).doc

English

04/11/03 Release 1.02E

<b>1.</b>	<b>INTRODUCTION SUPERCHILLER (GSH) (MACROFACE)</b> .....	<b>2</b>
<b>2.</b>	<b>COMPATIBILITY-LIST</b> .....	<b>2</b>
<b>3.</b>	<b>ITEMS FOR SUPERCHILLER (GSH) (MACROFACE)</b> .....	<b>2</b>
3.1	COILS .....	2
3.2	INPUT-STATUS .....	2
3.3	HOLDING REGISTER .....	2
3.4	INPUT-REGISTER .....	2
3.5	EVENTS .....	2
<b>4.</b>	<b>DOCUMENT-CHANGES</b> .....	<b>2</b>

# 1. Introduction Superchiller (GSH) (Macroface)

This document contains a description of all data-points that are available via the 'Hirolink for Modbus' from this type of air-conditioner.

## **IMPORTANT:**

It is vital to the correct integration of the Hirolink into a Modbus-network, that you have read and understood the topics described in the document 'Hirolink for Modbus V X.XX - General Documentation' (X.XX is a placeholder for the current version of the Hirolink). So, if you haven't read this document until now, read it first.

## 2. Compatibility-List

Before connecting a Hiromatic to the Modbus-Hirolink you must check, if the Hiromatic-software-version is compatible with this version of the Hirolink.

You can do this by checking the labels on the eproms, which are inserted into the Hiromatic and the Macroface. The eprom inserted in the Hiromatic must be called GSH (or GSB) + Version-Number (e.g. GSH256 or GSB256) and the one inserted in the Macroface must be called MSH (or MSB) + Version-Number (e.g. MSH256 or MSB256).

To make sure that the label on the eproms is correct, you should also check the version-information, that the Hiromatic displays shortly after start-up. This information should look similar to the following illustration:

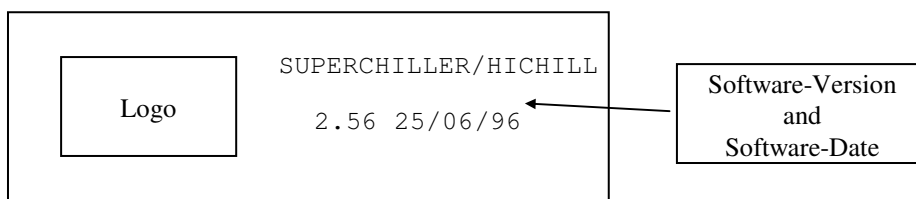

The important information in this window is only the software-version and the software-date. Make sure that the software-version installed in your installation matches one of the compatible versions listed below:

<b>Version</b>	<b>Date</b>
2.50	10/08/95
2.51	21/10/95
2.52	20/11/95
2.55	21/03/96
2.56	25/06/96
2.57	18/02/97
2.58	07/03/97

### 3. Items for Superchiller (GSH) (Macroface)

According to the Modbus-protocol-specifications the values and parameters provided by the Hiromatic are represented in 4 groups:

- Coils: Used for changeable, digital values
- Inputs: Used for not changeable, digital values
- Holding Registers: Used for changeable, analog values
- Input Registers: Used for not changeable, analog values

This Hirolink can be compatible with more than one version of this Hiromatic-type and it is possible that there have been extensions in the number of available items from one version to the next.

Therefore the column 'SW-Version' contained in the following lists provides information about the availability of each item depending on the Hiromatic-software-version. For example a entry like '2.50+' means, that this item is available from Hiromatics with software-version 2.50 and higher.

#### **IMPORTANT:**

The available data-points shown in the following chapters are numbered starting from 1, according to the Modbus-Protocol-Specification. Still some BMS start numbering the data-points from 0. So, in case that the BMS you are using starts numbering from 0, you have to decrease the listed numbers by 1.

#### **3.1 Coils**

Coil #	Usage	SW-Version
1	Set system off (Command)	2.50+
2	Set system on (Command)	2.50+
3	Not used	2.50+
4	Not used	2.50+
5	Set alarm acknowledge (Command)	2.50+
6	Set alarm reset (Command)	2.50+
7	Set standard-settings (Command)	2.50+
8	Not used	2.50+
9	System remote	2.50+
10	Single remote	2.50+
11	Not used	2.50+
12	Not used	2.50+
13	Not used	2.50+
14	Not used	2.50+
15	Not used	2.50+
16	Not used	2.50+
17	Status-Report-Acknowledge	2.50+

#### **IMPORTANT:**

Read the document 'Hirolink for Modbus V X.XX - General Documentation' (X.XX is a placeholder for the current version of the Hirolink) for a description on how to use the coils marked with 'Command'.

#### **Status-Report-Acknowledge (Coil #17):**

Read the document 'Hirolink for Modbus V X.XX - General Documentation' (X.XX is a placeholder for the current version of the Hirolink) for a description on how to use this data-point.



### 3.2 Input-Status

Input-Status #	Usage	SW-Version
1	System on	2.50+
2	Manual on	2.50+
3	Not used	2.50+
4	System remote enabled	2.50+
5	Remote on	2.50+
6	Freecooling on	2.50+
7	Pumpdown after system off	2.50+
8	Antifreeze operation	2.50+
9	Alarm active	2.50+
10	Warning active	2.50+
11	Not used	2.50+
12	Alarm acknowledged	2.50+
13	Not used	2.50+
14	Not used	2.50+
15	Not used	2.50+
16	Not used	2.50+
17	System on (MF 1)	2.50+
18	Manual on (MF 1)	2.50+
19	Stand by (MF 1)	2.50+
20	Single remote enabled (MF 1)	2.50+
21	Remote on (MF 1)	2.50+
22	Freecooling on (MF 1)	2.50+
23	Alarm system off (MF 1)	2.50+
24	Alarm off (MF 1)	2.50+

The items 17-24 are repeated for each Macroface on the Superchiller-System:

- Items 25-32: MF 2
- Items 33-40: MF 3
- Items 41-48: MF 4
- Items 49-56: MF 5
- Items 57-64: MF 6
- Items 65-72: MF 7
- Items 73-80: MF 8

Input-Status #	Usage	SW-Version
81	Alarm active (MF 1)	2.50+
82	Warning active (MF 1)	2.50+
83	Stand alone (MF 1)	2.50+
84	Defect (MF 1)	2.50+
85	Pump 1 active (MF 1)	2.50+
86	Semi- (0), Fullhermetic (1) (MF 1)	2.50+
87	Pump 2 active (MF 1)	2.50+
88	Maintenance (MF 1)	2.50+

The items 81-88 are repeated for each Macroface on the Superchiller-System:

- Items 89-96: MF 2
- Items 97-104: MF 3
- Items 105-112: MF 4
- Items 113-120: MF 5
- Items 121-128: MF 6
- Items 129-136: MF 7
- Items 137-144: MF 8

Input-Status #	Usage	SW-Version
145	Pumpdown after system off (MF 1)	2.50+
146	Antifreeze operation (MF 1)	2.50+
147	Not used (MF 1)	2.50+
148	Not used (MF 1)	2.50+
149	Not used (MF 1)	2.50+
150	Not used (MF 1)	2.50+
151	Not used (MF 1)	2.50+
152	Not used (MF 1)	2.50+

The items 145-152 are repeated for each Macroface on the Superchiller-System:

Items 153-160: MF 2  
Items 161-168: MF 3  
Items 169-176: MF 4  
Items 177-184: MF 5  
Items 185-192: MF 6  
Items 193-200: MF 7  
Items 201-208: MF 8

### 3.3 Holding Register

Register #	Usage	Range; Unit	SW-Version
1	Status-Report-Acknowledge	See description below	2.50+
2	Auto-restart time	0->No auto-restart, 5-60 s; [5s]	2.50+
3	Operating mode	0 -> A, 1 -> B, 2 -> C	2.50+
4	Pump time	0 - 15 min. (only valid in Operating mode B)	2.50+
5	Stand by unit 1	0 -> No, 1 - 8	2.50+
6	Stand by unit 2	0 -> No, 1 - 8	2.50+
7	Stand by rotation	0..No, 1..Daily, 2..Weekly	2.50+
8	Mixture inlet temperature at 100%	-5.0 - 25.0 °C; [1/10 °C]	2.50+
9	Mixture inlet temperature at 0%	-5.0 - 25.0 °C; [1/10 °C]	2.50+
10	Second setpoint	-5.0 - 25.0 °C; [1/10 °C]	2.50+
11	Proportional band	1.0 - 10.0 °C; [1/10 °C]	2.50+
12	Integration factor	0->No integration, 5 - 20 min.; [min.]	2.50+
13	Min. mixture outlet temperature	49 -> No, 5.0 - 25.0 °C; [1/10 °C]	2.50+
14	Max. mixture outlet temperature	49 -> No, 5.0 - 25.0 °C; [1/10 °C]	2.50+
15	Condenser step 1	4 -> No, 5 - 25 bar; [bar]	2.50+
16	Condenser step 2	4 -> No, 5 - 25 bar; [bar]	2.50+
17	Condenser hysteresis	1 - 10 bar; [bar]	2.50+
18	Antifreeze operation at	-101 -> No, -10.0 - 10.0 °C; [1/10 °C]	2.50+
19	High mixture inlet warning level	-151 -> No, -15.0 - 25.0 °C; [1/10 °C]	2.50+
20	Low mixture inlet warning level	-151 -> No, -15.0 - 25.0 °C; [1/10 °C]	2.50+
21	High mixture outlet warning level	-151 -> No, -15.0 - 25.0 °C; [1/10 °C]	2.50+
22	Low mixture outlet warning level	-151 -> No, -15.0 - 25.0 °C; [1/10 °C]	2.50+
23	High mixture inlet alarm level	-151 -> No, -15.0 - 25.0 °C; [1/10 °C]	2.50+
24	Low mixture inlet alarm level	-151 -> No, -15.0 - 25.0 °C; [1/10 °C]	2.50+
25	High mixture outlet alarm level	-151 -> No, -15.0 - 25.0 °C; [1/10 °C]	2.50+
26	Low mixture outlet alarm level	-151 -> No, -15.0 - 25.0 °C; [1/10 °C]	2.50+
27	High pressure warning at	5.0 - 25.0 bar; [1/10 bar]	2.50+
28	Minimum mixture pressure at	0.0 - 10.0 bar; [1/10 bar]; MSB: 0..Warning, 1..Alarm	2.50+
29	Low pressure alarm delay	0 - 360 s; [5s]	2.50+
30	Freeze alarm	-25 - 10 °C; [°C]	2.50+

#### Status-Report-Acknowledge (Holding Register #1):

Read the document 'Hirolink for Modbus V X.XX - General Documentation' (X.XX is a placeholder for the current version of the Hirolink) for a description on how to use this data-point.

### 3.4 Input-Register

Register #	Usage	Unit	SW-Version
1	Event-ID	ID identifying the event	2.50+
2	Controller-ID	Controller-ID, where the event occurred	2.50+
3	Minute	Minute, when event occurred	2.50+
4	Hour	Hour, when event occurred	2.50+
5	Date	Date, when event occurred	2.50+
6	Event-Type	0 -> message, 1 -> warning, 2 -> alarm, 3 -> reset	2.50+
7	System status	See explanation below	2.50+
8	MF status 1	See explanation below	2.50+
9	MF status 2	See explanation below	2.50+
10	MF status 3	See explanation below	2.50+
11	MF status 4	See explanation below	2.50+
12	MF status 5	See explanation below	2.50+
13	MF status 6	See explanation below	2.50+
14	MF status 7	See explanation below	2.50+
15	MF status 8	See explanation below	2.50+
16	System inlet temperature	[1/10 °C]	2.50+
17	System outlet temperature	[1/10 °C]	2.50+
18	System ambient temperature	[1/10 °C]	2.50+
19	System setpoint	[1/10 °C]	2.50+
20	System FC	[%]	2.50+
21	System DE	[%]	2.50+
22	System mixture pressure	[1/10 bar]	2.50+
23	System setpoint shifting	[%]	2.50+
24	Current system setpoint	[1/10 °C]	2.50+
25	System user 1 input	Depends on configuration	2.50+
26	System user 2 input	Depends on configuration	2.50+
27	Number of slaves		2.50+
28-35	Inlet temperature (MF 1-8)	[1/10 °C]	2.50+
36-43	Outlet temperature (MF 1-8)	[1/10 °C]	2.50+
44-51	Ambient temperature (MF 1-8)	[1/10 °C]	2.50+
52-59	Setpoint Shifting (MF 1-8)	128 -> No; [%]	2.50+
60-67	Relative compressor-capacity (MF 1-8)		2.50+
68-75	Relative freecooling-capacity (MF 1-8)		2.50+
76-83	DE (MF 1-8)	[%]	2.50+
84-91	FC (MF 1-8)	[%]	2.50+
92-99	High pressure sensor 1 (MF 1-8)	[1/10 bar]	2.50+
100-107	High pressure sensor 2 (MF 1-8)	[1/10 bar]	2.50+
108-115	High pressure sensor 3 (MF 1-8)	[1/10 bar]	2.50+
116-123	High pressure sensor 4 (MF 1-8)	[1/10 bar]	2.50+
124-131	Mixture Pressure (MF 1-8)	[1/10 bar]	2.50+
132-139	User input 1 (MF 1-8)	Depends on configuration	2.50+
140-147	User input 2 (MF 1-8)	Depends on configuration	2.50+

## Status-Report-Block (Input Register #1 - #6):

Read the document 'Hirolink for Modbus V X.XX - General Documentation' (X.XX is a placeholder for the current version of the Hirolink) for a description on how to use these data-points.

## System-Status and MF-Status (Input Register #7 - #15):

These items hold a value, which represents the current state of the whole system (System-Status) or the single Macrofaces (MF-Status) respectively.

### **NOTE:**

Bit #7 doesn't contain valid information and should be masked out, i.e. you either set bit #7 to 0 before checking the value or you subtract 128, when the value is higher equal or higher than that.

The values correspond to the following states:

- 1..System Off
- 2..System On
- 3..System On P1
- 4..System On P2
- 5..Remote Off
- 6..Remote Off / Stand By
- 7..Remote On
- 8..Remote On P1
- 9..Remote On P2
- 10..Manual On
- 11..Manual On P1
- 12..Manual On P2
- 13..Maint
- 14..Maint / Stand By
- 15..Alarm Off
- 16..Alarm On
- 17..Alarm On P1
- 18..Alarm On P2
- 19..Warning Off
- 20..Warning On
- 21..Warning On P1
- 22..Warning On P2
- 23..Stand By Off
- 24..Stand By On
- 25..Stand By On P1
- 26..Stand By On P2
- 27..Stand Alone Off
- 28..Stand Alone On
- 29..Stand Alone On P1
- 30..Stand Alone On P2
- 31..Defect
- 32..Antifreeze On
- 33..Antifreeze On P1
- 34..Antifreeze On P2

### 3.5 Events

#### **IMPORTANT:**

Read the document 'Hirolink for Modbus V X.XX - General Documentation' (X.XX is a placeholder for the current version of the Hirolink) for a detailed description on how to use these data-points.

In the following list you can see all Events and Event-IDs available for Superchiller/Hichill units:

Event-ID	Event-Description	Event-Type	SW-Version
1	HIGH PRESSURE COMPRESSOR 1, check freon circuit + condenser	Alarm	2.50+
2	HIGH PRESSURE COMPRESSOR 2, check freon circuit + condenser	Alarm	2.50+
3	HIGH PRESSURE COMPRESSOR 3, check freon circuit + condenser	Alarm	2.50+
4	HIGH PRESSURE COMPRESSOR 4, check freon circuit + condenser	Alarm	2.50+
5	LOW PRESSURE COMPRESSOR 1, check freon circuit	Alarm	2.50+
6	LOW PRESSURE COMPRESSOR 2, check freon circuit	Alarm	2.50+
7	LOW PRESSURE COMPRESSOR 3, check freon circuit	Alarm	2.50+
8	LOW PRESSURE COMPRESSOR 4, check freon circuit	Alarm	2.50+
9	OIL DIFF. PRESSURE COMPRESSOR 1	Alarm	2.50+
10	OIL DIFF. PRESSURE COMPRESSOR 2	Alarm	2.50+
11	MOTOR PROTECTION COMPRESSOR 1	Alarm	2.50+
12	MOTOR PROTECTION COMPRESSOR 2	Alarm	2.50+
13	FREEZE ALARM	Alarm	2.50+
14	FANS MOTOR PROTECTION 1	Warning	2.50+
15	FANS MOTOR PROTECTION 2	Warning	2.50+
16	FANS MOTOR PROTECTION 3	Warning	2.50+
17	FANS MOTOR PROTECTION 4	Warning	2.50+
18	USER INPUT #1 TRIGGERED	Alarm	2.50+
19	USER INPUT #2 TRIGGERED	Alarm	2.50+
20	MIXTURE FLOW SWITCH	Alarm	2.50+
21	HIGH PRESSURE WARNING COMPRESSOR 1 STOPPED	Message	2.50+
22	HIGH PRESSURE WARNING COMPRESSOR 2 STOPPED	Message	2.50+
23	HIGH PRESSURE WARNING COMPRESSOR 3 STOPPED	Message	2.50+
24	HIGH PRESSURE WARNING COMPRESSOR 4 STOPPED	Message	2.50+
25	MINIMUM MIXTURE PRESSURE	Alarm	2.50+
26	HIGH MIXTURE INLET TEMPERATURE	Warning	2.50+
27	LOW MIXTURE INLET TEMPERATURE	Warning	2.50+
28	HIGH MIXTURE OUTLET TEMPERATURE	Warning	2.50+
29	LOW MIXTURE OUTLET TEMPERATURE	Warning	2.50+
30	HIGH MIXTURE INLET TEMPERATURE	Alarm	2.50+
31	LOW MIXTURE INLET TEMPERATURE	Alarm	2.50+
32	HIGH MIXTURE OUTLET TEMPERATURE	Alarm	2.50+
33	LOW MIXTURE OUTLET TEMPERATURE	Alarm	2.50+
34	MINIMUM MIXTURE PRESSURE	Warning	2.50+
35	USER INPUT #1 TRIGGERED	Warning	2.50+
36	USER INPUT #2 TRIGGERED	Warning	2.50+
37	MIXTURE FLOW SWITCH	Warning	2.50+
38	MIXTURE FLOW SWITCH	Warning	2.50+
39	EEPROM ERROR SYSTEM-CONFIGURATION	Alarm	2.50+
40	SYSTEM WORKING HOURS THRESHOLD EXCEEDED	Warning	2.50+

41	MIXTURE PUMP 1 WORKING HOURS THRESHOLD EXCEEDED	Warning	2.50+
42	MIXTURE PUMP 2 WORKING HOURS THRESHOLD EXCEEDED	Warning	2.50+
43	COMPRESSOR 1 WORKING HOURS THRESHOLD EXCEEDED	Warning	2.50+
44	COMPRESSOR 2 WORKING HOURS THRESHOLD EXCEEDED	Warning	2.50+
45	COMPRESSOR 3 WORKING HOURS THRESHOLD EXCEEDED	Warning	2.50+
46	COMPRESSOR 4 WORKING HOURS THRESHOLD EXCEEDED	Warning	2.50+
47	HIGH PRESSURE WARNING COMPRESSOR 1	Message	2.50+
48	HIGH PRESSURE WARNING COMPRESSOR 2	Message	2.50+
49	ADDRESS ERROR: 2 SB WITH SAME ADDRESS	Message	2.50+
50	POWER RESTORED	Reset	2.50+
51	POWER OFF	Message	2.50+
52	SYSTEM ON	Message	2.50+
53	SYSTEM OFF	Message	2.50+
54	REMOTE ON	Message	2.50+
55	REMOTE OFF	Message	2.50+
56	ALARM RESET	Reset	2.50+
57	ALARM ACKNOWLEDGED	Message	2.50+
58	MANUAL MODE	Message	2.50+
59	COMPRESSOR PUMPDOWN	Message	2.50+
60	RAM ERROR, replace display board	Message	2.50+
61	EPROM ERROR, please replace eprom	Alarm	2.50+
62	EEPROM ERROR, replace display board	Alarm	2.50+
63	CONTROLLERBOARD FAILURE please replace	Alarm	2.50+
64	INTERFACE BOARD ERROR please replace	Alarm	2.50+
65	AMBIENT SENSOR FAILURE please replace sensor	Warning	2.50+
66	MIXTURE INLET SENSOR FAILURE, replace sensor	Alarm	2.50+
67	MIXTURE OUTLET MASTER SENSOR FAILURE	Warning	2.50+
68	DISPLAY BOARD FAILURE X please replace	Message	2.50+
69	EVAPORATOR MIXTURE INLET SINGLE SENSOR FAILURE	Alarm	2.50+
70	MIXTURE OUTLET SINGLE SENSOR FAILURE	Warning	2.50+
71	MIXTURE INLET SENSOR FAILURE, replace sensor	Alarm	2.50+
72	EVAPORATOR MIXTURE INLET SINGLE SENSOR FAILURE	Warning	2.50+
73	ANTIFREEZE OPERATION	Message	2.50+
74	LOCAL ON/OFF DISABLED	Message	2.50+
75	COMPRESSORS DISABLED	Message	2.50+
76	COMPRESSORS ENABLED	Message	2.50+
77	FREECOOLING DISABLED	Message	2.50+
78	FREECOOLING ENABLED	Message	2.50+

100	UNIT CONNECTED	Message	2.50+
101	UNIT NOT CONNECTED	Message	2.50+

## 4. Document-Changes

This appendix contains all changes that have been applied to this document up to the current version:

### 1. Changes from V 1.00 to V 1.01

The chapter describing 'Networking Systems' has been removed, because it is now available in the document 'Hirolink for Modbus V X.XX - General Documentation' (X.XX is a placeholder for the current version of the Hirolink).

Also all descriptions regarding the 'Status-Report' have been moved to this document.

### 2. Changes from V 1.01 to V 1.02

The description of the items 'System-Status' and 'MF-Status' was corrected.

## Connectivity



*the evolution*

## Hirolink for Modbus

**(08) Items for GS Chiller (GGS) (Macroface).doc**

**English**

04/11/03 Release 1.01E

<b>1.</b>	<b>INTRODUCTION GS CHILLER (GGS) (MACROFACE)</b> .....	<b>3</b>
<b>2.</b>	<b>COMPATIBILITY-LIST</b> .....	<b>3</b>
<b>3.</b>	<b>ITEMS FOR GS CHILLER (GGS) (MACROFACE)</b> .....	<b>3</b>
3.1	COILS.....	4
3.2	INPUT-STATUS .....	4
3.3	HOLDING REGISTER.....	7
3.4	INPUT-REGISTER .....	9
3.5	EVENTS.....	11
<b>4.</b>	<b>DOCUMENT-CHANGES</b> .....	<b>12</b>



## 1. Introduction GS Chiller (GGS) (Macroface)

This document contains a description of all data-points that are available via the 'Hirolink for Modbus' from this type of air-conditioner.

### **IMPORTANT:**

It is vital to the correct integration of the Hirolink into a Modbus-network, that you have read and understood the topics described in the document 'Hirolink for Modbus V X.XX - General Documentation' (X.XX is a placeholder for the current version of the Hirolink). So, if you haven't read this document until now, read it first.

## 2. Compatibility-List

Before connecting a Hiromatic to the Modbus-Hirolink you must check, if the Hiromatic-software-version is compatible with this version of the Hirolink.

You can do this by checking the labels on the eproms, which are inserted into the Hiromatic and the Macroface. The eprom inserted in the Hiromatic must be called GGS + Version-Number (e.g. GGS249) and the one inserted in the Macroface must be called MGS + Version-Number (e.g. MGS249).

To make sure that the label on the eproms is correct, you should also check the version-information, that the Hiromatic displays shortly after start-up. This information should look similar to the following illustration:

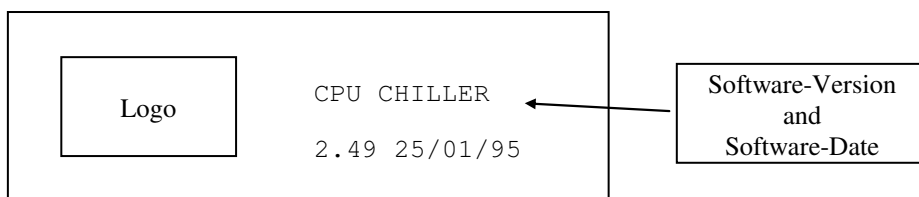

The important information in this window is only the software-version and the software-date. Make sure that the software-version installed in your installation matches one of the compatible versions listed below:

<b>Version</b>	<b>Date</b>
2.49	25/01/95
2.49B1	17/03/95
2.49B2	09/08/95

## 3. Items for GS Chiller (GGS) (Macroface)

According to the Modbus-protocol-specifications the values and parameters provided by the Hiromatic are represented in 4 groups:

- Coils: Used for changeable, digital values
- Inputs: Used for not changeable, digital values
- Holding Registers: Used for changeable, analog values
- Input Registers: Used for not changeable, analog values

This Hirolink can be compatible with more than one version of this Hiromatic-type and it is possible that there have been extensions in the number of available items from one version to the next. Therefore the column 'SW-Version' contained in the following lists provides information about the availability of each item depending on the Hiromatic-software-version. For example a entry like '2.49+' means, that this item is available from Hiromatics with software-version 2.49 and higher.

**IMPORTANT:**

The available data-points shown in the following chapters are numbered starting from 1, according to the Modbus-Protocol-Specification. Still some BMS start numbering the data-points from 0. So, in case that the BMS you are using starts numbering from 0, you have to decrease the listed numbers by 1.

**3.1 Coils**

Coil #	Usage	SW-Version
1	Set system off (Command)	2.49+
2	Set system on (Command)	2.49+
3	Not used	2.49+
4	Not used	2.49+
5	Set alarm acknowledge (Command)	2.49+
6	Set alarm reset (Command)	2.49+
7	Set standard settings (Command)	2.49+
8	Not used	2.49+
9	Set system off MF 1 (Command)	2.49+
10	Set system on MF 1 (Command)	2.49+
11	Not used	2.49+
12	Not used	2.49+
13	Not used	2.49+
14	Not used	2.49+
15	Not used	2.49+
16	Not used	2.49+

The items 9-16 are repeated for each MF on the GS-System:

- Items 17-24: MF 2
- Items 25-32: MF 3
- Items 33-40: MF 4
- Items 41-48: MF 5
- Items 49-56: MF 6
- Items 57-64: MF 7
- Items 65-72: MF 8

73	Status-Report-Acknowledge	2.49+
----	---------------------------	-------

**IMPORTANT:**

Read the document 'Hirolink for Modbus V X.XX - General Documentation' (X.XX is a placeholder for the current version of the Hirolink) for a description on how to use the coils marked with 'Command'.

**Status-Report-Acknowledge (Coil #73):**

Read the document 'Hirolink for Modbus V X.XX - General Documentation' (X.XX is a placeholder for the current version of the Hirolink) for a description on how to use this data-point.

**3.2 Input-Status**

Input-Status #	Usage	SW-Version
1	Remote On/Off MF 1	2.49+
2	Compressor high pressure MF 1	2.49+
3	Compressor low pressure MF 1	2.49+
4	Compressor motor protection MF 1	2.49+
5	Freeze protection MF 1	2.49+
6	Rad cooler 1 alarm MF 1	2.49+
7	Rad cooler 2 alarm MF 1	2.49+

8	User input 1 MF 1	2.49+
---	-------------------	-------

The items 1-8 are repeated for each MF on the GS-System:

Items 9-16: MF 2  
 Items 17-24: MF 3  
 Items 25-32: MF 4  
 Items 33-40: MF 5  
 Items 41-48: MF 6  
 Items 49-56: MF 7  
 Items 57-64: MF 8

Input Status #	Usage	SW-Version
65	Stop compressor MF 1	2.49+
66	Start compressor MF 1	2.49+
67	Stop freecooling MF 1	2.49+
68	Start freecooling MF 1	2.49+
69	Stop unit MF 1	2.49+
70	Second setpoint MF 1	2.49+
71	Glycol flow switch MF 1	2.49+
72	Water flow switch MF 1	2.49+

The items 65-72 are repeated for each MF on the GS-System:

Items 73-80: MF 2  
 Items 81-88: MF 3  
 Items 89-96: MF 4  
 Items 97-104: MF 5  
 Items 105-112: MF 6  
 Items 113-120: MF 7  
 Items 121-128: MF 8

Input-Status #	Usage	SW-Version
129	Glycol pump 1 MF 1	2.49+
130	Glycol pump 2 MF 1	2.49+
131	Water pump 1 MF 1	2.49+
132	Water pump 2 MF 1	2.49+
133	Radcooler step 1 MF 1	2.49+
134	Radcooler step 2 MF 1	2.49+
135	Freecooling command DIR MF 1	2.49+
136	Freecooling command REV MF 1	2.49+

The items 129-136 are repeated for each MF on the GS-System:

Items 137-144: MF 2  
Items 145-152: MF 3  
Items 153-160: MF 4  
Items 161-168: MF 5  
Items 169-176: MF 6  
Items 177-184: MF 7  
Items 185-192: MF 8

Input-Status #	Usage	SW-Version
193	Glycol pumps warning MF 1	2.49+
194	Glycol pumps alarm MF 1	2.49+
195	Water pumps warning MF 1	2.49+
196	Water pumps alarm MF 1	2.49+
197	Compressor ON MF 1	2.49+
198	Temperature WA/AL MF 1	2.49+
199	Compressor AL MF 1	2.49+
200	Warning MF 1	2.49+

The items 193-200 are repeated for each MF on the GS-System:

Items 201-208: MF 2  
Items 209-216: MF 3  
Items 217-224: MF 4  
Items 225-232: MF 5  
Items 233-240: MF 6  
Items 241-248: MF 7  
Items 249-256: MF 8

### 3.3 Holding Register

Register #	Usage	Range; Unit	SW-Version
1	Status-Report-Acknowledge	See description below	2.49+
2	Language	0 -> English, 1 -> German, 2 -> Spanish	2.49+
3	Temperature °C/°F	0 -> °F, 1 -> °C	2.49+
4	Auto restart time	0 -> No, 1 - 10; [min]	2.49+
5	Remote	See description below	2.49+
6	Function of room-sensor	See description below	2.49+
7	Stand by unit 1	0 -> No, 1 .. 8	2.49+
8	Stand by unit 2	0 -> No, 1 .. 8	2.49+
9	Rotation	See description below	2.49+
10	Start unit 1	9 -> No, 10 - 100; [1/10 K]	2.49+
11	Start unit 2	9 -> No, 10 - 100; [1/10 K]	2.49+
12	Hysteresis	9 -> No, 10 - 100; [1/10 K]	2.49+
13-20	Designed difference inlet - outlet temp. (MF 1-8)	1 - 100; [1/10 K]	2.49+
21-28	Basic setpoint (MF 1-8)	0 - 50; [1/10 °C]	2.49+
29-36	Valve deadband (MF 1-8)	0 - 50; [1/10 V]	2.49+
37-44	Second setpoint (MF 1-8)	0 - 500; [1/10 °C]	2.49+
45-52	Proportional band (MF 1-8)	0 - 200; [1/10 °C]	2.49+
53-60	Integration factor (MF 1-8)	0 - 50; [min]	2.49+
61-68	Shifting kind (MF 1-8)	See description below	2.49+
69-76	Basic outlet setpoint at (Roomtemp. shifting) (MF 1-8)	0 - 500; [1/10 °C]	2.49+
77-84	Highest outlet setpoint at (Roomtemp. shifting) (MF 1-8)	0 - 500; [1/10 °C]	2.49+
85-92	Outlet setpoint shifting range (Roomtemp. shifting) (MF 1-8)	1 - 100; [1/10 K]	2.49+
92-100	Shifting speed (Roomtemp. shifting) (MF 1-8)	1 - 10; [K/min]	2.49+
101-108	Outlet setpoint shifting range (Voltage shifting) (MF 1-8)	-1.0 - 100; [1/10 K]	2.49+
109-116	Shifting speed (Voltage shifting) (MF 1-8)	1 - 10; [K/min]	2.49+
117-124	Diff. outdoor - water out (MF 1-8)	0 - 100; [1/10 K]	2.49+
125-132	Diff. RC in - water out (MF 1-8)	0 - 100; [1/10 K]	2.49+
133-140	Compressor stop at low load (MF 1-8)	9->No, 10 - 50; [%]	2.49+
141-148	Glycol temp. for step 1 FC (MF 1-8)	0 - 50; [°C]	2.49+
149-156	Glycol temp. for step 1 DX (MF 1-8)	0 - 50; [°C]	2.49+
157-164	Glycol temp. for step 2 FC (MF 1-8)	0 - 50; [°C]	2.49+
165-172	Glycol temp. for step 2 DX (MF 1-8)	0 - 50; [°C]	2.49+
173-180	Integration factor for both RC outputs (MF 1-8)	0 -> No, 1 - 50; [min]	2.49+
181-188	Proportional band for both RC outputs (MF 1-8)	0 - 100; [1/10 °C]	2.49+
189-196	Compressor stop at capacity (MF 1-8)	0 - 100; [%]	2.49+
197-204	Compressor start at capacity (MF 1-8)	0 - 100; [%]	2.49+
205-212	Valve offset (MF 1-8)	0 - 100; [%]	2.49+
213-220	Temp. Hum. alarm delay (MF 1-8)	0 -> No, 1 - 10; [min]	2.49+
221-228	High water inlet warning (MF 1-8)	0 -> No, 0 - 10; [K]	2.49+
229-236	High water inlet alarm (MF 1-8)	0 -> No, 0 - 20; [K]	2.49+
237-244	Low water outlet warning (MF 1-8)	0 -> No, 0 - (-10); [K]	2.49+
245-252	Low water outlet alarm (MF 1-8)	0 -> No, 0 - (-10); [K]	2.49+
253-260	High room temp. warning (MF 1-8)	0 - 50; [°C]	2.49+
261-268	High room temp. alarm (MF 1-8)	0 - 50; [°C]	2.49+
269-276	Freecooling backup (MF 1-8)	0 -> No, 1 -> Yes	2.49+
277-284	Compressor capacity at sensor-failure (MF 1-8)	10 - 100; [%]	2.49+

### Status-Report-Acknowledge (Holding Register #1):

Read the document 'Hirolink for Modbus V X.XX - General Documentation' (X.XX is a placeholder for the current version of the Hirolink) for a description on how to use this data-point.

### Remote (Holding Register #5):

- 0 .. No
- 1 .. System
- 2 .. Single
- 3 .. Lock System
- 4 .. Lock Single

### Function of room-sensor (Holding Register #6):

- 0 .. No
- 1 .. System
- 2 .. Single
- 3 .. AV - Max

### Rotation (Holding Register #9):

- 0 .. No
- 1 .. Daily
- 2 .. Weekly

### Shifting kind (Holding Register #61-#68):

- 0 .. No shifting
- 1 .. Humidity shifting
- 2 .. Room-temperature shifting
- 3 .. Humidity and room-temperature shifting
- 4 .. Voltage shifting
- 5 .. Humidity and voltage shifting
- 6 .. Room-temperature and voltage shifting
- 7 .. Humidity, room-temperature and voltage shifting

### 3.4 Input-Register

Register #	Usage	Unit	SW-Version
1	Event-ID	ID identifying the event	2.49+
2	Controller-ID	Controller-ID, where the event occurred	2.49+
3	Minute	Minute, when event occurred	2.49+
4	Hour	Hour, when event occurred	2.49+
5	Date	Date, when event occurred	2.49+
6	Event-Type	0 -> message, 1 -> warning, 2 -> alarm, 3 -> reset	2.49+
7	System status	See description below	2.49+
8	MF status 1	See description below	2.49+
9	MF status 2	See description below	2.49+
10	MF status 3	See description below	2.49+
11	MF status 4	See description below	2.49+
12	MF status 5	See description below	2.49+
13	MF status 6	See description below	2.49+
14	MF status 7	See description below	2.49+
15	MF status 8	See description below	2.49+
16	System water inlet temperature	[1/10 °C]	2.49+
17	System water outlet temperature	[1/10 °C]	2.49+
18	System room temperature	[1/10 °C]	2.49+
19	System Load	[%]	2.49+
20	System Used capacity	[%]	2.49+
21-28	Water inlet temperature (MF 1-8)	[1/10 °C]	2.49+
29-36	Water outlet temperature (MF 1-8)	[1/10 °C]	2.49+
37-44	Outdoor temperature (MF 1-8)	[1/10 °C]	2.49+
45-52	System Outdoor temperature (MF 1-8)	[1/10 °C]	2.49+
53-60	Room temperature (MF 1-8)	[1/10 °C]	2.49+
61-68	Actual setpoint (MF 1-8)	[1/10 °C]	2.49+
69-76	Setpoint shifting (MF 1-8)	[1/10 °C]	2.49+
77-84	FC-valve (MF 1-8)	[%]	2.49+
85-92	HG-valve (MF 1-8)	[%]	2.49+
93-100	Load (MF 1-8)	[%]	2.49+
101-108	High pressure sensor (MF 1-8)	[1/10 bar]	2.49+
109-116	Water pressure sensor (MF 1-8)	[1/10 bar]	2.49+
117-124	Glycol temperature sensor (MF 1-8)	[1/10 °C]	2.49+
125-132	Glycol pressure sensor (MF 1-8)	[1/10 bar]	2.49+
133-140	Hot gas bypass valve (MF 1-8)	[%]	2.49+
141-148	Freecooling valve (MF 1-8)	[%]	2.49+
149-156	Radcooler fanspeed 1 (MF 1-8)	[%]	2.49+
157-164	Radcooler fanspeed 2 (MF 1-8)	[%]	2.49+

## Status-Report-Block (Input Register #1 - #6):

Read the document 'Hirolink for Modbus V X.XX - General Documentation' (X.XX is a placeholder for the current version of the Hirolink) for a description on how to use these data-points.

## System-Status and MF-Status (Input Register #7 - #15):

These items hold a value, which represents the current state of the whole system (System-Status) or the single Macrofaces (MF-Status) respectively.

The values correspond to the following states:

- 1..System off
- 2..System on
- 5..Remote off
- 6..Remote on
- 9..Manual
- 12..Maintenance
- 13..Alarm off
- 14..Alarm on
- 17..Warning off
- 18..Warning on
- 21..Stand-By off
- 22..Stand-By on
- 25..Stand Alone off
- 26..Stand Alone on
- 32..Defect



### 3.5 Events

#### **IMPORTANT:**

Read the document 'Hirolink for Modbus V X.XX - General Documentation' (X.XX is a placeholder for the current version of the Hirolink) for a detailed description on how to use these data-points.

In the following list you can see all Events and Event-IDs available for GS-units:

Event-ID	Event-Description	Event-Type	SW-Version
1	COMPRESSOR HIGH PRESSURE, check freon circuit + condenser	Alarm	2.49+
2	COMPRESSOR LOW PRESSURE, check freon circuit + condenser	Alarm	2.49+
3	MOTOR PROTECTION COMPRESSOR	Alarm	2.49+
4	FREEZE ALARM	Alarm	2.49+
5	RAD COOLER 1 MOTOR PROTECTION	Warning	2.49+
6	RAD COOLER 2MOTOR PROTECTION	Warning	2.49+
7	USER INPUT #1 TRIGGERED	Warning	2.49+
8	GLYCOL FLOW SWITCH	Alarm	2.49+
9	GLYCOL FLOW SWITCH PUMP 1	Warning	2.49+
10	GLYCOL FLOW SWITCH PUMP 2	Warning	2.49+
11	WATER FLOW SWITCH	Alarm	2.49+
12	WATER FLOW SWITCH PUMP 1	Warning	2.49+
13	WATER FLOW SWITCH PUMP 2	Warning	2.49+
14	COMPRESSOR HIGH PRESSURE, check freon circuit + condenser	Warning	2.49+
15	MINIMUM WATER PRESSURE	Alarm	2.49+
16	MINIMUM GLYCOL PRESSURE	Alarm	2.49+
17	MINIMUM WATER PRESSURE	Warning	2.49+
18	MINIMUM GLYCOL PRESSURE	Warning	2.49+
19	HIGH WATER OUTLET TEMPERATURE	Alarm	2.49+
20	HIGH WATER OUTLET TEMPERATURE	Warning	2.49+
21	LOW WATER INLET TEMPERATURE	Alarm	2.49+
22	LOW WATER INLET TEMPERATURE	Warning	2.49+
23	HIGH ROOM TEMPERATURE	Alarm	2.49+
24	HIGH ROOM TEMPERATURE	Warning	2.49+
25	HIGH ROOM HUMIDITY	Alarm	2.49+
26	HIGH ROOM HUMIDITY	Warning	2.49+
27	WATER PUMP 1 WORKING HOURS THRESHOLD EXCEEDED	Warning	2.49+
28	WATER PUMP 2 WORKING HOURS THRESHOLD EXCEEDED	Warning	2.49+
29	GLYCOL PUMP 1 WORKING HOURS THRESHOLD EXCEEDED	Warning	2.49+
30	GLYCOL PUMP 2 WORKING HOURS THRESHOLD EXCEEDED	Warning	2.49+
31	COMPRESSOR WORKING HOURS THRESHOLD EXCEEDED	Warning	2.49+
32	WATER INLET SENSOR FAILURE	Alarm	2.49+
33	WATER OUTLET SENSOR FAILURE	Warning	2.49+
34	OUTDOOR SENSOR FAILURE	Warning	2.49+
35	ROOMTEMPERATURE SENSOR FAILURE	Warning	2.49+
36	LOW GLYCOL PRESSURE	Warning	2.49+
37	LOW WATER PRESSURE	Warning	2.49+
38	WATER LEAKAGE	Warning	2.49+

39	COMPRESSOR HIGH PRESSURE, check freon circuit + condenser	Warning	2.49+
40	COMMUNICATION-FAILURE WITH UNIT 1	Alarm	2.49+
41	COMMUNICATION-FAILURE WITH UNIT 2	Alarm	2.49+
42	COMMUNICATION-FAILURE WITH UNIT 3	Alarm	2.49+
43	COMMUNICATION-FAILURE WITH UNIT 4	Alarm	2.49+
44	COMMUNICATION-FAILURE WITH UNIT 5	Alarm	2.49+
45	COMMUNICATION-FAILURE WITH UNIT 6	Alarm	2.49+
46	COMMUNICATION-FAILURE WITH UNIT 7	Alarm	2.49+
47	COMMUNICATION-FAILURE WITH UNIT 8	Alarm	2.49+
48	NOT USED		2.49+
49	ADDRESS ERROR: 2 Units with same address	Message	2.49+
50	POWER RESTORED	Reset	2.49+
51	POWER OFF	Message	2.49+
52	SYSTEM ON	Message	2.49+
53	SYSTEM OFF	Message	2.49+
54	REMOTE ON	Message	2.49+
55	REMOTE OFF	Message	2.49+
56	ALARM RESET	Reset	2.49+
57	ALARM ACKNOWLEDGED	Message	2.49+
58	MANUAL MODE	Message	2.49+
59	NOT USED		2.49+
60	RAM ERROR replace display board	Alarm	2.49+
61	EPROM ERROR please replace eprom	Alarm	2.49+
62	EEPROM ERROR	Alarm	2.49+
63	CONTROLLERBOARD FAILURE please replace	Alarm	2.49+
64	INTERFACE BOARD ERROR please replace	Alarm	2.49+
65	LOCAL ON/OFF DISABLED	Message	2.49+
66	NOT USED		2.49+
67	NOT USED		2.49+
68	DISPLAY BOARD FAILURE X please replace	Message	2.49+
100	UNIT CONNECTED	Message	2.49+
101	UNIT NOT CONNECTED	Message	2.49+

## 4. Document-Changes

This appendix contains all changes that have been applied to this document up to the current version:

### 1. Changes from V 1.00 to V 1.01

The chapter describing 'Networking Systems' has been removed, because it is now available in the document 'Hirolink for Modbus V X.XX - General Documentation' (X.XX is a placeholder for the current version of the Hirolink).

Also all descriptions regarding the 'Status-Report' have been moved to this document

## Connectivity



*the evolution*

## Hirolink for Modbus

(09) Items for CCAC (WXG - E1G - EVG) (Microface).doc

English

04/11/03 Release 1.07E

<b>1.</b>	<b>INTRODUCTION CCAC (WXG - E1G - EVG) (MICROFACE)</b> .....	<b>3</b>
<b>2.</b>	<b>COMPATIBILITY-LIST</b> .....	<b>3</b>
<b>3.</b>	<b>ITEMS FOR CCAC (WXG - E1G - EVG) (MICROFACE)</b> .....	<b>4</b>
3.1	COILS.....	4
3.2	INPUT-STATUS.....	4
3.3	HOLDING REGISTER.....	5
3.4	INPUT-REGISTER .....	7
3.5	EVENTS.....	9
3.5.1	<i>Event-Registers</i> .....	9
3.5.2	<i>Event-List</i> .....	10
<b>4.</b>	<b>DOCUMENT-CHANGES</b> .....	<b>12</b>

# 1. Introduction CCAC (WXG - E1G - EVG) (Microface)

This document contains a description of all data-points that are available via the 'Hirolink for Modbus' from this type of air-conditioner.

## **IMPORTANT:**

It is vital to the correct integration of the Hirolink into a Modbus-network, that you have read and understood the topics described in the document 'Hirolink for Modbus V X.XX - General Documentation' (X.XX is a placeholder for the current version of the Hirolink). So, if you haven't read this document until now, read it first.

# 2. Compatibility-List

Before connecting a Hiromatic to the Modbus-Hirolink you must check, if the Hiromatic-software-version is compatible with this version of the Hirolink.

You can do this by checking the labels on the eproms, which are inserted into the Hiromatic and the Microface. The eprom inserted in the Hiromatic must be called WXG + Version-Number (e.g. WXG139) or E1G + Version-Number or EVG L1/L2 + Version-Number.

To make sure that the label on the eproms is correct, you should also check the version-information, that the Hiromatic displays shortly after start-up. This information should look similar to the following illustration:

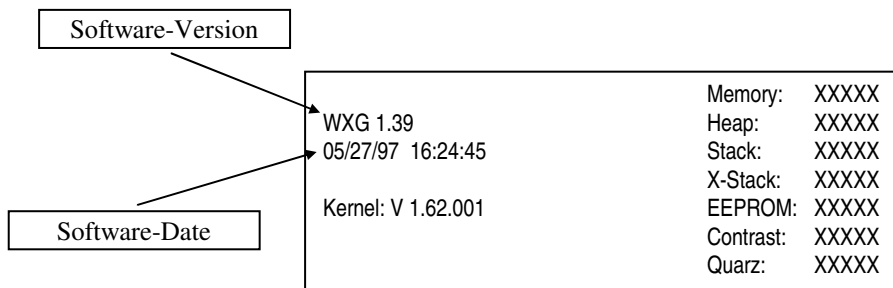

The important information in this window is only the software-version and the software-date (note that the date-format is mm/dd/yy). Make sure that the software-version installed in your installation matches one of the compatible versions listed below:

<b>Version</b>	<b>Date</b>
1.15	10/28/96
1.20	01/22/97 16:09:47
1.39	05/27/97 16:24:45
1.41.002	07/28/97 11:01:12
1.42	10/07/97 13:30:57
1.51.xxx	---
1.60.xxx	---

### 3. Items for CCAC (WXG - E1G - EVG) (Microface)

According to the Modbus-protocol-specifications the values and parameters provided by the Hiromatic are represented in 4 groups:

- Coils: Used for changeable, digital values
- Inputs: Used for not changeable, digital values
- Holding Registers: Used for changeable, analog values
- Input Registers: Used for not changeable, analog values

This Hirolink can be compatible with more than one version of this Hiromatic-type and it is possible that there have been extensions in the number of available items from one version to the next.

Therefore the column 'SW-Version' contained in the following lists provides information about the availability of each item depending on the Hiromatic-software-version. For example a entry like '1.15+' means, that this item is available from Hiromatics with software-version 1.15 and higher.

#### **IMPORTANT:**

The available data-points shown in the following chapters are numbered starting from 1, according to the Modbus-Protocol-Specification. Still some BMS start numbering the data-points from 0.

So, in case that the BMS you are using starts numbering from 0, you have to decrease the listed numbers by 1.

#### **3.1 Coils**

Not used on this Hiromatic-type.

#### **3.2 Input-Status**

Not used on this Hiromatic-type.

### 3.3 Holding Register

Register #	Usage	Range; Unit	SW-Version
1	Status-Report-Acknowledge	See explanation below	1.15+
2	HM-System On/Off	0 -> Hiromatic System Off; 1 -> Hiromatic System On	1.15+
3 -18	Single Alarm-Status (MIC 1 - 16)	See explanation below	1.15+
19-34	Single Unit System On/Off (MIC 1 - 16)	0 -> Single Unit System Off; 1 -> Single Unit System On	1.15+
35-50	Heater Working Hours (MIC 1 - 16)	0 - 32000; [h]	1.15+
51-66	Humidifier Working Hours (MIC 1 - 16)	0 - 32000; [h]	1.15+
67-82	Compressor 1 Working Hours (MIC 1 - 16)	0 - 32000; [h]	1.15+
83-98	Conditioner Working Hours (MIC 1 - 16)	0 - 32000; [h]	1.15+
99-114	Sleep Mode Reset (MIC 1 - 16)	0 -> No, 1 -> Yes, 2 -> Auto	1.15+
115-130	Sleep Mode Second Interval TO Minutes (MIC 1 - 16)	0 - 59; [min]	1.15+
131-146	Sleep Mode Second Interval TO Hours (MIC 1 - 16)	0 - 23; [h]	1.15+
147-162	Sleep Mode Second Interval FROM Minutes (MIC 1 - 16)	0 - 59; [min]	1.15+
163-178	Sleep Mode Second Interval FROM Hours (MIC 1 - 16)	0 - 23; [h]	1.15+
179-194	Sleep Mode First Interval TO Minutes (MIC 1 - 16)	0 - 59; [min]	1.15+
195-210	Sleep Mode First Interval TO Hours (MIC 1 - 16)	0 - 23; [h]	1.15+
211-226	Sleep Mode First Interval FROM Minutes (MIC 1 - 16)	0 - 59; [min]	1.15+
227-242	Sleep Mode First Interval FROM Hours (MIC 1 - 16)	0 - 23; [h]	1.15+
243-258	Low Pressure Delay Time (MIC 1 - 16)	0 - 5; [min]	1.15+
259-274	Low Humidity Warning (MIC 1 - 16)	0 -> No, 1 - 99; [%RH]	1.15+
275-290	High Humidity Warning (MIC 1 - 16)	0 -> No, 1 - 99; [%RH]	1.15+
291-306	Low Temperature Warning (MIC 1 - 16)	0 -> No, 1 - 99; [°C]	1.15+
307-322	High Temperature Warning (MIC 1 - 16)	0 -> No, 1 - 99; [°C]	1.15+
323	Number of Standby Units	0 - 16	1.15+
324-338	not used		1.15+
339-354	Humidity Integral Factor (MIC 1 - 16)	4 -> No, 5 -15; [min]	1.15+
355-370	Temperature Integral Factor (MIC 1 - 16)	4 -> No, 5 -15; [min]	1.15+
371-386	Humidity Proportional Band (MIC 1 - 16)	5 - 20; [%RH]	1.15+
387-402	Temperature Proportional Band (MIC 1 - 16)	10 - 100; [1/10 K]	1.15+
403	Shared Parameters	0 -> No, 1 -> Yes	1.15+
404-418	not used		1.15+
419-434	Fanspeed (MIC 1 - 16)	29 -> No, 30 - 100; [%]	1.15+
435-450	Supply Air Setpoint (MIC 1 - 16)	5 - 25; [°C]	1.15+
451-466	Room Humidity Setpoint (MIC 1 - 16)	19 -> No; 20 - 80; [%RH]	1.15+
467-482	Room Temperature Setpoint 1 (MIC 1 - 16)	50 - 400; [1/10 °C]	1.15+
483-498	Room Temperature Setpoint 2 (MIC 1 - 16)	4 -> No, 5 - 40; [1/10 °C]	1.30+
499-514	Compressor 2 Working Hours (MIC 1 - 16)	0 - 32000; [h]	1.30+
515-530	Freecooling Working Hours (MIC 1 - 16)	0 - 32000; [h]	1.35+
531-546	Stop Freecooling at (MIC 1 - 16)	0 -> No, 1 - 25; [K]	1.35+
547-562	Freecooling Difference between room and glycol temperature (MIC 1 - 16)	0 -> No, 1 - 25; [K]	1.35+
563-578	Freecooling Difference between room and ambient temperature (MIC 1 - 16)	0 -> No, 1 -> EFC, 1 - 25; [K]	1.35+

#### Status-Report-Acknowledge (Holding Register #1):

Read the document 'Hirolink for Modbus V X.XX - General Documentation' (X.XX is a placeholder for the current version of the Hirolink) for a description on how to use this data-point.

## Single Alarm-Status (Holding Registers #3 - #18):

This item holds a value which represents the current alarm-state of single Microface.

It can be written to in order to perform either a 'Alarm Acknowledge'- or a 'Alarm Reset'-command on a single Microface:

### 2 .. Alarm Reset:

This command will reset all alarms, warnings and messages currently present on a Microface. As a consequence alarms, warnings and messages that are inactive will disappear, will active alarms, warnings and messages will be reported again.

### 4 .. Alarm Acknowledge:

This command will acknowledge all alarms, warnings and messages present on a Microface. As a consequence alarms, warnings and messages that were in an unacknowledged state will be acknowledged after the command.

When read, the value corresponds to the following states:

0 .. No alarm present

1 .. Message acknowledged (inactive)

3 .. Message acknowledged (active)

5 .. Message not acknowledged (inactive)

7 .. Message not acknowledged (active)

9 .. Warning acknowledged (inactive)

11.. Warning acknowledged (active)

13.. Warning not acknowledged (inactive)

15.. Warning not acknowledged (active)

17.. Alarm acknowledged (inactive)

19.. Alarm acknowledged (active)

21...Alarm not acknowledged (inactive)

23.. Alarm not acknowledged (active)

25.. Alarm and warning acknowledged (inactive)

27.. Alarm and warning acknowledged (active)

29.. Alarm and warning not acknowledged (inactive)

31.. Alarm and warning not acknowledged (active)

The terms 'acknowledged' and 'not acknowledged' define, if the reset-push-button on the Hiromatic has been pressed once in order to silence the buzzer or if the command 'Alarm Acknowledge' has been performed.

The terms 'active' and 'inactive' define, if the alarm, warning or message is still active, which means that after performing a alarm-reset (either by sending the appropriate command via the Modbus-network or by pressing the reset-push-button on the Hiromatic a second time) the alarm or warning will be reported again.

### **NOTE:**

Although you can read the alarm-state of the whole system, it is not possible to issue a 'Alarm Acknowledge'- or 'Alarm Reset'-command for the whole system. Instead you have to issue these commands for each Microface separately.



### 3.4 Input-Register

Register #	Usage	Range; Unit	SW-Version
1	Event-ID	ID identifying the event	1.15+
2	Controller-ID	Controller-ID, where the event occurred	1.15+
3	Minute	Minute, when event occurred	1.15+
4	Hour	Hour, when event occurred	1.15+
5	Date	Date, when event occurred	1.15+
6	Event-Type	0 -> message, 1 -> warning, 2 -> alarm, 3 and 4 -> reset	1.15+
7	System Alarm	See explanation below	1.15+
8	System Status	See explanation below	1.15+
9-24	Cooling Ramp (MIC 1 - 16)	0 - 100; [%]	1.15+
25-40	Status Dehumidification (MIC 1 - 16)	0 -> Off, 1 -> On	1.15+
41-56	Status Electrical Heater 2 (MIC 1 - 16)	0 -> Off, 1 -> On	1.15+
57-72	Status Electrical Heater 1 (MIC 1 - 16)	0 -> Off, 1 -> On	1.15+
73-88	Status Compressor 1 (MIC 1 - 16)	0 -> Off, 1 -> On	1.15+
89-104	Status Fan (MIC 1 - 16)	0 -> Off, 1 -> On	1.15+
105	Shared Room Humidity (average of all room-humidity-sensors) (MIC 1 - 16)	0 - 100; [%RH]	1.15+
106-120	not used		1.15+
121	Shared Room Temperature (average of all room-temperature-sensors) (MIC 1 - 16)	-300 - 1000; [1/10 °C]	1.15+
122-136	not used		1.15+
137-152	Single Status (per Unit) (MIC 1 - 16)	See explanation below	1.15+
153-168	Humidifier Current	0 - 4000; [1/100 A]	1.15+
169-184	Hirotemp 1 Value 2 (MIC 1 - 16)	-300 - 1000; [1/10 °C]	1.15+
185-200	Hirotemp 1 Value 1 (MIC 1 - 16)	-300 - 1000; [1/10 °C]	1.15+
201-216	Supply Air Temperature (MIC 1 - 16)	-300 - 1000; [1/10 °C]; see explanation below	1.15+
217-232	Room Humidity (MIC 1 - 16)	0-1000; [1/10 %RH]; see explanation below	1.15+
233-248	Room Temperature (MIC 1 - 16)	-300 - 1000; [1/10 °C]; see explanation below	1.15+
249-264	Actual Temperature Setpoint (MIC 1 - 16)	50 - 400; [1/10 °C]	1.30+
265-280	Status Compressor 2 (MIC 1 - 16)	0 -> Off; 1 -> On	1.30+
281	Shared Glycol Temperature (average of all glycol-temperature-sensors ) (MIC 1 - 16)	-300 - 1000; [1/10 °C]	1.35+
282-296	not used		1.35+
297-312	Glycol Temperature (MIC 1 - 16)	-300 - 1000; [1/10 °C]	1.35+
313	Shared Outdoor Temperature (average of all outdoor-temperature-sensors ) (MIC 1 - 16)	-300 - 1000; [1/10 °C]	1.35+
314-328	not used		1.35+
329-344	Outdoor Temperature (MIC 1 - 16)	-300 - 1000; [1/10 °C]	1.35+
345-360	Freecooling Status (MIC 1 - 16)	0 -> FC Off; 1 -> FC Start; 2 -> FC On; 3 -> No FC Mode	1.35+
361-376	Radcooler Ramp (MIC 1 - 16)	0 - 100; [%]	<b>1.35+</b>
361-376	Analoge Output Ramp 2 (MIC 1 - 16) (follows the setting of the 2 <sup>nd</sup> analoge output)	0 - 100; [%]	<b>1.60.032+</b>

#### Status-Report-Block (Input Register #1 - #6):

Read the document 'Hirolink for Modbus V X.XX - General Documentation' (X.XX is a placeholder for the current version of the Hirolink) for a description on how to use these data-points.

## System-Alarm (Input Register #7):

This item holds a value, which represents the current alarm-state of the whole system. This alarm-state is calculated from the single alarm-states of each Microface and holds the highest of those alarm-states. The single alarm-states can be read using the appropriate Holding Registers.

The values correspond to the following states:

- 0 .. No alarm present
- 1 .. Message acknowledged (inactive)
- 3 .. Message acknowledged (active)
- 5 .. Message not acknowledged (inactive)
- 7 .. Message not acknowledged (active)
  
- 9 .. Warning acknowledged (inactive)
- 11 .. Warning acknowledged (active)
- 13 .. Warning not acknowledged (inactive)
- 15 .. Warning not acknowledged (active)
  
- 17 .. Alarm acknowledged (inactive)
- 19 .. Alarm acknowledged (active)
- 21 .. Alarm not acknowledged (inactive)
- 23 .. Alarm not acknowledged (active)
  
- 25 .. Alarm and warning acknowledged (inactive)
- 27 .. Alarm and warning acknowledged (active)
- 29 .. Alarm and warning not acknowledged (inactive)
- 31 .. Alarm and warning not acknowledged (active)

The terms 'acknowledged' and 'not acknowledged' define, if the reset-push-button on the Hiromatic has been pressed once in order to silence the buzzer or if the command 'Alarm Acknowledge' has been performed.

The terms 'active' and 'inactive' define, if the alarm, warning or message is still active, which means that after performing a alarm-reset (either by sending the appropriate command via the Modbus-network or by pressing the reset-push-button on the Hiromatic a second time) the alarm or warning will be reported again.

## System-Status (Input Register #8) and Single Status (Input Registers #137 - #152):

This item holds a value, which represents the current system-state of the whole system and of the single Microfaces. The values correspond to the following states:

- 0 .. Alarm Off
- 1 .. Manual
- 2 .. Local Off
- 3 .. System Off
- 4 .. Standby Alarm
- 5 .. Standby
- 6 .. Sleep / Off
- 7 .. System On
- 8 .. Warning On
- 9 .. Alarm On
- 10 .. Sleep

## Supply Air Temperature (Input Register #201 - #216), Room Temperature (Input Registers #233 - #248) and Room Humidity (Input Registers #217 - #232):

In case of NO Humitemp-sensor being used to measure the current room temperature and humidity, the 'Supply Air Temperature'-input-registers will hold the current room temperature and the 'Room Temperature' - and 'Room Humidity'-input-registers will be invalid. With Hirolink for MODBUS V 2.88, starting from the E1G and EVG EPROM applications, in case of no Humitemp, the ambient temperature can be read both in Supply Air Temperature (Input Register #201 - #216), Room Temperature (Input Registers #233 - #248) registers.

### 3.5 Events

#### 3.5.1 Event-Registers

Starting from 'HL for Modbus - V 2.85', there is the possibility to read the current state of a single event through Input-Registers, each bit of these registers represents the state of one event:

Examples:

Input-Register #5001:

State of Hiromatic-events from ID 0 to 15

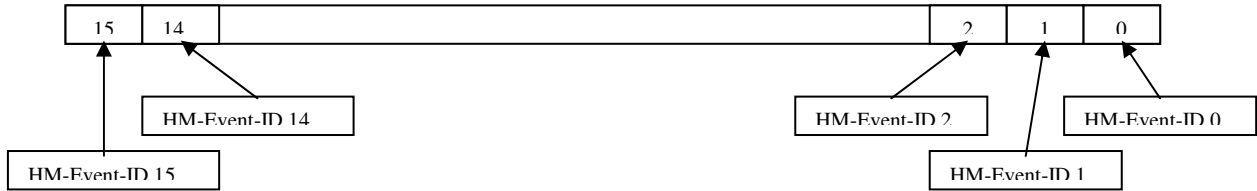

Input-Register #5009:

State of Microface-events from ID 0 to 15 from Microface with ID #1

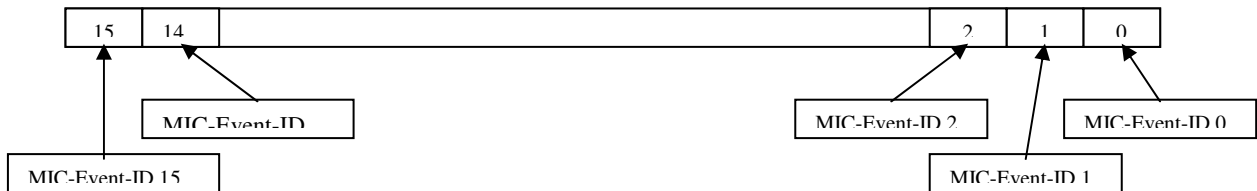

Register #	Usage
5001	Hiromatic-events #0-#15
5002	Hiromatic-events #16-#31
...	...
5008	Hiromatic-events #112-#127
5009	Microface #1-events #0-#15
5010	Microface #1-events #16-#31
...	...
5016	Microface #1-events #112-#127
5017	Microface #2-events #0-#15
5018	Microface #2-events #16-#31
...	...
5024	Microface #2-events #112-#127
...	...
5129	Microface #16-events #0-#15
5130	Microface #16-events #16-#31
...	...
5136	Microface #16-events #112-#127

The following chapter contains a list with all events available for this unit-type. Unused event-IDs will always be set to 0.

**NOTE:**

Events of type 'Message' and 'Reset' (see Event-list in the following chapter), will NOT cause a bit to be set in the Event-registers when they are reported by the Hiromatic. Furthermore, the events 'UNIT CONNECTED' (Event-ID 100) and 'UNIT NOT CONNECTED' (Event-ID 101), which are generated by the Hirolink itself, are also NOT available as single bits within the Event-registers.

These events are only available through the 'Status Report Block' (Input registers #1 - #6).

**For these controls boards and its applications the event registers are upgraded only if the 'Status-Report-Acknowledge' jumper is set; so Hirolink does the upgrades mandatorily** (for more information see Modbus General Documentatio Chapter '5.4 The Status-Report').

### 3.5.2 Event-List

**IMPORTANT:**

If you intend to read the current events through the ‘Status Report Block’ (Input-Registers #1 -#6), please read the document ‘Hirolink for Modbus V X.XX - General Documentation’ (X.XX is a placeholder for the current version of the Hirolink) for a detailed description on how to use these data-points.

In the following list you can see all Events and Event-IDs available for WXG-units:

Event-ID	Event-Description	Event-Type	SW-Version
0	GENERAL ALARM	Reset	1.15+
1	COMPRESSOR 1 HIGH PRESSURE	Alarm	1.15+
2	COMPRESSOR 1 LOW PRESSURE	Alarm	1.15+
3	HIGH CHILLED WATER TEMPERATURE	Warning	1.15+
4	LOW CHILLED WATER FLOW	Warning	1.15+
5	ELECTRICAL HEATERS OVERHEATED	Warning	1.15+
6	FAN FAILURE	Warning	1.15+
7	FAN FAILURE	Alarm	1.15+
8	CLOGGED FILTERS	Warning	1.15+
9	WATER LEAKAGE DETECTED	Warning	1.15+
10	WATER LEAKAGE DETECTED	Alarm	1.15+
11	USER INPUT TRIGGERED	Warning	1.15+
12	USER INPUT TRIGGERED	Alarm	1.15+
13	EXTERNAL HUMIDIFIER FAILURE	Warning	1.15+
14	HUMIDIFIER HIGH CURRENT	Warning	1.15+
15	HUMIDIFIER FAILURE	Warning	1.15+
16	HUMIDIFIER FAILURE	Warning	1.15+
17	HUMIDIFIER CYLINDER WARNING	Warning	1.15+
18	HIGH ROOM TEMPERATURE	Warning	1.15+
19	LOW ROOM TEMPERATURE	Warning	1.15+
20	HIGH ROOM HUMIDITY	Warning	1.15+
21	LOW ROOM HUMIDITY	Warning	1.15+
22	HIGH ROOM TEMPERATURE (EEAP)	Warning	1.15+
23	LOW ROOM TEMPERATURE (EEAP)	Warning	1.15+
24	HIGH ROOM HUMIDITY (EEAP)	Warning	1.15+
25	LOW ROOM HUMIDITY (EEAP)	Warning	1.15+
26	CONDITIONER WORKING HOURS EXCEEDED	Warning	1.15+
27	COMPRESSOR 1 WORKING HOURS EXCEEDED	Warning	1.15+
28	HUMIDIFIER WORKING HOURS EXCEEDED	Warning	1.15+
29	PTC SENSOR FAILURE	Warning	1.15+
30	ROOM SENSOR FAILURE	Warning	1.15+
31	ROOM SENSOR FAILURE	Alarm	1.15+
32	EEAP SENSOR FAILURE	Warning	1.15+
33	WATER PRESENCE SENSOR FAILURE	Warning	1.15+
34	NETWORK FAILURE	Warning	1.15+
35	OUT OF MEMORY	Warning	1.15+
36	UNIT ON	Message	1.15+
37	UNIT OFF	Message	1.15+
38	SLEEP MODE	Message	1.15+
39	STANDBY MODE	Message	1.15+
40	POWER ON	Message	1.15+
41	POWER OFF	Message	1.15+
42	UNIT 1 DISCONNECTED	Alarm	1.15+
43	UNIT 2 DISCONNECTED	Alarm	1.15+
44	UNIT 3 DISCONNECTED	Alarm	1.15+
45	UNIT 4 DISCONNECTED	Alarm	1.15+
46	UNIT 5 DISCONNECTED	Alarm	1.15+
47	UNIT 6 DISCONNECTED	Alarm	1.15+

48	UNIT 7 DISCONNECTED	Alarm	1.15+
49	UNIT 8 DISCONNECTED	Alarm	1.15+
50	UNIT 9 DISCONNECTED	Alarm	1.15+
51	UNIT 10 DISCONNECTED	Alarm	1.15+
52	UNIT 11 DISCONNECTED	Alarm	1.15+
53	UNIT 12 DISCONNECTED	Alarm	1.15+
54	UNIT 13 DISCONNECTED	Alarm	1.15+
55	UNIT 14 DISCONNECTED	Alarm	1.15+
56	UNIT 15 DISCONNECTED	Alarm	1.15+
57	UNIT 16 DISCONNECTED	Alarm	1.15+
58	COMPRESSOR 2 HIGH PRESSURE	Alarm	1.20+
59	COMPRESSOR 2 LOW PRESSURE	Alarm	1.20+
60	COMPRESSOR 2 WORKING HOURS EXCEEDED	Warning	1.20+
61	OUTDOOR TEMPERATURE SENSOR FAILURE	Warning	1.20+
62	GLYCOL TEMPERATURE SENSOR FAILURE	Warning	1.20+
63	FREECOOLING STOPPED FOR 1 HOUR	Message	1.20+
64	ON-OFF BY HIROMATIC NOT ENABLED	Warning	1.60+
65	SMOKE ALARM	Warning	1.60+
66	NO POWER (USER INPUT)	Message	1.60+
67	POWER ON (USER INPUT)	Message	1.60+
68	USER INPUT 2 TRIGGERED	Warning	1.60+
69	USER INPUT 2 TRIGGERED	Alarm	1.60+
70	NO CONNECTION TO UNIT 1	Warning	1.60+
71	COMPRESSOR 1 MOTOR PROTECTION	Alarm	1.60+
72	COMPRESSOR 2 MOTOR PROTECTION	Alarm	1.60+
73	FIRE ALARM	Alarm	1.60+
74	OUT OF MEMORY	Warning	1.60+
75	CONDENSER 1 FAN FAILURE	Warning	1.60+
76	CONDENSER 2 FAN FAILURE	Warning	1.60+
77	HIROBUS ERROR	Warning	1.60+
78	SUBGROUP-ID NOT UNIQUE	Warning	1.60+
79	SUBGROUP-UNIT 1 NOT CONNECTED	Warning	1.60+
80	SUBGROUP-UNIT 2 NOT CONNECTED	Warning	1.60+
81	SHARE ROOM SENSOR FAILURE	Warning	1.60+
82	SHARE ROOM SENSOR FAILURE	Alarm	1.60+
83	SHARE OUTDOOR TEMP. SENSOR	Warning	1.60+
84	SHARE GLYCOL TEMP. SENSOR	Warning	1.60+
85	UNIT SYNCHRONISATION (=Short Reset)	Message	1.60+
86	HUMIDIFIER HIGH TEMPERATURE	Alarm	1.60+
87	HUMIDIFIER OVERFLOW	Alarm	1.60+
88	HEATER 1/2 WORKING HOURS EXCEEDED	Alarm	1.60+
89	FREECOOLING WORKING HOURS EXCEEDED	Alarm	1.60+
90	AIRFLOW DEVICE NOT READY, PLS. CHECK	Alarm	1.60+
100	UNIT CONNECTED	Message	1.15+
101	UNIT NOT CONNECTED	Message	1.15+

## 4. Document-Changes

This appendix contains all changes that have been applied to this document up to the current version:

### 1. Changes from V 1.00 to V 1.01

- The chapter describing 'Networking Systems' has been removed, because it is now available in the document 'Hirolink for Modbus V X.XX - General Documentation' (X.XX is a placeholder for the current version of the Hirolink).
- Also all descriptions regarding the 'Status-Report' have been moved to this document.

### 2. Changes from V 1.01 to V 1.02

- The description of the Holding Registers #563-#578 was corrected (a value of 1 sets this parameter to 'EFC').

### 3. Changes from V 1.02 to V 1.03

- The order of the input registers 313 'Shared outdoor temperature' and 329-344 'Outdoor temperature' was corrected.

### 4. Changes from V 1.03 to V 1.04

- Explanation of input-registers 'Supply Air Temperature', 'Room Temperature' and 'Room Humidity' added.

### 5. Changes from V 1.04 to V 1.05

- Upgrade of the Event list.

### 6. Changes from V 1.05 to V 1.06

- A note regarding the ambient temperature sensor has been added to the chapter 3.4.

### 7. Changes from V 1.06 to V 1.07

- Events description for 88,89 and 90 corrected.
- Input register 361 – 376 updated for eeprom version 1.60.032.

# Connectivity

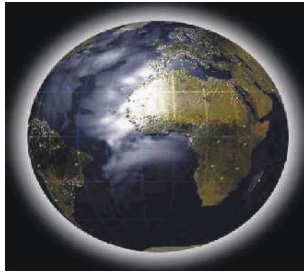

*the evolution*

## Hirolink for Modbus

(10) Items for Hiwall (HWG) (Microface).doc

English

04/11/03 Release 1.01E

<b>1.</b>	<b>INTRODUCTION HIWALL (HWG) (MICROFACE)</b> .....	<b>3</b>
<b>2.</b>	<b>COMPATIBILITY-LIST</b> .....	<b>3</b>
<b>3.</b>	<b>ITEMS FOR HIWALL (HWG) (MICROFACE)</b> .....	<b>4</b>
3.1	COILS .....	4
3.2	INPUT-STATUS .....	4
3.3	HOLDING REGISTER .....	5
3.4	INPUT-REGISTER.....	7
3.5	EVENTS .....	9
<b>4.</b>	<b>DOCUMENT-CHANGES</b> .....	<b>10</b>



# 1. Introduction Hiwall (HWG) (Microface)

This document contains a description of all data-points that are available via the 'Hirolink for Modbus' from this type of air-conditioner.

## **IMPORTANT:**

It is vital to the correct integration of the Hirolink into a Modbus-network, that you have read and understood the topics described in the document 'Hirolink for Modbus V X.XX - General Documentation' (X.XX is a placeholder for the current version of the Hirolink). So, if you haven't read this document until now, read it first.

# 2. Compatibility-List

Before connecting a Hiromatic to the Modbus-Hirolink you must check, if the Hiromatic-software-version is compatible with this version of the Hirolink.

You can do this by checking the labels on the eproms, which are inserted into the Hiromatic and the Microface. The eprom inserted in the Hiromatic must be called HWG + Version-Number (e.g. HWG120) and the one inserted in the Microface must be called HWM + Version-Number (e.g. HWM120).

To make sure that the label on the eproms is correct, you should also check the version-information, that the Hiromatic displays shortly after start-up. This information should look similar to the following illustration:

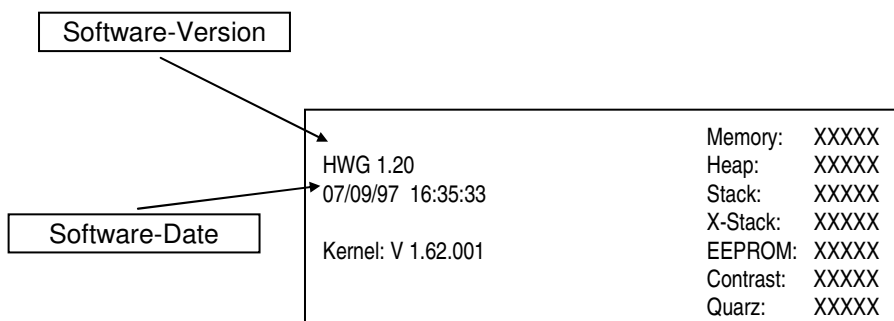

The important information in this window is only the software-version and the software-date (note that the date-format is mm/dd/yy). Make sure that the software-version installed in your installation matches one of the compatible versions listed below:

<b>Version</b>	<b>Date</b>
1.12	02/21/97 16:21:57
1.20	07/09/97 16:35:33

### 3. Items for Hiwall (HWG) (Microface)

According to the Modbus-protocol-specifications the values and parameters provided by the Hiromatic are represented in 4 groups:

- Coils: Used for changeable, digital values
- Inputs: Used for not changeable, digital values
- Holding Registers: Used for changeable, analog values
- Input Registers: Used for not changeable, analog values

This Hirolink can be compatible with more than one version of this Hiromatic-type and it is possible that there have been extensions in the number of available items from one version to the next.

Therefore the column 'SW-Version' contained in the following lists provides information about the availability of each item depending on the Hiromatic-software-version. For example a entry like '1.12+' means, that this item is available from Hiromatics with software-version 1.12 and higher.

#### **IMPORTANT:**

The available data-points shown in the following chapters are numbered starting from 1, according to the Modbus-Protocol-Specification. Still some BMS start numbering the data-points from 0. So, in case that the BMS you are using starts numbering from 0, you have to decrease the listed numbers by 1.

#### **3.1 Coils**

Not used on this Hiromatic-type.

#### **3.2 Input-Status**

Not used on this Hiromatic-type.

### 3.3 Holding Register

Register #	Usage	Range; Unit	SW-Version
1	Status-Report-Acknowledge	See explanation below	1.12+
2	HM-System On/Off	0 -> Hiromatic System Off; 1 -> Hiromatic System On	1.12+
3 -18	Single Alarm-Status (MIC 1 - 16)	See explanation below	1.12+
19-34	Single Unit System On/Off (MIC 1 - 16)	0 -> Single Unit System Off; 1 -> Single Unit System On	1.12+
35-50	Heater Working Hours (MIC 1 - 16)	0 - 32000; [h]	1.12+
51-66	Humidifier Working Hours (MIC 1 - 16)	0 - 32000; [h]	1.12+
67-82	Compressor 1 Working Hours (MIC 1 - 16)	0 - 32000; [h]	1.12+
83-98	Conditioner Working Hours (MIC 1 - 16)	0 - 32000; [h]	1.12+
99-114	Sleep Mode Reset (MIC 1 - 16)	0 -> No, 1 -> Yes	1.12+
115-130	Sleep Mode Second Interval TO Minutes (MIC 1 - 16)	0 - 59; [min]	1.12+
131-146	Sleep Mode Second Interval TO Hours (MIC 1 - 16)	0 - 23; [h]	1.12+
147-162	Sleep Mode Second Interval FROM Minutes (MIC 1 - 16)	0 - 59; [min]	1.12+
163-178	Sleep Mode Second Interval FROM Hours (MIC 1 - 16)	0 - 23; [h]	1.12+
179-194	Sleep Mode First Interval TO Minutes (MIC 1 - 16)	0 - 59; [min]	1.12+
195-210	Sleep Mode First Interval TO Hours (MIC 1 - 16)	0 - 23; [h]	1.12+
211-226	Sleep Mode First Interval FROM Minutes (MIC 1 - 16)	0 - 59; [min]	1.12+
227-242	Sleep Mode First Interval FROM Hours (MIC 1 - 16)	0 - 23; [h]	1.12+
243-258	Low Pressure Delay Time (MIC 1 - 16)	0 - 5; [min]	1.12+
259-274	Low Humidity Warning (MIC 1 - 16)	0 -> No, 1 - 99; [%RH]	1.12+
275-290	High Humidity Warning (MIC 1 - 16)	0 -> No, 1 - 99; [%RH]	1.12+
291-306	Low Temperature Warning (MIC 1 - 16)	0 -> No, 1 - 99; [°C]	1.12+
307-322	High Temperature Warning (MIC 1 - 16)	0 -> No, 1 - 99; [°C]	1.12+
323	Number of Standby Units	0 - 16	1.12+
324-338	not used		1.12+
339-354	Humidity Integral Factor (MIC 1 - 16)	4 -> No, 5 -15; [min]	1.12+
355-370	Temperature Integral Factor (MIC 1 - 16)	4 -> No, 5 -15; [min]	1.12+
371-386	Humidity Proportional Band (MIC 1 - 16)	5 - 20; [%RH]	1.12+
387-402	Temperature Proportional Band (MIC 1 - 16)	10 - 100; [1/10 K]	1.12+
403	Shared Parameters	0 -> No, 1 -> Yes	1.12+
404-418	not used		1.12+
419-434	Fanspeed (MIC 1 - 16)	29 -> No, 30 - 100; [%]	1.12+
435-450	Supply Air Setpoint (MIC 1 - 16)	5 - 25; [°C]	1.12+
451-466	Room Humidity Setpoint (MIC 1 - 16)	19 -> No; 20 - 80; [%RH]	1.12+
467-482	Room Temperature Setpoint 1 (MIC 1 - 16)	50 - 400; [1/10 °C]	1.12+
483-498	Freecooling Delay Time (MIC 1 - 16)	0 -> No; 1 - 25; [min]	1.12+
499-514	Freecooling Difference between room- and ambient - temperature (MIC 1 - 16)	0 -> No; 1 - 25; [K]	1.12+
515-530	Freecooling Working Hours (MIC 1 - 16)	0 - 32000; [h]	1.12+
531-546	Stop Freecooling at (MIC 1 - 16)	0 -> No, 1 - 25; [K]	1.12+
547-562	Freecooling Difference between room and glycol temperature (MIC 1 - 16)	0 -> No, 1 - 25; [K]	1.12+
563-578	Freecooling Difference between room and ambient temperature (MIC 1 - 16)	0 -> No, 1 - 25; [K]	1.12+

## Status-Report-Acknowledge (Holding Register #1):

Read the document 'Hirolink for Modbus V X.XX - General Documentation' (X.XX is a placeholder for the current version of the Hirolink) for a description on how to use this data-point.

## Single Alarm-Status (Holding Registers #3 - #18):

This item holds a value which represents the current alarm-state of single Microface.

It can be written to in order to perform either a 'Alarm Acknowledge'- or a 'Alarm Reset'-command on a single Microface:

- 2 .. Alarm Reset:  
This command will reset all alarms, warnings and messages currently present on a Microface. As a consequence alarms, warnings and messages that are inactive will disappear, will active alarms, warnings and messages will be reported again.
- 4 .. Alarm Acknowledge:  
This command will acknowledge all alarms, warnings and messages present on a Microface. As a consequence alarms, warnings and messages that were in an unacknowledged state will be acknowledged after the command.

When read, the value corresponds to the following states:

- 0 .. No alarm present
- 1 .. Message acknowledged (inactive)
- 3 .. Message acknowledged (active)
- 5 .. Message not acknowledged (inactive)
- 7 .. Message not acknowledged (active)
- 9 .. Warning acknowledged (inactive)
- 11.. Warning acknowledged (active)
- 13.. Warning not acknowledged (inactive)
- 15.. Warning not acknowledged (active)
- 17.. Alarm acknowledged (inactive)
- 19.. Alarm acknowledged (active)
- 21.. Alarm not acknowledged (inactive)
- 23.. Alarm not acknowledged (active)
- 25.. Alarm and warning acknowledged (inactive)
- 27.. Alarm and warning acknowledged (active)
- 29.. Alarm and warning not acknowledged (inactive)
- 31.. Alarm and warning not acknowledged (active)

The terms 'acknowledged' and 'not acknowledged' define, if the reset-push-button on the Hiromatic has been pressed once in order to silence the buzzer or if the command 'Alarm Acknowledge' has been performed.

The terms 'active' and 'inactive' define, if the alarm, warning or message is still active, which means that after performing a alarm-reset (either by sending the appropriate command via the Modbus-network or by pressing the reset-push-button on the Hiromatic a second time) the alarm or warning will be reported again.

### **NOTE:**

Although you can read the alarm-state of the whole system, it is not possible to issue a 'Alarm Acknowledge'- or 'Alarm Reset'-command for the whole system. Instead you have to issue these commands for each Microface separately.

### 3.4 Input-Register

Register #	Usage	Range; Unit	SW-Version
1	Event-ID	ID identifying the event	1.12+
2	Controller-ID	Controller-ID, where the event occurred	1.12+
3	Minute	Minute, when event occurred	1.12+
4	Hour	Hour, when event occurred	1.12+
5	Date	Date, when event occurred	1.12+
6	Event-Type	0 -> message, 1 -> warning, 2 -> alarm, 3 and 4 -> reset	1.12+
7	System Alarm	See explanation below	1.12+
8	System Status	See explanation below	1.12+
9-24	Cooling Ramp (MIC 1 - 16)	0 - 100; [%]	1.12+
25-40	Status Dehumidification (MIC 1 - 16)	0 -> Off, 1 -> On	1.12+
41-56	Status Electrical Heater 2 (MIC 1 - 16)	0 -> Off, 1 -> On	1.12+
57-72	Status Electrical Heater 1 (MIC 1 - 16)	0 -> Off, 1 -> On	1.12+
73-88	Status Compressor 1 (MIC 1 - 16)	0 -> Off, 1 -> On	1.12+
89-104	Status Fan (MIC 1 - 16)	0 -> Off, 1 -> On	1.12+
105	Shared Room Humidity (average of all room-humidity-sensors) (MIC 1 - 16)	0 - 100; [%RH]	1.12+
106-120	not used		1.12+
121	Shared Room Temperature (average of all room-temperature-sensors) (MIC 1 - 16)	-300 - 1000; [1/10 °C]	1.12+
122-136	not used		1.12+
137-152	Single Status (per Unit) (MIC 1 - 16)	See explanation below	1.12+
153-168	Humidifier Current	0 - 4000; [1/100 A]	1.12+
169-184	Hirotemp 1 Value 2 (MIC 1 - 16)	-300 - 1000; [1/10 °C]	1.12+
185-200	Hirotemp 1 Value 1 (MIC 1 - 16)	-300 - 1000; [1/10 °C]	1.12+
201-216	Supply Air Temperature (MIC 1 - 16)	-300 - 1000; [1/10 °C]	1.12+
217-232	Room Humidity (MIC 1 - 16)	0 - 100; [%RH]	1.12+
233-248	Room Temperature (MIC 1 - 16)	-300 - 1000; [1/10 °C]	1.12+
249-264	Ambient Temperature (MIC 1 - 16)	-300 - 1000; [1/10 °C]	1.12+
265	Shared Ambient Temperature (average of all ambient-temperature-sensors) (MIC 1 - 16)	-300 - 1000; [1/10 °C]	1.12+
266-280	not used		1.12+

### Status-Report-Block (Input Register #1 - #6):

Read the document 'Hirolink for Modbus V X.XX - General Documentation' (X.XX is a placeholder for the current version of the Hirolink) for a description on how to use these data-points.

### System-Alarm (Input Register #7):

This item holds a value, which represents the current alarm-state of the whole system. This alarm-state is calculated from the single alarm-states of each Microface and holds the highest of those alarm-states. The single alarm-states can be read using the appropriate Holding Registers.

The values correspond to the following states:

- 0 .. No alarm present
- 1 .. Message acknowledged (inactive)
- 3 .. Message acknowledged (active)
- 5 .. Message not acknowledged (inactive)
- 7 .. Message not acknowledged (active)
  
- 9 .. Warning acknowledged (inactive)
- 11 .. Warning acknowledged (active)
- 13 .. Warning not acknowledged (inactive)
- 15 .. Warning not acknowledged (active)
  
- 17 .. Alarm acknowledged (inactive)
- 19 .. Alarm acknowledged (active)
- 21 .. Alarm not acknowledged (inactive)
- 23 .. Alarm not acknowledged (active)
  
- 25 .. Alarm and warning acknowledged (inactive)
- 27 .. Alarm and warning acknowledged (active)
- 29 .. Alarm and warning not acknowledged (inactive)
- 31 .. Alarm and warning not acknowledged (active)

The terms 'acknowledged' and 'not acknowledged' define, if the reset-push-button on the Hiromatic has been pressed once in order to silence the buzzer or if the command 'Alarm Acknowledge' has been performed.

The terms 'active' and 'inactive' define, if the alarm, warning or message is still active, which means that after performing a alarm-reset (either by sending the appropriate command via the Modbus-network or by pressing the reset-push-button on the Hiromatic a second time) the alarm or warning will be reported again.

### System-Status (Inp. Register #8) and Single Status (Inp. Registers #137 - #152):

This item holds a value, which represents the current system-state of the whole system and of the single Microfaces. The values correspond to the following states:

- 0 .. Alarm Off
- 1 .. Manual
- 2 .. Local Off
- 3 .. System Off
- 4 .. Standby Alarm
- 5 .. Standby
- 6 .. Sleep / Off
- 7 .. System On
- 8 .. Warning On
- 9 .. Alarm On
- 10 .. Sleep

### 3.5 Events

#### **IMPORTANT:**

Read the document 'Hirolink for Modbus V X.XX - General Documentation' (X.XX is a placeholder for the current version of the Hirolink) for a detailed description on how to use these data-points.

In the following list you can see all Events and Event-IDs available for Hiwall-units:

Event-ID	Event-Description	Event-Type	SW-Version
0	GENERAL ALARM	Reset	1.12+
1	COMPRESSOR HIGH PRESSURE	Alarm	1.12+
2	COMPRESSOR LOW PRESSURE	Alarm	1.12+
3	HIGH CHILLED WATER TEMPERATURE	Warning	1.12+
4	LOW CHILLED WATER FLOW	Warning	1.12+
5	ELECTRICAL HEATERS OVERHEATED	Warning	1.12+
6	FAN FAILURE	Warning	1.12+
7	FAN FAILURE	Alarm	1.12+
8	CLOGGED FILTERS	Warning	1.12+
9	WATER LEAKAGE DETECTED	Warning	1.12+
10	WATER LEAKAGE DETECTED	Alarm	1.12+
11	USER INPUT TRIGGERED	Warning	1.12+
12	USER INPUT TRIGGERED	Alarm	1.12+
13	EXTERNAL HUMIDIFIER FAILURE	Warning	1.12+
14	HUMIDIFIER HIGH CURRENT	Warning	1.12+
15	HUMIDIFIER FAILURE	Warning	1.12+
16	HUMIDIFIER FAILURE	Warning	1.12+
17	HUMIDIFIER CYLINDER WARNING	Warning	1.12+
18	HIGH ROOM TEMPERATURE	Warning	1.12+
19	LOW ROOM TEMPERATURE	Warning	1.12+
20	HIGH ROOM HUMIDITY	Warning	1.12+
21	LOW ROOM HUMIDITY	Warning	1.12+
22	HIGH ROOM TEMPERATURE (EEAP)	Warning	1.12+
23	LOW ROOM TEMPERATURE (EEAP)	Warning	1.12+
24	HIGH ROOM HUMIDITY (EEAP)	Warning	1.12+
25	LOW ROOM HUMIDITY (EEAP)	Warning	1.12+
26	CONDITIONER WORKING HOURS EXCEEDED	Warning	1.12+
27	COMPRESSOR WORKING HOURS EXCEEDED	Warning	1.12+
28	HUMIDIFIER WORKING HOURS EXCEEDED	Warning	1.12+
29	PTC SENSOR FAILURE	Warning	1.12+
30	ROOM SENSOR FAILURE	Warning	1.12+
31	ROOM SENSOR FAILURE	Alarm	1.12+
32	EEAP SENSOR FAILURE	Warning	1.12+
33	WATER PRESENCE SENSOR FAILURE	Warning	1.12+
34	NETWORK FAILURE	Warning	1.12+
35	OUT OF MEMORY	Warning	1.12+
36	UNIT ON	Message	1.12+
37	UNIT OFF	Message	1.12+
38	SLEEP MODE	Message	1.12+
39	STANDBY MODE	Message	1.12+
40	POWER ON	Message	1.12+
41	POWER OFF	Message	1.12+

42	UNIT 1 DISCONNECTED	Alarm	1.12+
43	UNIT 2 DISCONNECTED	Alarm	1.12+
44	UNIT 3 DISCONNECTED	Alarm	1.12+
45	UNIT 4 DISCONNECTED	Alarm	1.12+
46	UNIT 5 DISCONNECTED	Alarm	1.12+
47	UNIT 6 DISCONNECTED	Alarm	1.12+
48	UNIT 7 DISCONNECTED	Alarm	1.12+
49	UNIT 8 DISCONNECTED	Alarm	1.12+
50	UNIT 9 DISCONNECTED	Alarm	1.12+
51	UNIT 10 DISCONNECTED	Alarm	1.12+
52	UNIT 11 DISCONNECTED	Alarm	1.12+
53	UNIT 12 DISCONNECTED	Alarm	1.12+
54	UNIT 13 DISCONNECTED	Alarm	1.12+
55	UNIT 14 DISCONNECTED	Alarm	1.12+
56	UNIT 15 DISCONNECTED	Alarm	1.12+
57	UNIT 16 DISCONNECTED	Alarm	1.12+
58	OUTDOOR TEMPERATURE SENSOR FAILURE	Warning	1.20+
59	FREECOOLING STOPPED FOR 1 HOUR	Message	1.20+
60	NO POWER (USER INPUT #1)	Message	1.20+
61	POWER ON (USER INPUT #1)	Message	1.20+

100	UNIT CONNECTED	Message	1.12+
101	UNIT NOT CONNECTED	Message	1.12+

#### 4. Document-Changes

This appendix contains all changes that have been applied to this document up to the current version:

##### 1. Changes from V 1.00 to V 1.01

The chapter describing 'Networking Systems' has been removed, because it is now available in the document 'Hirolink for Modbus V X.XX - General Documentation' (X.XX is a placeholder for the current version of the Hirolink).

Also all descriptions regarding the 'Status-Report' have been moved to this document.



## Connectivity



*the evolution*

## Hirolink for Modbus

(11) Items for Telecom Italia (TIG) (Microface).doc

English

04/11/03 Release 1.01E

<b>1.</b>	<b>INTRODUCTION TELECOM ITALIA (TIG) (MICROFACE)</b> .....	<b>3</b>
<b>2.</b>	<b>COMPATIBILITY-LIST</b> .....	<b>3</b>
<b>3.</b>	<b>ITEMS FOR TELECOM ITALIA (TIG) (MICROFACE)</b> .....	<b>4</b>
3.1	COILS .....	4
3.2	INPUT-STATUS .....	4
3.3	HOLDING REGISTER .....	5
3.4	INPUT-REGISTER .....	7
3.5	EVENTS .....	10
<b>4.</b>	<b>DOCUMENT-CHANGES</b> .....	<b>11</b>

# 1. Introduction Telecom Italia (TIG) (Microface)

This document contains a description of all data-points that are available via the 'Hirolink for Modbus' from this type of air-conditioner.

## **IMPORTANT:**

It is vital to the correct integration of the Hirolink into a Modbus-network, that you have read and understood the topics described in the document 'Hirolink for Modbus V X.XX - General Documentation' (X.XX is a placeholder for the current version of the Hirolink). So, if you haven't read this document until now, read it first.

# 2. Compatibility-List

Before connecting a Hiromatic to the Modbus-Hirolink you must check, if the Hiromatic-software-version is compatible with this version of the Hirolink.

You can do this by checking the labels on the eproms, which are inserted into the Hiromatic and the Microface. The eprom inserted in the Hiromatic must be called TIG + Version-Number (e.g. TIG101) and the one inserted in the Microface must be called TIM + Version-Number (e.g. TIM101).

To make sure that the label on the eproms is correct, you should also check the version-information, that the Hiromatic displays shortly after start-up. This information should look similar to the following illustration:

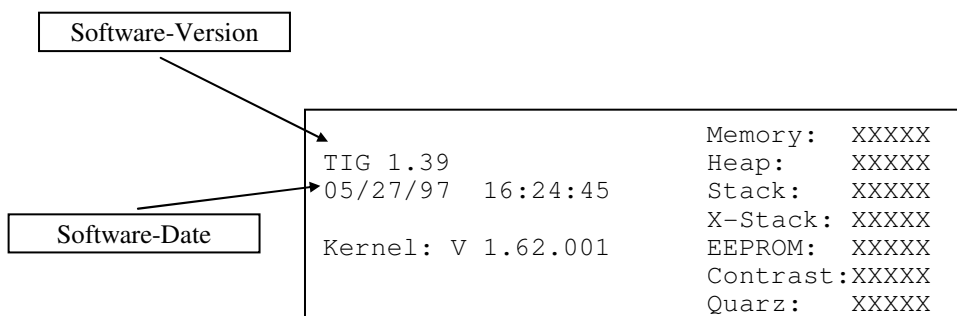

The important information in this window is only the software-version and the software-date (note that the date-format is mm/dd/yy). Make sure that the software-version installed in your installation matches one of the compatible versions listed below:

<b>Version</b>	<b>Date</b>
1.01	?

### 3. Items for Telecom Italia (TIG) (Microface)

According to the Modbus-protocol-specifications the values and parameters provided by the Hiromatic are represented in 4 groups:

- Coils: Used for changeable, digital values
- Inputs: Used for not changeable, digital values
- Holding Registers: Used for changeable, analog values
- Input Registers: Used for not changeable, analog values

This Hirolink can be compatible with more than one version of this Hiromatic-type and it is possible that there have been extensions in the number of available items from one version to the next.

Therefore the column 'SW-Version' contained in the following lists provides information about the availability of each item depending on the Hiromatic-software-version. For example a entry like '1.15+' means, that this item is available from Hiromatics with software-version 1.15 and higher.

#### **IMPORTANT:**

The available data-points shown in the following chapters are numbered starting from 1, according to the Modbus-Protocol-Specification. Still some BMS start numbering the data-points from 0. So, in case that the BMS you are using starts numbering from 0, you have to decrease the listed numbers by 1.

#### **3.1 Coils**

Not used on this Hiromatic-type.

#### **3.2 Input-Status**

Not used on this Hiromatic-type.

### 3.3 Holding Register

Register #	Usage	Range; Unit	SW-Version
1	Status-Report-acknowledge	See explanation below	1.01+
2	HM-system on/off	0 -> Hiromatic System Off; 1 -> Hiromatic System On	1.01+
3	HM alarm-status	See explanation below	1.01+
4	Number of units	1 - 16;	1.01+
5	Seconds of real time clock	0 - 59; [s]	1.01+
6	Minutes of real time clock	0 - 59; [min]	1.01+
7	Hours of real time clock	0 - 23; [h]	1.01+
8	Day of real time clock	1 - 31;	1.01+
9	Month of real time clock	1 - 12;	1.01+
10	Year of real time clock	0 - 99;	1.01+
11-26	Single unit system on/off (MIC 1 - 16)	0 -> Single Unit System Off; 1 -> Single Unit System On	1.01+
27-42	Single alarm-status (MIC 1 - 16)	See explanation below	1.01+
43-58	Room temperature setpoint (MIC 1 - 16)	50 - 400; [1/10 °C]	1.01+
59-74	Room humidity setpoint (MIC 1 - 16)	19 -> No; 20 - 80; [%RH]	1.01+
75-90	Supply air setpoint (MIC 1 - 16)	5 - 25; [°C]	1.01+
91-106	Condenser setpoint (MIC 1 - 16)		1.01+
107-122	Temperature proportional band (MIC 1 - 16)	10 - 100; [1/10 K]	1.01+
123-138	Humidity proportional band (MIC 1 - 16)	5 - 20; [%RH]	1.01+
139-154	Condenser proportional band (MIC 1 - 16)		1.01+
155-170	Temperature integral factor (MIC 1 - 16)	4 -> No, 5 -15; [min]	1.01+
171-186	Humidity integral factor (MIC 1 - 16)	4 -> No, 5 -15; [min]	1.01+
187-202	Condenser minimum speed (MIC 1 - 16)		1.01+
203-218	Freecooling difference between room and ambient temperature (MIC 1 - 16)	0 -> No, 1 -> EFC, 1 - 25; [K]	1.01+
219-234	Stop freecooling at (MIC 1 - 16)	0 -> No, 1 - 25; [K]	1.01+
235	Shared parameters enabled	0 -> No, 1 -> Yes	1.01+
236-250	Not used		1.01+
251	Cascade enabled	0 -> No, 1 -> Yes	1.01+
252-266	Not used		1.01+
267-282	Auto-restart time		1.01+
283-298	Hiromatic on/off enabled	0 -> No, 1 -> Yes	1.01+
299	Number of Standby Units	0 - 16	1.01+
300-314	Not used		1.01+
315	Rotation enabled	0 -> No, 1 -> Yes	1.01+
316-330	Not used		1.01+
331	Rotation hour	0 - 23; [h]	1.01+
332-346	Not used		1.01+
347	Rotation minute	0 - 59; [min]	1.01+
348-362	Not used		1.01+
363	Perform rotation	See explanation below	1.01+
364-378	Not used		1.01+
379-394	Low temperature warning (MIC 1 - 16)	0 -> No, 1 - 99; [°C]	1.01+
395-410	High temperature warning (MIC 1 - 16)	0 -> No, 1 - 99; [°C]	1.01+
411-426	Low humidity warning (MIC 1 - 16)	0 -> No, 1 - 99; [%RH]	1.01+
427-442	High humidity warning (MIC 1 - 16)	0 -> No, 1 - 99; [%RH]	1.01+
443-458	Low temperature alarm (MIC 1 - 16)	0 -> No, 1 - 99; [°C]	1.01+
459-474	High temperature alarm (MIC 1 - 16)	0 -> No, 1 - 99; [°C]	1.01+
475-490	Low humidity alarm (MIC 1 - 16)	0 -> No, 1 - 99; [%RH]	1.01+
491-506	High humidity alarm (MIC 1 - 16)	0 -> No, 1 - 99; [%RH]	1.01+
507-522	Low Pressure Delay Time (MIC 1 - 16)	0 - 5; [min]	1.01+
523-538	User input selection	0 - 3;	1.01+
539-554	Compressor high pressure warning level	100 - 300; [1/10 bar]	1.01+

555-570	Fan failure warning/alarm	0 -> Warning, 1 -> Alarm	1.01+
571-586	Liquistat warning/alarm	0 -> Warning, 1 -> Alarm	1.01+
587-602	Conditioner working hours (MIC 1 - 16)	0 – 32000; [h]	1.01+
603-618	Compressor working hours (MIC 1 - 16)	0 – 32000; [h]	1.01+
619-634	Humidifier working hours (MIC 1 - 16)	0 – 32000; [h]	1.01+
635-650	Heater working hours (MIC 1 - 16)	0 – 32000; [h]	1.01+
651-666	Freecooling Working Hours (MIC 1 - 16)	0 – 32000; [h]	1.01+
667-682	Conditioner working hours warning level (MIC 1 - 16)	0 – 32000; [h]	1.01+
683-698	Compressor working hours warning level (MIC 1 - 16)	0 – 32000; [h]	1.01+
699-714	Humidifier working hours warning level (MIC 1 - 16)	0 – 32000; [h]	1.01+
715-730	Heater working hours warning level (MIC 1 – 16)	0 – 32000; [h]	1.01+
731-746	Number of fan starts	0 – 32000;	1.01+
747-762	Number of compressor starts	0 – 32000;	1.01+

### Status-Report-Acknowledge (Holding Register #1):

Read the document 'Hirolink for Modbus V X.XX - General Documentation' (X.XX is a placeholder for the current version of the Hirolink) for a description on how to use this data-point.

### HM Alarm Status (Holding Register #3) and Single Alarm-Status (Holding Registers #27 - #42):

This item holds a value, which represents the current alarm-state of the Hiromatic and the single Microfaces.

It can be written to in order to perform either a 'Alarm Acknowledge'- or a 'Alarm Reset'-command on the Hiromatic or a single Microface:

#### 2 .. Alarm Reset:

This command will reset all alarms, warnings and messages currently present on the Hiromatic or Microface. As a consequence alarms, warnings and messages that are inactive will disappear, will active alarms, warnings and messages will be reported again.

#### 4 .. Alarm Acknowledge:

This command will acknowledge all alarms, warnings and messages present on the Hiromatic or Microface. As a consequence alarms, warnings and messages that were in an unacknowledged state will be acknowledged after the command.

When read, the value corresponds to the following states:

0 .. No alarm present

1 .. Message acknowledged (inactive)

3 .. Message acknowledged (active)

5 .. Message not acknowledged (inactive)

7 .. Message not acknowledged (active)

9 .. Warning acknowledged (inactive)

11.. Warning acknowledged (active)

13.. Warning not acknowledged (inactive)

15.. Warning not acknowledged (active)

17.. Alarm acknowledged (inactive)

19.. Alarm acknowledged (active)

21...Alarm not acknowledged (inactive)

23.. Alarm not acknowledged (active)

25.. Alarm and warning acknowledged (inactive)

27.. Alarm and warning acknowledged (active)

- 29.. Alarm and warning not acknowledged (inactive)
- 31.. Alarm and warning not acknowledged (active)

The terms 'acknowledged' and 'not acknowledged' define, if the reset-push-button on the Hiromatic has been pressed once in order to silence the buzzer or if the command 'Alarm Acknowledge' has been performed.

The terms 'active' and 'inactive' define, if the alarm, warning or message is still active, which means that after performing a alarm-reset (either by sending the appropriate command via the Modbus-network or by pressing the reset-push-button on the Hiromatic a second time) the alarm or warning will be reported again.

**NOTE:**

Although you can read the alarm-state of the whole system, it is not possible to issue a 'Alarm Acknowledge'- or 'Alarm Reset'-command for the whole system. Instead you have to issue these commands for each Microface separately.

### 3.4 Input-Register

Register #	Usage	Range; Unit	SW-Version
1	Event-ID	ID identifying the event	1.01+
2	Controller-ID	Controller-ID, where the event occurred	1.01+
3	Minute	Minute, when event occurred	1.01+
4	Hour	Hour, when event occurred	1.01+
5	Date	Date, when event occurred	1.01+
6	Event-type	0 -> message, 1 -> warning, 2 -> alarm, 3 and 4 -> reset	1.01+
7	System status	See explanation below	1.01+
8	System alarm	See explanation below	1.01+
9-24	Single status (MIC 1 - 16)	See explanation below	1.01+
25-40	Extended single status (MIC 1 - 16)	See explanation below	1.01+
41-56	Single alarm status (MIC 1 - 16)	See explanation below	1.01+
57	Shared room temperature (average of all room-temperature-sensors) (MIC 1 - 16)	-250 - 1000; [1/10 °C]	1.01+
58-72	Not used		1.01+
73	Shared room humidity (average of all room-humidity-sensors) (MIC 1 - 16)	0 – 100; [%RH]	1.01+
74-88	Not used		1.01+
89	Shared ambient temperature (average of all room-temperature-sensors) (MIC 1 - 16)	-250 - 1000; [1/10 °C]	1.01+
90-104	Not used		1.01+
105-120	Actual Temperature Setpoint (MIC 1 - 16)	50 - 400; [1/10 °C]	1.01+
121-136	Freecooling Status (MIC 1 - 16)	0 -> FC Off; 1 -> FC Start; 2 -> FC On; 3 -> No FC Mode	1.01+
137-152	Local temperature (MIC 1 - 16)	-250 - 1000; [1/10 °C]	1.01+
153-168	Ambient temperature (MIC 1 - 16)	-250 - 1000; [1/10 °C]	1.01+
169-184	PTC temperature (MIC 1 - 16)	-250 - 1150; [1/10 °C]	1.01+
185-200	Supply air temperature (MIC 1 - 16)	-250 - 1000; [1/10 °C]	1.01+
201-216	Return air temperature (MIC 1 - 16)	-250 - 1000; [1/10 °C]	1.01+
217-232	Local expansion temperature (MIC 1 - 16)	-250 - 1000; [1/10 °C]	1.01+
233-248	Hirosenor 1 temperature 1 (MIC 1 - 16)	-250 - 1000; [1/10 °C]	1.01+
249-264	Hirosenor 1 temperature 2 (MIC 1 - 16)	-250 - 1000; [1/10 °C]	1.01+
265-280	Hirosenor 2 temperature 1 (MIC 1 - 16)	-250 - 1000; [1/10 °C]	1.01+
281-296	Hirosenor 2 temperature 2 (MIC 1 - 16)	-250 - 1000; [1/10 °C]	1.01+
297-312	Room Temperature (MIC 1 - 16)	-250 - 1000; [1/10 °C]	1.01+
313-328	Room Humidity (MIC 1 - 16)	0 - 1000; [1/10 %RH]	1.01+
329-344	EEAP Temperature (MIC 1 - 16)	-250 - 1000; [1/10 °C]	1.01+
345-360	EEAP Humidity (MIC 1 - 16)	0 - 1000; [1/10 %RH]	1.01+

361-376	Low pressure sensor value (MIC 1 - 16)	-100 - 500; [1/10 bar]	1.01+
377-392	High pressure sensor value (MIC 1 - 16)	100 - 500; [1/10 bar]	1.01+
393-408	User switch input status (MIC 1 - 16)	0 -> Off; 1 -> On	1.01+
409-424	Fan failure switch input status (MIC 1 - 16)	0 -> Off; 1 -> On	1.01+
425-440	Heater safety thermostat / Humidifier failure switch input status (MIC 1 - 16)	0 -> Off; 1 -> On	1.01+
441-456	Condenser failure switch input status	0 -> Off; 1 -> On	1.01+
457-472	Low pressure switch input status	0 -> Off; 1 -> On	1.01+
473-488	High pressure switch input status	0 -> Off; 1 -> On	1.01+
489-504	Compressor motor protection switch input status	0 -> Off; 1 -> On	1.01+
505-520	Compressor remote switch input status	0 -> Off; 1 -> On	1.01+
521-536	Compressor contactor msg. switch input status	0 -> Off; 1 -> On	1.01+
537-552	External control switch input status	0 -> Off; 1 -> On	1.01+
553-568	Clogged return air filter switch input status	0 -> Off; 1 -> On	1.01+
569-584	Clogged fresh air filter switch input status	0 -> Off; 1 -> On	1.01+
585-600	Fan status (MIC 1 - 16)	0 -> Off, 1 -> On	1.01+
601-616	Compressor status (MIC 1 - 16)	0 -> Off, 1 -> On	1.01+
617-632	Electrical heater 1 status (MIC 1 - 16)	0 -> Off, 1 -> On	1.01+
633-648	Electrical heater 2 status (MIC 1 - 16)	0 -> Off, 1 -> On	1.01+
649-664	Humidifier status (MIC 1 - 16)	0 -> Off, 1 -> On	1.01+
665-680	Chilled water ramp (MIC 1 - 16)	0 - 100; [%]	1.01+
681-696	Hot water ramp (MIC 1 - 16)	0 - 100; [%]	1.01+
697-712	Humidifier ramp (MIC 1 - 16)	0 - 100; [%]	1.01+
713-728	Analog output 1 (MIC 1 - 16)	0 - 100; [%]	1.01+
729-744	Analog output 2 (MIC 1 - 16)	0 - 100; [%]	1.01+
745-760	Analog alarm-board output	0 - 100; [%]	1.01+
761-776	3 point valve position	0 - 100; [%]	1.01+

### Status-Report-Block (Input Register #1 - #6):

Read the document 'Hirolink for Modbus V X.XX - General Documentation' (X.XX is a placeholder for the current version of the Hirolink) for a description on how to use these data-points.

### System-Alarm (Input Register #8):

This item holds a value, which represents the current alarm-state of the whole system. This alarm-state is calculated from the single alarm-states of each Microface and holds the highest of those alarm-states. The single alarm-states can be read using the appropriate Holding Registers.

The values correspond to the following states:

- 0 .. No alarm present
- 1 .. Message acknowledged (inactive)
- 3 .. Message acknowledged (active)
- 5 .. Message not acknowledged (inactive)
- 7 .. Message not acknowledged (active)
  
- 9 .. Warning acknowledged (inactive)
- 11 .. Warning acknowledged (active)
- 13 .. Warning not acknowledged (inactive)
- 15 .. Warning not acknowledged (active)
  
- 17 .. Alarm acknowledged (inactive)
- 19 .. Alarm acknowledged (active)
- 21 .. Alarm not acknowledged (inactive)
- 23 .. Alarm not acknowledged (active)
  
- 25 .. Alarm and warning acknowledged (inactive)
- 27 .. Alarm and warning acknowledged (active)
- 29 .. Alarm and warning not acknowledged (inactive)
- 31 .. Alarm and warning not acknowledged (active)



The terms 'acknowledged' and 'not acknowledged' define, if the reset-push-button on the Hiromatic has been pressed once in order to silence the buzzer or if the command 'Alarm Acknowledge' has been performed.

The terms 'active' and 'inactive' define, if the alarm, warning or message is still active, which means that after performing a alarm-reset (either by sending the appropriate command via the Modbus-network or by pressing the reset-push-button on the Hiromatic a second time) the alarm or warning will be reported again.

### System-Status (Input Register #7) and Single Status (Input Registers #9 - #24):

This item holds a value, which represents the current system-state of the whole system and of the single Microfaces. The values correspond to the following states:

- 0 .. Alarm Off
- 1 .. Manual
- 2 .. Local Off
- 3 .. System Off
- 4 .. Standby Alarm
- 5 .. Standby
- 6 .. Sleep / Off
- 7 .. System On
- 8 .. Warning On
- 9 .. Alarm On
- 10 .. Sleep

### Extended Single Status (Input Registers #25 - #40):

Description missing !

### Single Alarm Status (Input Register #41 - #56):

This item holds a value, which represents the current alarm-state of the whole system. This alarm-state is calculated from the single alarm-states of each Microface and holds the highest of those alarm-states. The single alarm-states can also be read using the appropriate Holding Registers.

The values correspond to the following states:

- 0 .. No alarm present
- 1 .. Message acknowledged (inactive)
- 3 .. Message acknowledged (active)
- 5 .. Message not acknowledged (inactive)
- 7 .. Message not acknowledged (active)
  
- 9 .. Warning acknowledged (inactive)
- 11 .. Warning acknowledged (active)
- 13 .. Warning not acknowledged (inactive)
- 15 .. Warning not acknowledged (active)
  
- 17 .. Alarm acknowledged (inactive)
- 19 .. Alarm acknowledged (active)
- 21 .. Alarm not acknowledged (inactive)
- 23 .. Alarm not acknowledged (active)
  
- 25 .. Alarm and warning acknowledged (inactive)
- 27 .. Alarm and warning acknowledged (active)
- 29 .. Alarm and warning not acknowledged (inactive)
- 31 .. Alarm and warning not acknowledged (active)

The terms 'acknowledged' and 'not acknowledged' define, if the reset-push-button on the Hiromatic has been pressed once in order to silence the buzzer or if the command 'Alarm Acknowledge' has been performed.

The terms 'active' and 'inactive' define, if the alarm, warning or message is still active, which means that after performing a alarm-reset (either by sending the appropriate command via the Modbus-network or by pressing the reset-push-button on the Hiromatic a second time) the alarm or warning will be reported again.

### 3.5 Events

#### **IMPORTANT:**

Read the document 'Hirolink for Modbus V X.XX - General Documentation' (X.XX is a placeholder for the current version of the Hirolink) for a detailed description on how to use these data-points.

In the following list you can see all Events and Event-IDs available for Telecom Italia-units:

Event-ID	Event-Description	Event-Type	SW-Version
0	GENERAL ALARM	Reset	1.01+
1	COMPRESSOR 1 HIGH PRESSURE	Alarm	1.01+
2	COMPRESSOR 1 LOW PRESSURE	Alarm	1.01+
3	HIGH CHILLED WATER TEMPERATURE	Warning	1.01+
4	LOW CHILLED WATER FLOW	Warning	1.01+
5	ELECTRICAL HEATERS OVERHEATED	Warning	1.01+
6	FAN FAILURE	Warning	1.01+
7	FAN FAILURE	Alarm	1.01+
8	CLOGGED FILTERS	Warning	1.01+
9	WATER LEAKAGE DETECTED	Warning	1.01+
10	WATER LEAKAGE DETECTED	Alarm	1.01+
11	USER INPUT TRIGGERED	Warning	1.01+
12	USER INPUT TRIGGERED	Alarm	1.01+
13	EXTERNAL HUMIDIFIER FAILURE	Warning	1.01+
14	HUMIDIFIER HIGH CURRENT	Warning	1.01+
15	HUMIDIFIER FAILURE	Warning	1.01+
16	HUMIDIFIER FAILURE	Warning	1.01+
17	HUMIDIFIER CYLINDER WARNING	Warning	1.01+
18	HIGH ROOM TEMPERATURE	Warning	1.01+
19	LOW ROOM TEMPERATURE	Warning	1.01+
20	HIGH ROOM HUMIDITY	Warning	1.01+
21	LOW ROOM HUMIDITY	Warning	1.01+
22	HIGH ROOM TEMPERATURE (EEAP)	Warning	1.01+
23	LOW ROOM TEMPERATURE (EEAP)	Warning	1.01+
24	HIGH ROOM HUMIDITY (EEAP)	Warning	1.01+
25	LOW ROOM HUMIDITY (EEAP)	Warning	1.01+
26	CONDITIONER WORKING HOURS EXCEEDED	Warning	1.01+
27	COMPRESSOR 1 WORKING HOURS EXCEEDED	Warning	1.01+
28	HUMIDIFIER WORKING HOURS EXCEEDED	Warning	1.01+
29	PTC SENSOR FAILURE	Warning	1.01+
30	ROOM SENSOR FAILURE	Warning	1.01+
31	ROOM SENSOR FAILURE	Alarm	1.01+
32	EEAP SENSOR FAILURE	Warning	1.01+
33	WATER PRESENCE SENSOR FAILURE	Warning	1.01+
34	NETWORK FAILURE	Warning	1.01+
35	OUT OF MEMORY	Warning	1.01+
36	UNIT ON	Message	1.01+
37	UNIT OFF	Message	1.01+
38	SLEEP MODE	Message	1.01+

39	STANDBY MODE	Message	1.01+
40	POWER ON	Message	1.01+
41	POWER OFF	Message	1.01+
42	UNIT 1 DISCONNECTED	Alarm	1.01+
43	UNIT 2 DISCONNECTED	Alarm	1.01+
44	UNIT 3 DISCONNECTED	Alarm	1.01+
45	UNIT 4 DISCONNECTED	Alarm	1.01+
46	UNIT 5 DISCONNECTED	Alarm	1.01+
47	UNIT 6 DISCONNECTED	Alarm	1.01+
48	UNIT 7 DISCONNECTED	Alarm	1.01+
49	UNIT 8 DISCONNECTED	Alarm	1.01+
50	UNIT 9 DISCONNECTED	Alarm	1.01+
51	UNIT 10 DISCONNECTED	Alarm	1.01+
52	UNIT 11 DISCONNECTED	Alarm	1.01+
53	UNIT 12 DISCONNECTED	Alarm	1.01+
54	UNIT 13 DISCONNECTED	Alarm	1.01+
55	UNIT 14 DISCONNECTED	Alarm	1.01+
56	UNIT 15 DISCONNECTED	Alarm	1.01+
57	UNIT 16 DISCONNECTED	Alarm	1.01+
58	COMPRESSOR 2 HIGH PRESSURE	Alarm	1.01+
59	COMPRESSOR 2 LOW PRESSURE	Alarm	1.01+
60	COMPRESSOR 2 WORKING HOURS EXCEEDED	Warning	1.01+
61	OUTDOOR TEMPERATURE SENSOR FAILURE	Warning	1.01+
62	GLYCOL TEMPERATURE SENSOR FAILURE	Warning	1.01+
63	FREECOOLING STOPPED FOR 1 HOUR	Message	1.01+

100	UNIT CONNECTED	Message	1.01+
101	UNIT NOT CONNECTED	Message	1.01+

## 4. Document-Changes

This appendix contains all changes that have been applied to this document up to the current version:

### 1. Changes from V 1.00 to V 1.01

- The Hirolink-version-number was updated from V 2.82 to V 2.83.
- The following Holding Registers were removed due to memory-space-limitations:

Holding registers #763-778: Firmware  
Holding registers #779-794: 3 point valve running time  
Holding registers #795-810: Minimum 3 point valve opening  
Holding registers #811-826: Heater output 1 selection  
Holding registers #827-842: Heater output 2 selection  
Holding registers #843-858: Heater steps  
Holding registers #859-874: Heater deadband  
Holding registers #875-890: Humidifier installed  
Holding registers #891-906: Controller type  
Holding registers #907-922: Analog output 2 selection

## Connectivity

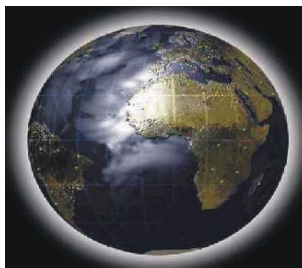

*the evolution*

## Hiolink for Modbus

(11a) Items for Telecom Italia (TIM) (Microface).doc

English

25/07/06 Release 1.00E

<b>1.</b>	<b>INTRODUCTION TELECOM ITALIA (TIM) (MICROFACE)</b> .....	<b>3</b>
<b>2.</b>	<b>COMPATIBILITY-LIST</b> .....	<b>3</b>
<b>3.</b>	<b>ITEMS FOR TELECOM ITALIA (TIM) (MICROFACE)</b> .....	<b>4</b>
3.1	COILS .....	4
3.2	INPUT-STATUS .....	4
3.3	HOLDING REGISTER .....	5
3.4	INPUT-REGISTER.....	7
3.5	EVENTS .....	10
<b>4.</b>	<b>DOCUMENT-CHANGES</b> .....	<b>11</b>

# 1. Introduction Telecom Italia (TIM) (Microface)

This document contains a description of all data-points that are available via the 'Hirolink for Modbus' from this type of air-conditioner.

## **IMPORTANT:**

It is vital to the correct integration of the Hirolink into a Modbus-network, that you have read and understood the topics described in the document 'Hirolink for Modbus V X.XX - General Documentation' (X.XX is a placeholder for the current version of the Hirolink). So, if you haven't read this document until now, read it first.

# 2. Compatibility-List

Before connecting a Hiromatic to the Modbus-Hirolink you must check, if the Hiromatic-software-version is compatible with this version of the Hirolink.

You can do this by checking the labels on the eproms, which are inserted into the Hiromatic and the Microface. The eprom inserted in the Hiromatic must be called TIG + Version-Number (e.g. TIG101) and the one inserted in the Microface must be called TIM + Version-Number (e.g. TIM101).

To make sure that the label on the eproms is correct, you should also check the version-information, that the Hiromatic displays shortly after start-up. This information should look similar to the following illustration:

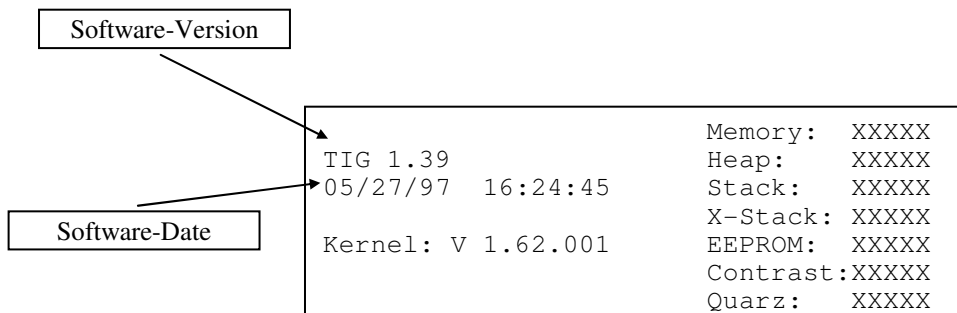

The important information in this window is only the software-version and the software-date (note that the date-format is mm/dd/yy). Make sure that the software-version installed in your installation matches one of the compatible versions listed below:

<b>Version</b>	<b>Date</b>
1.01	?

### 3. Items for Telecom Italia (TIM) (Microface)

According to the Modbus-protocol-specifications the values and parameters provided by the Hiromatic are represented in 4 groups:

- Coils: Used for changeable, digital values
- Inputs: Used for not changeable, digital values
- Holding Registers: Used for changeable, analog values
- Input Registers: Used for not changeable, analog values

This Hirolink can be compatible with more than one version of this Hiromatic-type and it is possible that there have been extensions in the number of available items from one version to the next.

Therefore the column 'SW-Version' contained in the following lists provides information about the availability of each item depending on the Hiromatic-software-version. For example a entry like '1.15+' means, that this item is available from Hiromatics with software-version 1.15 and higher.

#### **IMPORTANT:**

The available data-points shown in the following chapters are numbered starting from 1, according to the Modbus-Protocol-Specification. Still some BMS start numbering the data-points from 0. So, in case that the BMS you are using starts numbering from 0, you have to decrease the listed numbers by 1.

#### **3.1 Coils**

Not used on this Hiromatic-type.

#### **3.2 Input-Status**

Not used on this Hiromatic-type.

### 3.3 Holding Register

Register #	Usage	Range; Unit	SW-Version
1	Status-Report-acknowledge	See explanation below	1.01+
2	System on/off	0 -> System Off; 1 -> System On	1.01+
3	Alarm-status	See explanation below	1.01+
4	Number of units	1 - 16;	1.01+
5	Seconds of real time clock	0 - 59; [s]	1.01+
6	Minutes of real time clock	0 - 59; [min]	1.01+
7	Hours of real time clock	0 - 23; [h]	1.01+
8	Day of real time clock	1 - 31;	1.01+
9	Month of real time clock	1 - 12;	1.01+
10	Year of real time clock	0 - 99;	1.01+
11	NOT USED		
12	Room humidity setpoint	19 -> No; 20 - 80; [%RH]	1.01+
13	Supply air setpoint	5 - 25; [°C]	1.01+
14	Condenser setpoint		1.01+
15	NOT USED		
16	Humidity proportional band	5 - 20; [%RH]	1.01+
17	Condenser proportional band		1.01+
18	NOT USED		
19	Humidity integral factor	4 -> No, 5 - 15; [min]	1.01+
20	Condenser minimum speed		1.01+
21	Freecooling difference between room and ambient temperature	0 -> No, 1 -> EFC, 1 - 25; [K]	1.01+
22	NOT USED		
23	NOT USED		
24	NOT USED		
25	Auto-restart time		1.01+
26	Hirromatic on/off enabled	0 -> No, 1 -> Yes	1.01+
27	Number of Standby Units	0 - 16	1.01+
28	Rotation enabled	0 -> No, 1 -> Daily, 2 -> MO 3 -> TU, 4 -> WE, 5 -> TH 6 -> FR, 7 -> SA, 8 -> SU	1.01+
29	Rotation hour	0 - 23; [h]	1.01+
30	Rotation minute	0 - 59; [min]	1.01+
31	Perform rotation	See explanation below	1.01+
32	Low temperature warning	0 -> No, 1 - 99; [°C]	1.01+
33	High temperature warning	0 -> No, 1 - 99; [°C]	1.01+
34	Low humidity warning	0 -> No, 1 - 99; [%RH]	1.01+
35	High humidity warning	0 -> No, 1 - 99; [%RH]	1.01+
36	Low temperature alarm	0 -> No, 1 - 99; [°C]	1.01+
37	High temperature alarm	0 -> No, 1 - 99; [°C]	1.01+
38	NOT USED		
39	NOT USED		
40	Low Pressure Delay Time	0 - 5; [min]	1.01+
41	User input selection	0 - 3;	1.01+
42	Compressor high pressure warning level	100 - 300; [1/10 bar]	1.01+
43	Fan failure warning/alarm	0 -> Warning, 1 -> Alarm	1.01+
44	Liquistat warning/alarm	0 -> No, 1 -> Warning, 2 -> Alarm	1.01+
45	Conditioner working hours	0 - 32000; [h]	1.01+
46	Compressor working hours	0 - 32000; [h]	1.01+
47	Humidifier working hours	0 - 32000; [h]	1.01+
48	Heater working hours	0 - 32000; [h]	1.01+
49	Freecooling Working Hours	0 - 32000; [h]	1.01+
50	Conditioner working hours warning level	0 - 32000; [h]	1.01+



51	Compressor working hours warning level	0 – 32000; [h]	1.01+
52	Humidifier working hours warning level	0 – 32000; [h]	1.01+
53	Heater working hours warning level (MIC 1 – 16)	0 – 32000; [h]	1.01+
54	Number of fan starts	0 – 32000;	1.01+
55	Number of compressor starts	0 – 32000;	1.01+

### Status-Report-Acknowledge (Holding Register #1):

Read the document 'Hirolink for Modbus V X.XX - General Documentation' (X.XX is a placeholder for the current version of the Hirolink) for a description on how to use this data-point.

### HM Alarm Status (Holding Register #3) and Single Alarm-Status (Holding Registers #27 - #42):

This item holds a value, which represents the current alarm-state of the Hiromatic and the single Microfaces.

It can be written to in order to perform either a 'Alarm Acknowledge'- or a 'Alarm Reset'-command on the Hiromatic or a single Microface:

#### 2 .. Alarm Reset:

This command will reset all alarms, warnings and messages currently present on the Hiromatic or Microface. As a consequence alarms, warnings and messages that are inactive will disappear, will active alarms, warnings and messages will be reported again.

#### 4 .. Alarm Acknowledge:

This command will acknowledge all alarms, warnings and messages present on the Hiromatic or Microface. As a consequence alarms, warnings and messages that were in an unacknowledged state will be acknowledged after the command.

When read, the value corresponds to the following states:

0 .. No alarm present

1 .. Message acknowledged (inactive)

3 .. Message acknowledged (active)

5 .. Message not acknowledged (inactive)

7 .. Message not acknowledged (active)

9 .. Warning acknowledged (inactive)

11.. Warning acknowledged (active)

13.. Warning not acknowledged (inactive)

15.. Warning not acknowledged (active)

17.. Alarm acknowledged (inactive)

19.. Alarm acknowledged (active)

21...Alarm not acknowledged (inactive)

23.. Alarm not acknowledged (active)

25.. Alarm and warning acknowledged (inactive)

27.. Alarm and warning acknowledged (active)

29.. Alarm and warning not acknowledged (inactive)

31.. Alarm and warning not acknowledged (active)

The terms 'acknowledged' and 'not acknowledged' define, if the reset-push-button on the Hiromatic has been pressed once in order to silence the buzzer or if the command 'Alarm Acknowledge' has been performed.

The terms 'active' and 'inactive' define, if the alarm, warning or message is still active, which means that after performing a alarm-reset (either by sending the appropriate command via the Modbus-network or by pressing the reset-push-button on the Hiromatic a second time) the alarm or warning will be reported again.

**NOTE:**

Although you can read the alarm-state of the whole system, it is not possible to issue a 'Alarm Acknowledge'- or 'Alarm Reset'-command for the whole system. Instead you have to issue these commands for each Microface separately.

**3.4 Input-Register**

Register #	Usage	Range; Unit	SW-Version
1	Event-ID	ID identifying the event	1.01+
2	Controller-ID	Controller-ID, where the event occurred	1.01+
3	Minute	Minute, when event occurred	1.01+
4	Hour	Hour, when event occurred	1.01+
5	Date	Date, when event occurred	1.01+
6	Event-type	0 -> message, 1 -> alarm 2 -> warning, 3 and 4 -> reset	1.01+
7	Status	See explanation below	1.01+
8	Extended status	See explanation below	1.01+
9	Alarm status	See explanation below	1.01+
10	Shared room temperature (average of all room-temperature-sensors)	-250 - 1000; [1/10 °C]	1.01+
11	Shared room humidity (average of all room-humidity-sensors)	0 – 100; [%RH]	1.01+
12	Shared ambient temperature (average of all room-temperature-sensors)	-250 - 1000; [1/10 °C]	1.01+
13	NOT USED		
14	Freecooling Status	0 -> FC Off; 1 -> FC Start; 2 -> FC On; 3 -> No FC Mode	1.01+
15	Local temperature	-250 - 1000; [1/10 °C]	1.01+
16	Ambient temperature	-250 - 1000; [1/10 °C]	1.01+
17	PTC temperature	-250 - 1150; [1/10 °C]	1.01+
18	Supply air temperature	-250 - 1000; [1/10 °C]	1.01+
19	Return air temperature	-250 - 1000; [1/10 °C]	1.01+
20	Local expansion temperature	-250 - 1000; [1/10 °C]	1.01+
21	Hirosenor 1 temperature 1	-250 - 1000; [1/10 °C]	1.01+
22	Hirosenor 1 temperature 2	-250 - 1000; [1/10 °C]	1.01+
23	Hirosenor 2 temperature 1	-250 - 1000; [1/10 °C]	1.01+
24	Hirosenor 2 temperature 2	-250 - 1000; [1/10 °C]	1.01+
25	Room Temperature	-250 - 1000; [1/10 °C]	1.01+
26	Room Humidity	0 - 1000; [1/10 %RH]	1.01+
27	EEAP Temperature	-250 - 1000; [1/10 °C]	1.01+
28	EEAP Humidity	0 - 1000; [1/10 %RH]	1.01+
29	Low pressure sensor value	-100 - 500; [1/10 bar]	1.01+
30	High pressure sensor value	100 - 500; [1/10 bar]	1.01+
31	User switch input status	0 -> Off; 1 -> On	1.01+
32	Fan failure switch input status	0 -> Off; 1 -> On	1.01+
33	Heater safety thermostat / Humidifier failure switch input status	0 -> Off; 1 -> On	1.01+
34	Condenser failure switch input status	0 -> Off; 1 -> On	1.01+
35	Low pressure switch input status	0 -> Off; 1 -> On	1.01+
36	High pressure switch input status	0 -> Off; 1 -> On	1.01+
37	Compressor motor protection switch input status	0 -> Off; 1 -> On	1.01+

38	Compressor remote switch input status	0 -> Off; 1 -> On	1.01+
39	Compressor contactor msg. switch input status	0 -> Off; 1 -> On	1.01+
40	External control switch input status	0 -> Off; 1 -> On	1.01+
41	Clogged return air filter switch input status	0 -> Off; 1 -> On	1.01+
42	Clogged fresh air filter switch input status	0 -> Off; 1 -> On	1.01+
43	Fan status	0 -> Off; 1 -> On	1.01+
44	Compressor status (MIC 1 – 16)	0 -> Off; 1 -> On	1.01+
45	Electrical heater 1 status	0 -> Off; 1 -> On	1.01+
46	Electrical heater 2 status	0 -> Off; 1 -> On	1.01+
47	Humidifier status	0 -> Off; 1 -> On	1.01+
48	Chilled water ramp	0 – 100; [%]	1.01+
49	Hot water ramp	0 – 100; [%]	1.01+
50	Humidifier ramp	0 – 100; [%]	1.01+
51	Analog output 1	0 – 100; [%]	1.01+
52	Analog output 2	0 – 100; [%]	1.01+
53	Analog alarm-board output	0 – 100; [%]	1.01+
54	3 point valve position	0 – 100; [%]	1.01+

### Status-Report-Block (Input Register #1 - #6):

Read the document 'Hirolink for Modbus V X.XX - General Documentation' (X.XX is a placeholder for the current version of the Hirolink) for a description on how to use these data-points.

### System-Alarm (Input Register #8):

This item holds a value, which represents the current alarm-state of the whole system. This alarm-state is calculated from the single alarm-states of each Microface and holds the highest of those alarm-states. The single alarm-states can be read using the appropriate Holding Registers.

The values correspond to the following states:

- 0 .. No alarm present
- 1 .. Message acknowledged (inactive)
- 3 .. Message acknowledged (active)
- 5 .. Message not acknowledged (inactive)
- 7 .. Message not acknowledged (active)
  
- 9 .. Warning acknowledged (inactive)
- 11 .. Warning acknowledged (active)
- 13 .. Warning not acknowledged (inactive)
- 15 .. Warning not acknowledged (active)
  
- 17 .. Alarm acknowledged (inactive)
- 19 .. Alarm acknowledged (active)
- 21 .. Alarm not acknowledged (inactive)
- 23 .. Alarm not acknowledged (active)
  
- 25 .. Alarm and warning acknowledged (inactive)
- 27 .. Alarm and warning acknowledged (active)
- 29 .. Alarm and warning not acknowledged (inactive)
- 31 .. Alarm and warning not acknowledged (active)

The terms 'acknowledged' and 'not acknowledged' define, if the reset-push-button on the Hiromatic has been pressed once in order to silence the buzzer or if the command 'Alarm Acknowledge' has been performed.

The terms 'active' and 'inactive' define, if the alarm, warning or message is still active, which means that after performing a alarm-reset (either by sending the appropriate command via the Modbus-network or by pressing the reset-push-button on the Hiromatic a second time) the alarm or warning will be reported again.

### System-Status (Input Register #7) and Single Status (Input Registers #9 - #24):

This item holds a value, which represents the current system-state of the whole system and of the single Microfaces. The values correspond to the following states:

- 0 .. Alarm Off
- 1 .. Manual
- 2 .. Local Off
- 3 .. System Off
- 4 .. Standby Alarm
- 5 .. Standby
- 6 .. Sleep / Off
- 7 .. System On
- 8 .. Warning On
- 9 .. Alarm On
- 10 .. Sleep

Extended Single Status (Input Registers #25 - #40):

Description missing !

Single Alarm Status (Input Register #41 - #56):

This item holds a value, which represents the current alarm-state of the whole system. This alarm-state is calculated from the single alarm-states of each Microface and holds the highest of those alarm-states. The single alarm-states can also be read using the appropriate Holding Registers.

The values correspond to the following states:

- 0 .. No alarm present
- 1 .. Message acknowledged (inactive)
- 3 .. Message acknowledged (active)
- 5 .. Message not acknowledged (inactive)
- 7 .. Message not acknowledged (active)
  
- 9 .. Warning acknowledged (inactive)
- 11 .. Warning acknowledged (active)
- 13 .. Warning not acknowledged (inactive)
- 15 .. Warning not acknowledged (active)
  
- 17 .. Alarm acknowledged (inactive)
- 19 .. Alarm acknowledged (active)
- 21 .. Alarm not acknowledged (inactive)
- 23 .. Alarm not acknowledged (active)
  
- 25 .. Alarm and warning acknowledged (inactive)
- 27 .. Alarm and warning acknowledged (active)
- 29 .. Alarm and warning not acknowledged (inactive)
- 31 .. Alarm and warning not acknowledged (active)

The terms 'acknowledged' and 'not acknowledged' define, if the reset-push-button on the Hiromatic has been pressed once in order to silence the buzzer or if the command 'Alarm Acknowledge' has been performed.

The terms 'active' and 'inactive' define, if the alarm, warning or message is still active, which means that after performing a alarm-reset (either by sending the appropriate command via the Modbus-network or by pressing the reset-push-button on the Hiromatic a second time) the alarm or warning will be reported again.

### 3.5 Events

#### **IMPORTANT:**

Read the document 'Hirolink for Modbus V X.XX - General Documentation' (X.XX is a placeholder for the current version of the Hirolink) for a detailed description on how to use these data-points.

In the following list you can see all Events and Event-IDs available for Telecom Italia-units:

Event-ID	Event-Description	Event-Type	SW-Version
0	GENERAL ALARM	Reset	1.01+
1	COMPRESSOR 1 HIGH PRESSURE	Alarm	1.01+
2	COMPRESSOR 1 LOW PRESSURE	Alarm	1.01+
3	HIGH CHILLED WATER TEMPERATURE	Warning	1.01+
4	LOW CHILLED WATER FLOW	Warning	1.01+
5	ELECTRICAL HEATERS OVERHEATED	Warning	1.01+
6	FAN FAILURE	Warning	1.01+
7	FAN FAILURE	Alarm	1.01+
8	CLOGGED FILTERS	Warning	1.01+
9	WATER LEAKAGE DETECTED	Warning	1.01+
10	WATER LEAKAGE DETECTED	Alarm	1.01+
11	USER INPUT TRIGGERED	Warning	1.01+
12	USER INPUT TRIGGERED	Alarm	1.01+
13	EXTERNAL HUMIDIFIER FAILURE	Warning	1.01+
14	HUMIDIFIER HIGH CURRENT	Warning	1.01+
15	HUMIDIFIER FAILURE	Warning	1.01+
16	HUMIDIFIER FAILURE	Warning	1.01+
17	HUMIDIFIER CYLINDER WARNING	Warning	1.01+
18	HIGH ROOM TEMPERATURE	Warning	1.01+
19	LOW ROOM TEMPERATURE	Warning	1.01+
20	HIGH ROOM HUMIDITY	Warning	1.01+
21	LOW ROOM HUMIDITY	Warning	1.01+
22	HIGH ROOM TEMPERATURE (EEAP)	Warning	1.01+
23	LOW ROOM TEMPERATURE (EEAP)	Warning	1.01+
24	HIGH ROOM HUMIDITY (EEAP)	Warning	1.01+
25	LOW ROOM HUMIDITY (EEAP)	Warning	1.01+
26	CONDITIONER WORKING HOURS EXCEEDED	Warning	1.01+
27	COMPRESSOR 1 WORKING HOURS EXCEEDED	Warning	1.01+
28	HUMIDIFIER WORKING HOURS EXCEEDED	Warning	1.01+
29	PTC SENSOR FAILURE	Warning	1.01+
30	ROOM SENSOR FAILURE	Warning	1.01+
31	ROOM SENSOR FAILURE	Alarm	1.01+
32	EEAP SENSOR FAILURE	Warning	1.01+
33	WATER PRESENCE SENSOR FAILURE	Warning	1.01+
34	NETWORK FAILURE	Warning	1.01+
35	OUT OF MEMORY	Warning	1.01+
36	UNIT ON	Message	1.01+
37	UNIT OFF	Message	1.01+
38	SLEEP MODE	Message	1.01+
39	STANDBY MODE	Message	1.01+
40	POWER ON	Message	1.01+
41	POWER OFF	Message	1.01+
42-57	NOT USED		
58	COMPRESSOR 2 HIGH PRESSURE	Alarm	1.01+
59	COMPRESSOR 2 LOW PRESSURE	Alarm	1.01+
60	COMPRESSOR 2 WORKING HOURS EXCEEDED	Warning	1.01+
61	OUTDOOR TEMPERATURE SENSOR FAILURE	Warning	1.01+

62	GLYCOL TEMPERATURE SENSOR FAILURE	Warning	1.01+
63	FREECOOLING STOPPED FOR 1 HOUR	Message	1.01+
64	NOT USED		
65	SMOKE ALARM	Warning	1.01+
66	NO POWER (USER INPUT)	Message	1.01+
67	POWER ON (USER INPUT)	Message	1.01+
68	INTERNAL CONTROL	Message	1.01+
69	EXTERNAL CONTROL	Message	1.01+
70	NO CONNECTION TO UNIT 1	Warning	1.01+
71	COMPRESSOR THERMAL PROTECTION	Alarm	1.01+
72	CONDENSER FAILURE	Alarm	1.01+
73	FIRE ALARM	Alarm	1.01+
74	COMPRESSOR HIGH PRESSURE WARNING	Message	1.01+
75	COMPRESSOR HIGH PRESSURE WARNING OK	Message	1.01+
76	NOT USED		
77	HEATERS / FC DAMPER FAILURE	Warning	1.01+

100	UNIT CONNECTED	Message	1.01+
101	UNIT NOT CONNECTED	Message	1.01+

#### 4. Document-Changes

## Connectivity

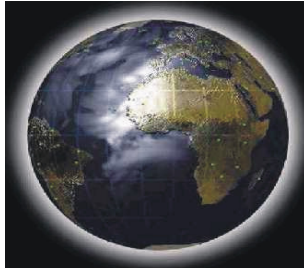

*the evolution*

## Hirolink for Modbus

(12) Items for New Hichill (CHG) (Microface).doc

English

04/11/03 Release 1.01E

<b>1.</b>	<b>INTRODUCTION NEW HICHILL (CHG) (MACROFACE)</b> .....	<b>3</b>
<b>2.</b>	<b>COMPATIBILITY-LIST</b> .....	<b>3</b>
<b>3.</b>	<b>ITEMS FOR NEW HICHILL (CHG) (MACROFACE)</b> .....	<b>4</b>
3.1	COILS .....	4
3.2	INPUT-STATUS .....	4
3.3	HOLDING REGISTER .....	4
3.4	INPUT-REGISTER.....	7
3.5	EVENTS .....	9
3.5.1	<i>Event-Registers</i> .....	9
3.5.2	<i>Event-List</i> .....	10
<b>4.</b>	<b>DOCUMENT-CHANGES</b> .....	<b>11</b>



# 1. Introduction New Hichill (CHG) (Macroface)

This document contains a description of all data-points that are available via the 'Hirolink for Modbus' from this type of unit.

## **IMPORTANT:**

It is vital to the correct integration of the Hirolink into a Modbus-network that you have read and understood the topics described in the document 'Hirolink for Modbus V X.XX - General Documentation' (X.XX is a placeholder for the current version of the Hirolink). So, if you haven't read this document until now, read it first.

## 2. Compatibility-List

Before connecting a Hiromatic to the Modbus-Hirolink you must check if the Hiromatic-software-version is compatible with this version of the Hirolink.

You can do this by checking the labels on the eproms, which are inserted into the Hiromatic and the Microface. The eprom inserted in the Hiromatic must be called CHG + Version-Number (e.g. CHG102) and the one inserted in the Microface must be called CHM + Version-Number (e.g. CHM102).

To make sure that the label on the eproms is correct, you should also check the version-information that the Hiromatic displays shortly after start-up. This information should look similar to the following illustration:

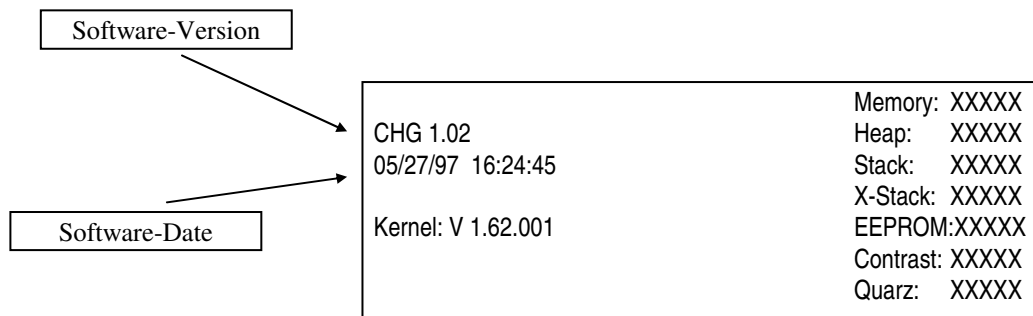

The important information in this window is only the software-version and the software-date (note that the date-format is mm/dd/yy). Make sure that the software-version installed in your installation matches one of the compatible versions listed below:

<b>Version</b>	<b>Date</b>
1.02	17.06.98
1.03	12.06.99

### 3. Items for New Hichill (CHG) (Macroface)

According to the Modbus-protocol-specifications the values and parameters provided by the Hiromatic are represented in 4 groups:

- Coils: Used for changeable, digital values
- Inputs: Used for not changeable, digital values
- Holding Registers: Used for changeable, analog values
- Input Registers: Used for not changeable, analog values

This Hirolink can be compatible with more than one version of this Hiromatic-type and it is possible that there have been extensions in the number of available items from one version to the next.

Therefore the column 'SW-Version' contained in the following lists provides information about the availability of each item depending on the Hiromatic-software-version. For example a entry like '1.02+' means, that this item is available from Hiromatics with software-version 1.02 and higher.

#### **IMPORTANT:**

The available data-points shown in the following chapters are numbered starting from 1, according to the Modbus-Protocol-Specification. Still some BMS start numbering the data-points from 0. So, in case that the BMS you are using starts numbering from 0, you have to decrease the listed numbers by 1.

#### **3.1 Coils**

Not used on this Hiromatic-type.

#### **3.2 Input-Status**

Not used on this Hiromatic-type.

#### **3.3 Holding Register**

Register #	Usage	Range; Unit	SW-Version
1	Status-Report-Acknowledge	See explanation below	1.02+
2	HM-System On/Off	0 -> Hiromatic System Off; 1 -> Hiromatic System On	1.02+
3	HM Alarm-Status	See explanation below	1.02+
4	Seconds from HM's real time clock	0-59; [s]	1.02+
5	Minutes from HM's real time clock	0-59; [min]	1.02+
6	Hours from HM's real time clock	0-23; [h]	1.02+
7	Day from HM's real time clock	1-31	1.02+
8	Month from HM's real time clock	1-12	1.02+
9	Year from HM's real time clock	0-99	1.02+
10-25	Single Unit System On/Off (MIC 1 - 16)	0 -> Single Unit System Off; 1 -> Single Unit System On	1.02+
26-41	Single Alarm-Status (MIC 1 - 16)	See explanation below	1.02+
42-57	Inlet Temperature Setpoint 1 (MIC 1 - 16)	-50 – 300; [1/10 °C]	1.02+
58-73	Inlet Temperature Setpoint 2 (MIC 1 - 16)	-6 -> No; -5 - 30; [°C]	1.02+
74-89	Inlet Temperature Setpoint (Timer Mode) (MIC 1 - 16)	4 -> No, 5 - 30; [°C]	1.02+
90-105	Outlet Temperature Low Limit (MIC 1 – 16)	-11 -> No; -10 - 30; [°C]	1.02+
106-121	Temperature Integration Factor (MIC 1 – 16)	4 -> No, 5 - 15; [min]	1.02+

122-137	Temperature Proportional Band (MIC 1 - 16)	10 – 100; [1/10 °C]	1.02+
138-153	High Inlet Water Temperature Warning (MIC 1 - 16)	0 -> No, 1 – 99; [°C]	1.02+
154-169	Low Inlet Water Temperature Warning (MIC 1 - 16)	0 -> No, 1 – 99; [°C]	1.02+
170-185	High Outlet Water Temperature Warning (MIC 1 - 16)	0 -> No, 1 – 99; [°C]	1.02+
186-201	Low Outlet Water Temperature Warning (MIC 1 - 16)	0 -> No, 1 – 99; [°C]	1.02+
202-217	High Inlet Water Temperature Alarm (MIC 1 - 16)	0 -> No, 1 – 99; [°C]	1.02+
218-233	Low Inlet Water Temperature Alarm (MIC 1 - 16)	0 -> No, 1 – 99; [°C]	1.02+
234-249	High Outlet Water Temperature Alarm (MIC 1 - 16)	0 -> No, 1 – 99; [°C]	1.02+
250-265	Low Outlet Water Temperature Alarm (MIC 1 - 16)	0 -> No, 1 – 99; [°C]	1.02+
266-281	Low Water Pressure Warning/Alarm at (MIC 1 - 16)	0 -> No, 1 - 10; [bar]	1.02+
282-297	Low Water Pressure Warning or Alarm (MIC 1 - 16)	0 -> Warning, 1 -> Alarm	1.02+
298-313	Compressor Low Pressure Delay (MIC 1 - 16)	0 - 5; [min]	1.02+
314-329	Compressor High Pressure Warning at (MIC 1 - 16)	10 – 250; [1/10 bar]	1.02+
330-345	Condenser Setpoint (MIC 1 - 16)	100 – 250; [1/10 bar]	1.02+
346-361	Condenser Control Hysteresis (MIC 1 - 16)	10 – 100; [1/10 bar]	1.02+
362-377	Freeze Warning at (MIC 1 - 16)	-250 - 100; [1/10 °C]	1.02+
378-393	Automatic Reset of Freeze Warning (MIC 1 - 16)	0 -> Automatic; 1 -> Manual	1.02+
394-409	Minimum Condenser Signal (MIC 1 – 16)	25 -50; [%]	1.02+
410-425	Maximum Condenser Signal (MIC 1 – 16)	50 –100; [%]	1.02+
426-441	User Input Selection (MIC 1 - 16)	See explanation below	1.02+
442-457	Refrigerant Type Unit Code (MIC 1 - 16)	Should be removed !!! 0 -> 2; 1 -> 4; 2 -> 7	1.02+
458-473	Autorestart Delay (MIC 1 - 16)	0 – 999; [s]	1.02+
474-489	Teamwork Enable (MIC 1 - 16)	0 -> No, 1 -> Yes	1.02+
490-505	Cascade Standby Units Enable (MIC 1 - 16)	0 -> No, 1 -> Yes	1.02+
506-521	Rotation Frequency (MIC 1 - 16)	See explanation below	1.02+
522-537	Microface Rotation Enable (MIC 1 - 16)	Should be removed !!!	1.02+
538-553	Rotation Hour (MIC 1 - 16)	0 – 23; [h]	1.02+
554-569	Rotation Minute (MIC 1 - 16)	0 – 59; [min]	1.02+
570-585	Seconds from MIC's real time clock (MIC 1 - 16)	0-59; [s]	1.02+
586-601	Minutes from MIC's real time clock (MIC 1 - 16)	0-59; [min]	1.02+
602-617	Hours from MIC's real time clock (MIC 1 - 16)	0-23; [h]	1.02+
618-633	Day from MIC's real time clock (MIC 1 - 16)	1-31	1.02+
634-649	Month from MIC's real time clock (MIC 1 - 16)	1-12	1.02+
650-665	Year from MIC's real time clock (MIC 1 - 16)	0-99	1.02+

### Status-Report-Acknowledge (Holding Register #1):

Read the document 'Hirolink for Modbus V X.XX - General Documentation' (X.XX is a placeholder for the current version of the Hirolink) for a description on how to use this data-point.

### HM Alarm-Status (Holding Registers #3) and Single Alarm Status (Holding Registers #26 - #41):

This item holds a value, which represents the current alarm-state of the Hiromatic or a single Microface.

It can be written to in order to perform either a 'Alarm Acknowledge'- or a 'Alarm Reset'-command on the Hiromatic or a single Microface:

#### 2 .. Alarm Reset:

This command will reset all alarms, warnings and messages currently present on a Microface. As a consequence alarms, warnings and messages that are inactive will disappear, will active alarms, warnings and messages will be reported again.

- 4 .. Alarm Acknowledge:  
This command will acknowledge all alarms, warnings and messages present on a Microface. As a consequence alarms, warnings and messages that were in an unacknowledged state will be acknowledged after the command.

When read, the value corresponds to the following states:

- 0 .. No alarm present
- 1 .. Message acknowledged (inactive)
- 3 .. Message acknowledged (active)
- 5 .. Message not acknowledged (inactive)
- 7 .. Message not acknowledged (active)
  
- 9 .. Warning acknowledged (inactive)
- 11.. Warning acknowledged (active)
- 13.. Warning not acknowledged (inactive)
- 15.. Warning not acknowledged (active)
  
- 17.. Alarm acknowledged (inactive)
- 19.. Alarm acknowledged (active)
- 21.. Alarm not acknowledged (inactive)
- 23.. Alarm not acknowledged (active)
  
- 25.. Alarm and warning acknowledged (inactive)
- 27.. Alarm and warning acknowledged (active)
- 29.. Alarm and warning not acknowledged (inactive)
- 31.. Alarm and warning not acknowledged (active)

The terms 'acknowledged' and 'not acknowledged' define, if the reset-push-button on the Hiromatic has been pressed once in order to silence the buzzer or if the command 'Alarm Acknowledge' has been performed.

The terms 'active' and 'inactive' define, if the alarm, warning or message is still active, which means that after performing a alarm-reset (either by sending the appropriate command via the Modbus-network or by pressing the reset-push-button on the Hiromatic a second time) the alarm or warning will be reported again.

**NOTE:**

Although you can read the alarm-state of the whole system, it is not possible to issue a 'Alarm Acknowledge'- or 'Alarm Reset'-command for the whole system. Instead you have to issue these commands for each Microface separately.

**User Input Selection (Holding Registers #426-#441):**

This value defines the functionality of the MIC's User Input according to the following list:

- 0 .. Warning
- 1 .. Alarm
- 2 .. Stop one compressor
- 3 .. Stop both compressors
- 4 .. Second setpoint
- 5 .. Shift setpoint
- 6 .. Water pressure sensor

**Rotation Frequency (Holding Registers #506-#521):**

This value defines the rotation-frequency of the Microfaces:

- 0 .. No
- 1 .. Daily
- 2 .. Every Monday
- 3 .. Every Tuesday
- 4 .. Every Wednesday
- 5 .. Every Thursday
- 6 .. Every Friday
- 7 .. Every Saturday
- 8 .. Every Sunday

### 3.4 Input-Register

Register #	Usage	Range; Unit	SW-Version
1	Event-ID	ID identifying the event	1.02+
2	Controller-ID	Controller-ID, where the event occurred	1.02+
3	Minute	Minute, when event occurred	1.02+
4	Hour	Hour, when event occurred	1.02+
5	Date	Date, when event occurred	1.02+
6	Event-Type	0 -> message, 1 -> warning, 2 -> alarm, 3 and 4 -> reset	1.02+
7	System Alarm	See explanation below	1.02+
8	System Status	See explanation below	1.02+
9-24	Single Alarm Status (MIC 1 – 16)	See explanation below	1.02+
25-40	Single Unit Status (MIC 1 – 16)	See explanation below	1.02+
41	Shared PTC Inlet Temperature	[1/10 °C]	1.02+
42-56	Not used		
57	Shared PTC Outlet Temperature	[1/10 °C]	1.02+
58-72	Not used		
73	Shared PTC Inlet PI Deviation	[%]	1.02+
74-88	Not used		
89-104	Actual Temperature Setpoint (MIC 1 – 16)	[1/10 °C]	1.02+
105-120	Inlet Temperature (MIC 1 – 16)	[1/10 °C]	1.02+
121-136	Outlet Temperature (MIC 1 – 16)	[1/10 °C]	1.02+
137-152	Outlet Temperature 1 (MIC 1 – 16)	[1/10 °C]	1.02+
153-168	Outlet Temperature 2 (MIC 1 – 16)	[1/10 °C]	1.02+
169-184	Hirosensor 1 Temperature 1 (MIC 1 – 16)	[1/10 °C]	1.02+
185-200	Hirosensor 1 Temperature 2 (MIC 1 – 16)	[1/10 °C]	1.02+
201-216	Hirosensor 2 Temperature 1 (MIC 1 – 16)	[1/10 °C]	1.02+
217-232	Hirosensor 2 Temperature 2 (MIC 1 – 16)	[1/10 °C]	1.02+
233-248	Pressure in Circuit 1 (MIC 1 – 16)	[1/10 bar]	1.02+
249-264	Pressure in Circuit 1 (MIC 1 – 16)	[1/10 V]	1.02+
265-280	Pressure in Circuit 2 (MIC 1 – 16)	[1/10 bar]	1.02+
281-296	Pressure in Circuit 2 (MIC 1 – 16)	[1/10 V]	1.02+
297-312	Condenser 1 Analog Output (MIC 1 – 16)	[%]	1.02+
313-328	Condenser 2 Analog Output (MIC 1 – 16)	[%]	1.02+
329-344	User Input Setpoint Shifting (MIC 1 – 16)	[V]	1.02+
345-360	User Input Water Pressure (MIC 1 – 16)	[bar]	1.02+
361-376	User Input Water Pressure (MIC 1 – 16)	[V]	1.02+
377-392	Pump 1 Output Status (MIC 1 – 16)	0 -> Off, 1 -> On	1.02+
393-408	Pump 2 Output Status (MIC 1 – 16)	0 -> Off, 1 -> On	1.02+
409-424	Compressor 1.1 Output Status (MIC 1 – 16)	0 -> Off, 1 -> On	1.02+
425-440	Compressor 1.2 Output Status (MIC 1 – 16)	0 -> Off, 1 -> On	1.02+
441-456	Compressor 2.1 Output Status (MIC 1 – 16)	0 -> Off, 1 -> On	1.02+
457-472	Compressor 2.2 Output Status (MIC 1 – 16)	0 -> Off, 1 -> On	1.02+

473-488	Condenser Fan Output Status (MIC 1 – 16)	0 -> Off, 1 -> On	1.02+
489-504	Flow Switch Input Status (MIC 1 – 16)	0 -> Off, 1 -> On	1.02+
505-520	High Pressure Comp. 1 Input Status (MIC 1 – 16)	0 -> Off, 1 -> On	1.02+
521-536	Low Pressure Comp. 1 Input Status (MIC 1 – 16)	0 -> Off, 1 -> On	1.02+
537-552	Thermal Protection Comp. 1 Input Status (MIC 1 – 16)	0 -> Off, 1 -> On	1.02+
553-568	Oil Pressure Comp. 1 Input Status (MIC 1 – 16)	0 -> Off, 1 -> On	1.02+
569-584	High Pressure Comp. 2 Input Status (MIC 1 – 16)	0 -> Off, 1 -> On	1.02+
585-600	Low Pressure Comp. 2 Input Status (MIC 1 – 16)	0 -> Off, 1 -> On	1.02+
601-616	Thermal Protection Comp. 2 Input Status (MIC 1 – 16)	0 -> Off, 1 -> On	1.02+
617-632	Oil Pressure Comp. 2 Input Status (MIC 1 – 16)	0 -> Off, 1 -> On	1.02+
633-648	Fan Failure Input Status (MIC 1 – 16)	0 -> Off, 1 -> On	1.02+
649-664	Remote Input Status (MIC 1 – 16)	0 -> Off, 1 -> On	1.02+
665-680	User Input Status (MIC 1 – 16)	0 -> Off, 1 -> On	1.02+
681-696	Pump 1 Working Hours (MIC 1 – 16)	[h]	1.02+
697-712	Pump 2 Working Hours (MIC 1 – 16)	[h]	1.02+
713-728	Compressor 1 Working Hours (MIC 1 – 16)	[h]	1.02+
729-744	Compressor 2 Working Hours (MIC 1 – 16)	[h]	1.02+

### Status-Report-Block (Input Register #1 - #6):

Read the document 'Hirolink for Modbus V X.XX - General Documentation' (X.XX is a placeholder for the current version of the Hirolink) for a description on how to use these data-points.

### System-Alarm (Input Register #7) and Single Alarm Status (Input Register #9-#24):

This item holds a value, which represents the current alarm-state of the whole system. This alarm-state is calculated from the single alarm-states of each Microface and holds the highest of those alarm-states. The single alarm-states can be read using the appropriate Holding Registers.

The values correspond to the following states:

- 0 .. No alarm present
- 1 .. Message acknowledged (inactive)
- 3 .. Message acknowledged (active)
- 5 .. Message not acknowledged (inactive)
- 7 .. Message not acknowledged (active)
  
- 9 .. Warning acknowledged (inactive)
- 11 .. Warning acknowledged (active)
- 13 .. Warning not acknowledged (inactive)
- 15 .. Warning not acknowledged (active)
  
- 17 .. Alarm acknowledged (inactive)
- 19 .. Alarm acknowledged (active)
- 21 .. Alarm not acknowledged (inactive)
- 23 .. Alarm not acknowledged (active)
  
- 25 .. Alarm and warning acknowledged (inactive)
- 27 .. Alarm and warning acknowledged (active)
- 29 .. Alarm and warning not acknowledged (inactive)
- 31 .. Alarm and warning not acknowledged (active)

The terms 'acknowledged' and 'not acknowledged' define, if the reset-push-button on the Hiromatic has been pressed once in order to silence the buzzer or if the command 'Alarm Acknowledge' has been performed.

The terms 'active' and 'inactive' define, if the alarm, warning or message is still active, which means that after performing a alarm-reset (either by sending the appropriate command via the Modbus-network or by pressing the reset-push-button on the Hiromatic a second time) the alarm or warning will be reported again.

### System-Status (Input Register #8) and Single Unit Status (Input Registers #25 - #40):

This item holds a value, which represents the current system-state of the whole system and of the single Microfaces. The values correspond to the following states:

- 0 .. Alarm Off      1 .. Manual      2 .. Local Off      3 .. System Off      4 .. Standby Alarm
- 5 .. Standby        6 .. Sleep / Off    7 .. System On     8 .. Warning On    9 .. Alarm On
- 10 .. Sleep

## 3.5 Events

### 3.5.1 Event-Registers

Starting from 'Hirolink for Modbus - V 2.86', there is the possibility to read the current state of a single event through Input-Registers, where each bit of these registers represents the state of one event:

Examples:

Input-Register #5001:

State of Hiromatic-events from ID 0 to 15

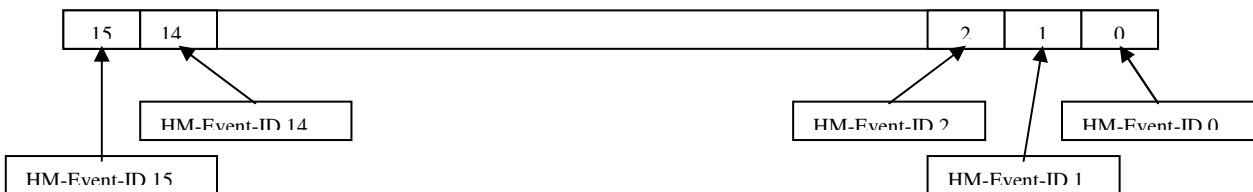

Input-Register #5009:

State of Microface-events from ID 0 to 15 from Microface with ID #1

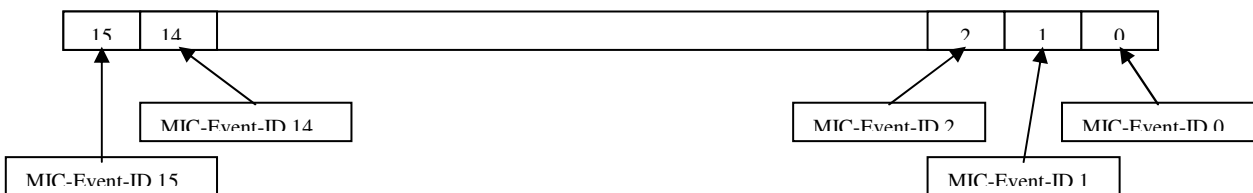

Register #	Usage
5001	Hiromatic-events #0-#15
5002	Hiromatic-events #16-#31
...	...
5008	Hiromatic-events #112-#127
5009	Microface #1-events #0-#15
5010	Microface #1-events #16-#31
...	...
5016	Microface #1-events #112-#127
5017	Microface #2-events #0-#15
5018	Microface #2-events #16-#31
...	...

5024	Microface #2-events #112-#127
...	...
5129	Microface #16-events #0-#15
5130	Microface #16-events #16-#31
...	...
5136	Microface #16-events #112-#127

The following chapter contains a list with all events available for this unit-type. Unused event-IDs will always be set to 0.

**NOTE:**

Events of type 'Message' and 'Reset' (see Event-list in the following chapter), will NOT cause a bit to be set in the Event-registers when they are reported by the Hiromatic. Furthermore, the events 'UNIT CONNECTED' (Event-ID 100) and 'UNIT NOT CONNECTED' (Event-ID 101), which are generated by the Hirolink itself, are also NOT available as single bits within the Event-registers.

These events are only available through the 'Status Report Block' (Input registers #1 - #6).

**For these controls boards and its applications the event registers are upgraded only if the 'Status-Report-Acknowledge' jumper is set; so Hirolink does the upgrades mandatorily** (for more information see Modbus General Documentatio Chapter '5.4 The Status-Report').

### 3.5.2 Event-List

**IMPORTANT:**

Read the document 'Hirolink for Modbus V X.XX - General Documentation' (X.XX is a placeholder for the current version of the Hirolink) for a detailed description on how to use these data-points.

In the following list you can see all Events and Event-IDs available for New Hichill-units:

Event-ID	Event-Description	Event-Type	SW-Version
0	General Alarm	Reset	1.02+
1	Comp. 1 High Pressure	Alarm	1.02+
2	Comp. 1 Low Pressure	Alarm	1.02+
3	Flow Switch Wa	Warning	1.02+
4	Flow Switch AI	Alarm	1.02+
5	User Input Wa	Warning	1.02+
6	User Input AI	Alarm	1.02+
7	Wa High Water Temp. In	Warning	1.02+
8	Wa High Water Temp. Out	Warning	1.02+
9	Wa Low Water Temp. In	Warning	1.02+
10	Wa Low Water Temp. Out	Warning	1.02+
11	AI High Water Temp. In	Alarm	1.02+
12	AI High Water Temp. Out	Alarm	1.02+
13	AI Low Water Temp. In	Alarm	1.02+
14	AI Low Water Temp. Out	Alarm	1.02+
15	Pump 1 Working Hours Exceeded	Warning	1.02+
16	Pump 2 Working Hours Exceeded	Warning	1.02+
17	Comp. 1 Working Hours Exceeded	Warning	1.02+
18	Comp. 2 Working Hours Exceeded	Warning	1.02+
19	Inlet Temp. Sensor Wa	Warning	1.02+
20	Inlet Temp. Sensor AI	Alarm	1.02+
21	Outlet Temp. Sensor 1 Wa	Warning	1.02+
22	Condenser Fan Failure	Warning	1.02+



23	Water Pressure Wa	Warning	1.02+
24	Water Pressure Al	Alarm	1.02+
25	Comp. 2 High Pressure	Alarm	1.02+
26	Comp. 2 Low Pressure	Alarm	1.02+
27	Network Failure (Data Conflict Inside The Bus)	Warning	1.02+
28	Out Of Memory	Warning	1.02+
29	EEPROM Failure	Alarm	1.02+
30	Comp. 1 Thermal Protection	Alarm	1.02+
31	Comp. 2 Thermal Protection	Alarm	1.02+
32	Comp. 1 Oil Pressure	Alarm	1.02+
33	Comp. 2 Oil Pressure	Alarm	1.02+
34	Freeze Circuit 1 Wa (Automatic Reset)	Warning	1.02+
35	Freeze Circuit 2 Wa (Automatic Reset)	Warning	1.02+
36	Unit On	Message	1.02+
37	Unit Off	Message	1.02+
38	Timer Mode	Message	1.02+
39	Standby Mode	Message	1.02+
40	Power On	Message	1.02+
41	Power Off	Message	1.02+
42	Unit 1 Disconnected	Warning	1.02+
43	Unit 2 Disconnected	Warning	1.02+
44	Unit 3 Disconnected	Warning	1.02+
45	Unit 4 Disconnected	Warning	1.02+
46	Unit 5 Disconnected	Warning	1.02+
47	Unit 6 Disconnected	Warning	1.02+
48	Unit 7 Disconnected	Warning	1.02+
49	Unit 8 Disconnected	Warning	1.02+
50	Unit 9 Disconnected	Warning	1.02+
51	Unit 10 Disconnected	Warning	1.02+
52	Unit 11 Disconnected	Warning	1.02+
53	Unit 12 Disconnected	Warning	1.02+
54	Unit 13 Disconnected	Warning	1.02+
55	Unit 14 Disconnected	Warning	1.02+
56	Unit 15 Disconnected	Warning	1.02+
57	Unit 16 Disconnected	Warning	1.02+
58	On-Off By Hiromatic Not Enabled	Warning	1.02+
59	free	-	1.02+
60	free	-	1.02+
61	free	-	1.02+
62	free	-	1.02+
63	Outlet Temp. Sensor 2 Wa	Warning	1.02+
64	No Connection To Unit 1	Warning	1.02+
65	Freeze Circuit 1 Wa (Manual Reset)	Warning	1.02+
66	Freeze Circuit 2 Wa (Manual Reset)	Warning	1.02+

100	UNIT CONNECTED	Message	1.02+
101	UNIT NOT CONNECTED	Message	1.02+

#### 4. Document-Changes

This appendix contains all changes that have been applied to this document up to the current version:

##### 1. Changes from V 1.00 to V 1.01

- The chapter 3.5.1 'Event-Registers' was included.

## **Connectivity**



*the evolution*

## **Hirolink for Modbus**

**(13) Items for Superchiller - Matrix (SCG)  
(Microface).doc**

**English**

02/03/04 Release 1.06E

<b>1.</b>	<b>INTRODUCTION SUPERCHILLER - MATRIX (SCG) (MICROFACE)</b> .....	<b>3</b>
<b>2.</b>	<b>COMPATIBILITY-LIST</b> .....	<b>3</b>
<b>3.</b>	<b>ITEMS FOR SUPERCHILLER - MATRIX (SCG) (MICROFACE)</b> .....	<b>4</b>
3.1	COILS .....	4
3.2	INPUT-STATUS .....	4
3.3	HOLDING REGISTER .....	5
3.4	INPUT-REGISTER .....	7
3.5	EVENTS .....	10
3.5.1	<i>Event-Registers</i> .....	10
3.5.2	<i>Event-List</i> .....	11
<b>4.</b>	<b>DOCUMENT-CHANGES</b> .....	<b>14</b>

# 1. Introduction Superchiller - Matrix (SCG) (Microface)

This document contains a description of all data-points that are available via the 'Hirolink for Modbus' from this type of air-conditioner.

## **IMPORTANT:**

It is vital to the correct integration of the Hirolink into a Modbus-network, that you have read and understood the topics described in the document 'Hirolink for Modbus V X.XX - General Documentation' (X.XX is a placeholder for the current version of the Hirolink). So, if you haven't read this document until now, read it first.

## 2. Compatibility-List

Before connecting a Hiromatic to the Modbus-Hirolink you must check, if the Hiromatic-software-version is compatible with this version of the Hirolink.

You can do this by checking the labels on the eproms, which are inserted into the Hiromatic and the Microface. The eprom inserted in the Hiromatic must be called SCG + Version-Number (e.g. SCG101) and the one inserted in the Microface must be called SCM + Version-Number (e.g. SCM101).

To make sure that the label on the eproms is correct, you should also check the version-information, that the Hiromatic displays shortly after start-up. This information should look similar to the following illustration:

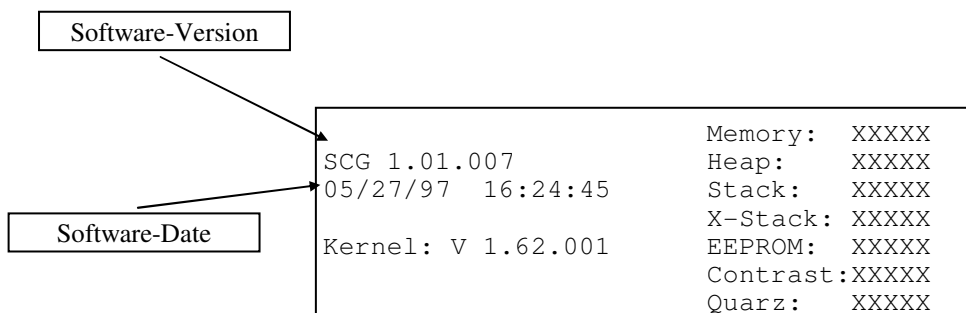

The important information in this window is only the software-version and the software-date (note that the date-format is mm/dd/yy). Make sure that the software-version installed in your installation matches one of the compatible versions listed below:

<b>Version</b>	<b>Date</b>
1.01.007	21/09/1999

### 3. Items for Superchiller - Matrix (SCG) (Microface)

According to the Modbus-protocol-specifications the values and parameters provided by the Hiromatic are represented in 4 groups:

- Coils: Used for changeable, digital values
- Inputs: Used for not changeable, digital values
- Holding Registers: Used for changeable, analog values
- Input Registers: Used for not changeable, analog values

This Hirolink can be compatible with more than one version of this Hiromatic-type and it is possible that there have been extensions in the number of available items from one version to the next.

Therefore the column 'SW-Version' contained in the following lists provides information about the availability of each item depending on the Hiromatic-software-version. For example a entry like '1.15+' means, that this item is available from Hiromatics with software-version 1.15 and higher.

#### **IMPORTANT:**

The available data-points shown in the following chapters are numbered starting from 1, according to the Modbus-Protocol-Specification. Still some BMS start numbering the data-points from 0. So, in case that the BMS you are using starts numbering from 0, you have to decrease the listed numbers by 1.

#### **3.1 Coils**

Not used on this Hiromatic-type.

#### **3.2 Input-Status**

Not used on this Hiromatic-type.

### 3.3 Holding Register

Register #	Hironet	Usage	Range; Unit	SW-Version
1	-	Status-Report-acknowledge	See explanation below	1.01+
2	HMSystemOn	HM-system on/off	0 -> Hiromatic System Off; 1 -> Hiromatic System On	1.01+
3	GenAlarmHM	HM alarm-status	See explanation below	1.01+
4	Units_HM	Number of units	1 - 16;	1.01+
6	Rtc_Min_HM	Minutes of real time clock	0 - 59; [min]	1.01+
7	Rtc_Hou_HM	Hours of real time clock	0 - 23; [h]	1.01+
8	Rtc_Day_HM	Day of real time clock	1 - 31;	1.01+
9	Rtc_Mon_HM	Month of real time clock	1 - 12;	1.01+
10	Rtc_Yea_HM	Year of real time clock	0 - 99;	1.01+
11-17	HMSysOn_Mi	Single unit system on/off (MIC 1 - 8)	0 -> Single Unit Off; 1 -> Single Unit On	1.01+
27-34	GenAlarm	Single alarm-status (MIC 1 - 8)	See explanation below	1.01+
43	ShareEN	Teamwork enabled	0 -> No, 1 -> Yes	1.01+
75	RotationEN	Rotation frequency	0 -> No, 1 -> Daily, 2 -> MO 3 -> TU, 4 -> WE, 5 -> TH 6 -> FR, 7 -> SA, 8 -> SU	1.01+
91	RotatHou	Rotation hour	0 - 23; [h]	1.01+
107	RotatMin	Rotation minute	0 - 59; [min]	1.01+
139	StdByUnits	Number of standby units	0 - 16	1.01+
140-147		Not used		1.01+
187-194	OutTempSet1	Outlet temperature setpoint 1 (MIC 1 - 8)	50 - 170; [1/10 °C]	1.01+
203-210	OuTempSet2	Outlet temperature setpoint 2 (MIC 1 - 8)	4 -> No, 5 - 20; [°C]	<b>1.01</b>
203-210	OuTempSet2	Outlet temperature setpoint 2 (MIC 1 - 8)	-6 (=250) -> No, -5 (=251); -4 (=252); -3 (=253) -2 (=254); -1 (=255) 0 - 20; [°C]	<b>1.02</b>
219-226	Brine_Setp	Brine setpoint (MIC 1 - 8)	-11 -> No, 10 - 25; [°C]	1.01+
267-274	CondSetBar	Condenser setpoint (MIC 1 - 8)	10 - 25; [bar]	1.01+
283-290	CondHysBar	Condenser control hysteresis (MIC 1 - 8)	10 - 100; [1/10 bar]	1.01+
299-306	MinCondSig	Minimum condenser signal (MIC 1 - 8)	0 - 50; [1/10 V]	1.01+
315-322	MaxCondSig	Maximum condenser signal (MIC 1 - 8)	50 - 100; [1/10 V]	1.01+
331-338	HWTemplnWa	High inlet temperature warning (MIC 1 - 8)	0 -> No, 1 - 99; [°C]	1.01+
347-354	LWTemplnWa	Low inlet temperature warning (MIC 1 - 8)	0 -> No, 1 - 99; [°C]	1.01+
363-370	HWTempOuWa	High outlet temperature warning (MIC 1 - 8)	0 -> No, 1 - 99; [°C]	1.01+
379-386	LWTempOuWa	Low outlet temperature warning (MIC 1 - 8)	0 -> No, 1 - 99; [°C]	1.01+
395-402	HWTemplnAl	High inlet temperature alarm (MIC 1 - 8)	0 -> No, 1 - 99; [°C]	1.01+
411-418	LWTemplnAl	Low inlet temperature alarm (MIC 1 - 8)	0 -> No, 1 - 99; [°C]	1.01+
427-434	HWTempOuAl	High outlet temperature alarm (MIC 1 - 8)	0 -> No, 1 - 99; [°C]	1.01+
443-450	LWTempOuAl	Low outlet temperature alarm (MIC 1 - 8)	0 -> No, 1 - 99; [°C]	1.01+
459-466	LWPres_At	Low water pressure at (MIC 1 - 8)	0 -> No, 1 - 10; [bar]	1.01+
475-482	LWPresWaAl	Low water pressure warning or alarm (MIC 1 - 8)	0 -> Warning, 1 -> Alarm	1.01+
491-498	CompLowPrD	Compressor low pressure delay (MIC 1 - 8)	0 - 5; [min]	1.01+
507-514	CompHiPrWa	Compressor high pressure warning (MIC 1 - 8)	0 - 280; [1/10 bar]	1.01+
523-530	FreezeWaAt	Freeze warning at (MIC 1 - 8)	-250 - 50; [1/10 °C]	<b>1.01</b>
523-530	FreezeWaAt	Freeze warning at (MIC 1 - 8)	-260 -> Switch; -250 - 50; [1/10 °C]	<b>1.02</b>
539-546	FreezeAuMa	Auto or manual reset of freeze warnings (MIC 1 - 8)	0 -> Automatic, 1 -> Manual	1.01+
555-562	HourPump1	Pump 1 working hours (MIC 1 - 8)	0 - 32000; [h]	1.01+
571-578	HourPump2	Pump 2 working hours (MIC 1 - 8)	0 - 32000; [h]	1.01+
587-595	HourComp1	Circuit 1 working hours (MIC 1 - 8)	0 - 32000; [h]	1.01+
603-610	HourComp1	Circuit 2 working hours (MIC 1 - 8)	0 - 32000; [h]	1.01+
715-722	HourComp3	Circuit 3 working hours (MIC 1 - 8)	0 - 32000; [h]	1.02+
731-738	HourComp4	Circuit 4 working hours (MIC 1 - 8)	0 - 32000; [h]	1.02+
619-626	HourFC	Freecooling on working hours (MIC 1 - 8)	0 - 32000; [h]	1.01+
635-642	HourPump1M	Pump 1 working hours warning at (MIC 1 - 8)	0 - 32000; [h]	1.01+
651-658	HourPump2M	Pump 2 working hours warning at (MIC 1 - 8)	0 - 32000; [h]	1.01+
667-674	HourComp1M	Circuit 1 working hours warning at (MIC 1 - 8)	0 - 32000; [h]	1.01+
683-690	HourComp1M	Circuit 2 working hours warning at (MIC 1 - 8)	0 - 32000; [h]	1.01+
747-754	HourComp3M	Circuit 3 working hours warning at (MIC 1 - 8)	0 - 32000; [h]	1.02+
763-770	HourComp4M	Circuit 4 working hours warning at (MIC 1 - 8)	0 - 32000; [h]	1.02+
699-706	HourFCM	Freecooling on working hours warning at (MIC 1 - 8)	0 - 32000; [h]	1.01+

## Status-Report-Acknowledge (Holding Register #1):

Read the document 'Hirolink for Modbus V X.XX - General Documentation' (X.XX is a placeholder for the current version of the Hirolink) for a description on how to use this data-point.

## HM Alarm Status (Holding Register #3) and Single Alarm-Status (Holding Registers #27 - #42):

This item holds a value, which represents the current alarm-state of the Hiromatic and the single Microfaces.

It can be written to in order to perform either a 'Alarm Acknowledge'- or a 'Alarm Reset'-command on the Hiromatic or a single Microface:

### 2 .. Alarm Reset:

This command will reset all alarms, warnings and messages currently present on the Hiromatic or Microface. As a consequence alarms, warnings and messages that are inactive will disappear, will active alarms, warnings and messages will be reported again.

### 4 .. Alarm Acknowledge:

This command will acknowledge all alarms, warnings and messages present on the Hiromatic or Microface. As a consequence alarms, warnings and messages that were in an unacknowledged state will be acknowledged after the command.

When read, the value corresponds to the following states:

- 0 .. No alarm present
- 1 .. Message acknowledged (inactive)
- 3 .. Message acknowledged (active)
- 5 .. Message not acknowledged (inactive)
- 7 .. Message not acknowledged (active)
  
- 9 .. Warning acknowledged (inactive)
- 11.. Warning acknowledged (active)
- 13.. Warning not acknowledged (inactive)
- 15.. Warning not acknowledged (active)
  
- 17.. Alarm acknowledged (inactive)
- 19.. Alarm acknowledged (active)
- 21...Alarm not acknowledged (inactive)
- 23.. Alarm not acknowledged (active)
  
- 25.. Alarm and warning acknowledged (inactive)
- 27.. Alarm and warning acknowledged (active)
- 29.. Alarm and warning not acknowledged (inactive)
- 31.. Alarm and warning not acknowledged (active)

The terms 'acknowledged' and 'not acknowledged' define, if the reset-push-button on the Hiromatic has been pressed once in order to silence the buzzer or if the command 'Alarm Acknowledge' has been performed.

The terms 'active' and 'inactive' define, if the alarm, warning or message is still active, which means that after performing a alarm-reset (either by sending the appropriate command via the Modbus-network or by pressing the reset-push-button on the Hiromatic a second time) the alarm or warning will be reported again.

### **NOTE:**

Although you can read the alarm-state of the whole system, it is not possible to issue a 'Alarm Acknowledge'- or 'Alarm Reset'-command for the whole system. Instead you have to issue these commands for each Microface separately.



### 3.4 Input-Register

Register #	Hironet-Variable	Usage	Range; Unit	SW-Version
1	-	Event-ID	ID identifying the event	1.01+
2	-	Controller-ID	Controller-ID, where the event occurred	1.01+
3	-	Minute	Minute, when event occurred	1.01+
4	-	Hour	Hour, when event occurred	1.01+
5	-	Date	Date, when event occurred	1.01+
6	-	Event-type	0 -> message, 1 -> warning 2 -> alarm, 3 and 4 -> reset	1.01+
7	SysState	System status	See explanation below	1.01+
8	SysAlarm	System alarm	See explanation below	1.01+
9-16	SinglState	Single status (MIC 1 - 8)	See explanation below	1.01+
25-32	UnitAlarm	Single alarm status (MIC 1 - 8)	See explanation below	1.01+
41	TempSet_ac	Actual temperature Setpoint	-100 - 300; [1/10 °C]	1.01+
57	ShPTCIn_Te	Shared PTC inlet temperature	-250 - 1000; [1/10 °C]	1.01+
73	ShPTCOu_Te	Shared PTC outlet temperature	-250 - 1000; [1/10 °C]	1.01+
89	ShPTCAm_Te	Shared PTC ambient temperature	-300 - 300; [1/10 °C]	1.01+
105	ShPTCEv_Te	Shared PTC evaporator inlet temp.	-250 - 250; [1/10 °C]	1.01+
153-160	PTCIn_Temp	PTC inlet temperature (MIC 1 - 8)	-250 - 1000; [1/10 °C]	1.01+
169-176	PTCOu_Temp	PTC outlet temperature (MIC 1 - 8)	-250 - 1000; [1/10 °C]	1.01+
185-192	PTCOu1_Tem	PTC outlet 1 temperature (MIC 1 - 8)	-250 - 1000; [1/10 °C]	1.01+
201-208	PTCOu2_Tem	PTC outlet 2 temperature (MIC 1 - 8)	-250 - 1000; [1/10 °C]	1.01+
217-224	PTCAmb_Tem	PTC ambient temperature (MIC 1 - 8)	-300 - 1000; [1/10 °C]	1.01+
233-240	PTCEva_Tem	PTC evaporator inlet temp. (MIC 1 - 8)	-250 - 1000; [1/10 °C]	1.01+
329-336	FC_Cond	FC condition (MIC 1 - 8)	0->Off, 1->not used, 2->On	1.01+
345-352	InRemStat	Remote input status (MIC 1 - 8)	0->Off, 1->On	1.01
345-352	InRemStat	Remote input status (MIC 1 - 8)	1->Off, 0->On	1.02
361-368	InFlowStat	Flow input status (MIC 1 - 8)	0->Ok, 1->Off, 2->Warning, 3->Alarm, 4->Time	1.01+
377-384	InFanStat	Fan input status 1 (MIC 1 - 8)	0->OK, 1->Warning / Alarm	1.01+
633-640	InFan2Stat	Fan input status 2 (MIC 1 - 8)	0->OK, 1->Warning / Alarm	1.02+
649-656	InFan3Stat	Fan input status 3 (MIC 1 - 8)	0->OK, 1->Warning / Alarm	1.02+
665-672	InFan4Stat	Fan input status 4 (MIC 1 - 8)	0->OK, 1->Warning / Alarm	1.02+
393-400	InUsrStat	User input 1 status (MIC 1 - 8)	0->Ok, 1->Warning, 2->Alarm, 3->STO1, 4->STO2, 5->S FC, 6->F FC, 7->SET1, 8->SET2, 9->B SP, 10->Sh S, 11->Pr S, 12->Start Standby	1.01+
681-688	InUsr2Stat	User input 2 status (MIC 1 - 8)	0->Ok, 1->Warning, 2->Alarm, 3->STO1, 4->STO2, 5->S FC, 6->F FC, 7->SET1, 8->SET2, 9->B SP, 10->Sh S, 11->Pr S, 12->Start Standby	1.02+
409-416	InLP1Stat	Low pressure 1 input status (MIC 1 - 8)	0->Ok, 1->Off, 2->Alarm, 3->Time	1.01+
425-432	InLP2Stat	Low pressure 2 input status (MIC 1 - 8)	0->Ok, 1->Off, 2->Alarm, 3->Time	1.01+
697-704	InLP3Stat	Low pressure 3 input status (MIC 1 - 8)	0->Ok, 1->Off, 2->Alarm, 3->Time	1.02+
713-720	InLP4Stat	Low pressure 4 input status (MIC 1 - 8)	0->Ok, 1->Off, 2->Alarm, 3->Time	1.02+
441-448	InHP1Stat	High pressure 1 input status (MIC 1 - 8)	0->Ok, 1->Off, 2->Alarm	1.01+
457-465	InHP2Stat	High pressure 2 input status (MIC 1 - 8)	0->Ok, 1->Off, 2->Alarm	1.01+
729-736	InHP3Stat	High pressure 3 input status (MIC 1 - 8)	0->Ok, 1->Off, 2->Alarm	1.02+
745-752	InHP4Stat	High pressure 4 input status (MIC 1 - 8)	0->Ok, 1->Off, 2->Alarm	1.02+
473-480	InTH1Stat	Thermal prot. 1 input status (MIC 1 - 8)	0->OK, 2-> Alarm	1.01+
489-496	InTH2Stat	Thermal prot. 2 input status (MIC 1 - 8)	0->OK, 2-> Alarm	1.01+
761-768	InTH3Stat	Thermal prot. 3 input status (MIC 1 - 8)	0->OK, 2-> Alarm	1.02+
777-784	InTH4Stat	Thermal prot. 4 input status (MIC 1 - 8)	0->OK, 2-> Alarm	1.02+
505-512	InOil1Stat	Oil pressure 1 input status (MIC 1 - 8)	0->OK, 2-> Alarm	1.01+
521-528	InOil2Stat	Oil pressure 2 input status (MIC 1 - 8)	0->OK, 2-> Alarm	1.01+
793-800	InOil3Stat	Oil pressure 3 input status (MIC 1 - 8)	0->OK, 2-> Alarm	1.02+
809-816	InOil4Stat	Oil pressure 4 input status (MIC 1 - 8)	0->OK, 2-> Alarm	1.02+
825-832	InFr1Stat	Antifreeze 1 input status (MIC 1 - 8)	0->Ok, 1->Warning	1.02+
841-848	InFr2Stat	Antifreeze 2 input status (MIC 1 - 8)	0->Ok, 1-> Warning	1.02+
537-544	ManPump1	Pump 1 status (MIC 1 - 8)	0->Off, 1->On	1.01+
553-560	ManPump2	Pump 2 status (MIC 1 - 8)	0->Off, 1->On	1.01+
569-576	ManComp1	Compressor 1 step 1 status (MIC 1 - 8)	0->Off, 1->On	1.01+
585-592	ManComp1Pa	Compressor 1 step 2 status (MIC 1 - 8)	0->Off, 1->On	1.01+
601-608	ManComp2	Compressor 2 step 1 status (MIC 1 - 8)	0->Off, 1->On	1.01+

617-624	ManComp2Pa	Compressor 2 step 2 status (MIC 1 – 8)	0->Off, 1->On	1.01+
857-864	ManComp3	Compressor 3 status (MIC 1 - 8)	0->Off, 1->On	1.02+
873-880	ManComp4	Compressor 4 status (MIC 1 - 8)	0->Off, 1->On	1.02+
889-896	C1PresBar	Circuit 1 Pressure	-6 – 300 [1/10 bar]	1.02+
905-912	C2PresBar	Circuit 2 Pressure	-6 – 300 [1/10 bar]	1.02+
921-928	C3PresBar	Circuit 3 Pressure	-6 – 300 [1/10 bar]	1.02+
937-974	C4PresBar	Circuit 4 Pressure	-6 – 300 [1/10 bar]	1.02+

### Status-Report-Block (Input Register #1 - #6):

Read the document 'Hirolink for Modbus V X.XX - General Documentation' (X.XX is a placeholder for the current version of the Hirolink) for a description on how to use these data-points.

### System-Alarm (Input Register #8):

This item holds a value, which represents the current alarm-state of the whole system. This alarm-state is calculated from the single alarm-states of each Microface and holds the highest of those alarm-states. The single alarm-states can be read using the appropriate Holding Registers. The values correspond to the following states:

- 0 .. No alarm present
- 1 .. Message acknowledged (inactive)
- 3 .. Message acknowledged (active)
- 5 .. Message not acknowledged (inactive)
- 7 .. Message not acknowledged (active)
  
- 9 .. Warning acknowledged (inactive)
- 11 .. Warning acknowledged (active)
- 13 .. Warning not acknowledged (inactive)
- 15 .. Warning not acknowledged (active)
  
- 17 .. Alarm acknowledged (inactive)
- 19 .. Alarm acknowledged (active)
- 21 .. Alarm not acknowledged (inactive)
- 23 .. Alarm not acknowledged (active)
  
- 25 .. Alarm and warning acknowledged (inactive)
- 27 .. Alarm and warning acknowledged (active)
- 29 .. Alarm and warning not acknowledged (inactive)
- 31 .. Alarm and warning not acknowledged (active)

The terms 'acknowledged' and 'not acknowledged' define, if the reset-push-button on the Hiromatic has been pressed once in order to silence the buzzer or if the command 'Alarm Acknowledge' has been performed.

The terms 'active' and 'inactive' define, if the alarm, warning or message is still active, which means that after performing a alarm-reset (either by sending the appropriate command via the Modbus-network or by pressing the reset-push-button on the Hiromatic a second time) the alarm or warning will be reported again.

### System-Status (Input Register #7) and Single Status (Input Registers #9 - #24):

This item holds a value, which represents the current system-state of the whole system and of the single Microfaces. The values correspond to the following states:

- 0 .. Alarm Off      1 .. Manual      2 .. Local Off      3 .. System Off
- 4 .. Standby/Alarm   5 .. Standby      6 .. Sleep / Off    7 .. System On
- 8 .. Warning On     9 .. Alarm On    10 .. Sleep

## Single Alarm Status (Input Register #25 - #40):

This item holds a value, which represents the current alarm-state of the whole system. This alarm-state is calculated from the single alarm-states of each Microface and holds the highest of those alarm-states. The single alarm-states can also be read using the appropriate Holding Registers.

The values correspond to the following states:

- 0 .. No alarm present
- 1 .. Message acknowledged (inactive)
- 3 .. Message acknowledged (active)
- 5 .. Message not acknowledged (inactive)
- 7 .. Message not acknowledged (active)
  
- 9 .. Warning acknowledged (inactive)
- 11 .. Warning acknowledged (active)
- 13 .. Warning not acknowledged (inactive)
- 15 .. Warning not acknowledged (active)
  
- 17 .. Alarm acknowledged (inactive)
- 19 .. Alarm acknowledged (active)
- 21 .. Alarm not acknowledged (inactive)
- 23 .. Alarm not acknowledged (active)
  
- 25 .. Alarm and warning acknowledged (inactive)
- 27 .. Alarm and warning acknowledged (active)
- 29 .. Alarm and warning not acknowledged (inactive)
- 31 .. Alarm and warning not acknowledged (active)

The terms 'acknowledged' and 'not acknowledged' define, if the reset-push-button on the Hiromatic has been pressed once in order to silence the buzzer or if the command 'Alarm Acknowledge' has been performed.

The terms 'active' and 'inactive' define, if the alarm, warning or message is still active, which means that after performing a alarm-reset (either by sending the appropriate command via the Modbus-network or by pressing the reset-push-button on the Hiromatic a second time) the alarm or warning will be reported again.

### 3.5 Events

#### 3.5.1 Event-Registers

Starting from 'Hirolink for Modbus - V 2.86', there is the possibility to read the current state of a single event through Input-Registers, where each bit of these registers represents the state of one event:

Examples:

Input-Register #5001:

State of Hiromatic-events from ID 0 to 15

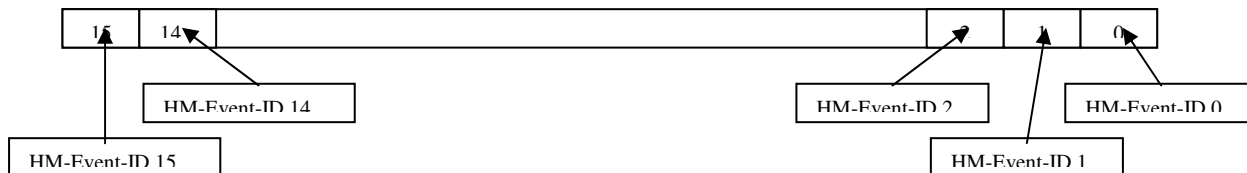

Input-Register #5009:

State of Microface-events from ID 0 to 15 from Microface with ID #1

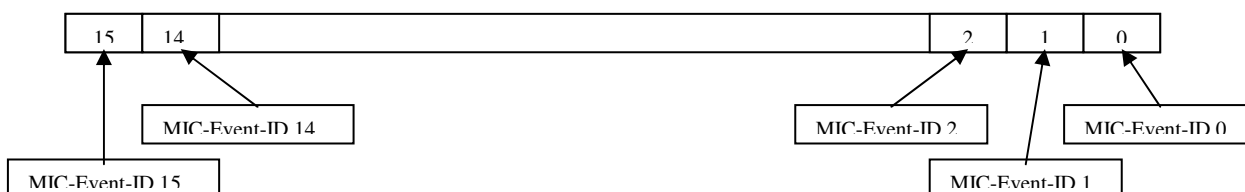

Register #	Usage
5001	Hiromatic-events #0-#15
5002	Hiromatic-events #16-#31
...	...
5008	Hiromatic-events #112-#127
5009	Hiromatic-events #128-#129
5010	Microface #1-events #0-#15
5011	Microface #1-events #16-#31
...	...
5017	Microface #1-events #112-#127
5018	Microface #1-events #128-#129
5019	Microface #2-events #0-#15
5020	Microface #2-events #16-#31
...	...
5027	Microface #2-events #128-#129
...	...
5073	Microface #8-events #0-#15
5074	Microface #8-events #16-#31
...	...
5081	Microface #8-events #128-#129
...	...

The following chapter contains a list with all events available for this unit-type. Unused event-IDs will always be set to 0.

**NOTE:**

Events of type 'Message' and 'Reset' (see Event-list in the following chapter), will NOT cause a bit to be set in the Event-registers when they are reported by the Hiromatic. Furthermore, the events 'UNIT CONNECTED' (Event-ID 100) and 'UNIT NOT CONNECTED' (Event-ID 101), which are generated by the Hirolink itself, are also NOT available as single bits within the Event-registers. These events are only available through the 'Status Report Block' (Input registers #1 - #6).

**For these controls boards and its applications the event registers are upgraded only if the 'Status-Report-Acknowledge' jumper is set; so Hirolink does the upgrades mandatorily** (for more information see Modbus General Documentatio Chapter '5.4 The Status-Report').

### 3.5.2 Event-List

#### **IMPORTANT:**

Read the document 'Hirolink for Modbus V X.XX - General Documentation' (X.XX is a placeholder for the current version of the Hirolink) for a detailed description on how to use these data-points.

In the following list you can see all Events and Event-IDs available for Superchiller-units:

Event-ID	Event-Description	Event-Type	SW-Version
0	GENERAL ALARM	Reset	1.01+
1	COMP. 1 HIGH PRESSURE	Alarm	1.01+
2	COMPRESSOR 1 LOW PRESSURE	Alarm	1.01+
3	FLOW SWITCH WARNING	Warning	1.01+
4	FLOW SWITCH ALARM	Alarm	1.01+
5	USER INPUT TRIGGERED	Warning	1.01+
6	USER INPUT TRIGGERED	Alarm	1.01+
7	HIGH WATER TEMP. IN	Warning	1.01+
8	HIGH WATER TEMP. OUT	Warning	1.01+
9	LOW WATER TEMP. IN	Warning	1.01+
10	LOW WATER TEMP. OUT	Warning	1.01+
11	HIGH WATER TEMP. IN	Warning	1.01+
12	HIGH WATER TEMP. OUT	Alarm	1.01+
13	LOW WATER TEMP. IN	Alarm	1.01+
14	LOW WATER TEMP. OUT	Alarm	1.01+
15	PUMP 1 WORKING HOURS EXCEEDED	Warning	1.01+
16	PUMP 2 WORKING HOURS EXCEEDED	Warning	1.01+
17	CIRCUIT 1 WORKING HOURS EXCEEDED	Warning	1.01+
18	CIRCUIT 2 WORKING HOURS EXCEEDED	Warning	1.01+
19	INLET TEMPERATURE SENSOR FAILURE	Warning	1.01+
20	INLET TEMPERATURE SENSOR FAILURE	Alarm	1.01+
21	OUTLET TEMPERATURE SENSOR 1 FAILURE	Warning	1.01+
22	CONDENSER 1 FANS FAILURE	Warning	1.01+
23	WATER PRESSURE WARNING	Warning	1.01+
24	WATER PRESSURE ALARM	Alarm	1.01+
25	COMP. 2 HIGH PRESSURE	Alarm	1.01+
26	COMPRESSOR 2 LOW PRESSURE	Alarm	1.01+
27	NETWORK FAILURE	Warning	1.01+
28	OUT OF MEMORY / EEPROM FAILURE	Warning	1.01+
29	COMPRESSOR NOT STOPPING PLS CHECK MF OUTPUTS	Alarm	1.01+
30	COMPRESSOR 1 THERMAL PROTECTION	Alarm	1.01+
31	COMPRESSOR 2 THERMAL PROTECTION	Alarm	1.01+
32	COMPRESSOR 1 OIL PRESSURE	Alarm	1.01+
33	COMPRESSOR 2 OIL PRESSURE	Alarm	1.01+
34	FREEZE ALARM (Auto-Reset)	Alarm	1.01+
35	FREEZE ALARM COMP.2 (Auto-Reset)	Alarm	1.01+
36	UNIT ON	Message	1.01+
37	UNIT OFF	Message	1.01+
38	TIMER MODE	Message	1.01+
39	STANDBY MODE	Message	1.01+
40	POWER ON	Message	1.01+
41	POWER OFF	Message	1.01+
42	Unit 1 disconnected	Warning	1.01+
43	Unit 2 disconnected	Warning	1.01+
44	Unit 3 disconnected	Warning	1.01+
45	Unit 4 disconnected	Warning	1.01+

46	Unit 5 disconnected	Warning	1.01+
47	Unit 6 disconnected	Warning	1.01+
48	Unit 7 disconnected	Warning	1.01+
49	Unit 8 disconnected	Warning	1.01+
50	Unit 9 disconnected	Warning	1.01+
51	Unit 10 disconnected	Warning	1.01+
52	Unit 11 disconnected	Warning	1.01+
53	Unit 12 disconnected	Warning	1.01+
54	Unit 13 disconnected	Warning	1.01+
55	Unit 14 disconnected	Warning	1.01+
56	Unit 15 disconnected	Warning	1.01+
57	Unit 16 disconnected	Warning	1.01+
58	ON-OFF BY HIROMATIC NOT ENABLED	Warning	1.01+
59	COMPRESSOR 1 HIGH PRESSURE WARNING	Warning	1.01+
60	COMPRESSOR 2 HIGH PRESSURE WARNING	Warning	1.01+
61	COMPRESSOR 1 HIGH PRESSURE WARNING OK	Warning	1.01+
62	COMPRESSOR 2 HIGH PRESSURE WARNING OK	Warning	1.01+
63	OUTLET TEMPERATURE SENSOR 2 FAILURE	Warning	1.01+
64	NO CONNECTION TO UNIT 1	Warning	1.01+
65	FREEZE ALARM (Manual Reset)	Warning	1.01+
66	FREEZE ALARM COMP.2 (Manual Reset)	Warning	1.01+
67	OUT OF MEMORY (Hiromatic)	Warning	1.01+
68	CONDENSER 1 FANS FAILURE ALARM	Alarm	1.01+
69	AMBIENT TEMP. SENSOR WARNING	Warning	1.01+
70	OUTLET TEMPERATURE SENSOR 1 FAILURE	Alarm	1.01+
71	OUTLET TEMPERATURE SENSOR 2 FAILURE	Alarm	1.01+
72	EVAPORATOR INLET SENSOR WARNING	Warning	1.01+
73	EVAPORATOR INLET SENSOR ALARM	Alarm	1.01+
74	EVAPORATOR INLET SENSOR WARNING (TEAM)	Warning	1.01+
75	EVAPORATOR INLET SENSOR ALARM (TEAM)	Alarm	1.01+
76	INLET TEMPERATURE SENSOR FAILURE (TEAM)	Warning	1.01+
77	HIROBUS ERROR	Warning	1.01+
78	SUBGROUP-ID NOT UNIQUE	Warning	1.01+
79	SUBGROUP-UNIT 1 NOT CONNECTED	Warning	1.01+
80	SUBGROUP-UNIT 2 NOT CONNECTED	Warning	1.01+
81	FC WORKING HOURS EXCEEDED	Warning	1.01+
82	CONDENSER 2 FANS FAILURE	Warning	1.01+
83	CONDENSER 2 FANS FAILURE ALARM	Alarm	1.01+
84	LOW CONDENSER PRESSURE 1	Alarm	1.01+
85	LOW CONDENSER PRESSURE 2	Alarm	1.01+
86	COMP. 1 HIGH PRESSURE / TH. PROTECTION	Alarm	1.01+
87	COMP. 2 HIGH PRESSURE / TH. PROTECTION	Alarm	1.01+
88	SUBGROUP-UNIT 1 NOT CONNECTED	Alarm	1.01+
89	SUBGROUP-UNIT 2 NOT CONNECTED	Alarm	1.01+
90	NO DIFFERENTIAL PRESSURE COMP.1	Alarm	1.01+
91	NO DIFFERENTIAL PRESSURE COMP.2	Alarm	1.01+
92	SLAVE MICROFACE NOT CONNECTED	Alarm	1.01+
93	HIROSENSOR 1 FAILURE	Warning	1.01+
94	HIROSENSOR 2 FAILURE	Warning	1.02+
95	CONDENSER 3 FANS FAILURE ALARM	Alarm	1.02+
96	CONDENSER 4 FANS FAILURE ALARM	Alarm	1.02+
97	COMP. 3 HIGH PRESSURE / TH. PROTECTION	Alarm	1.02+
98	COMP. 4 HIGH PRESSURE / TH. PROTECTION	Alarm	1.02+
99	COMP. 3 HIGH PRESSURE	Alarm	1.02+

100	UNIT CONNECTED	Message	1.01+
101	UNIT NOT CONNECTED	Message	1.01+

102	COMP. 4 HIGH PRESSURE	Alarm	1.02+
-----	-----------------------	-------	-------

103	COMPRESSOR 3 LOW PRESSURE	Alarm	1.02+
104	COMPRESSOR 4 LOW PRESSURE	Alarm	1.02+
105	COMPRESSOR 3 OIL PRESSURE	Alarm	1.02+
106	COMPRESSOR 4 OIL PRESSURE	Alarm	1.02+
107	COMPRESSOR 3 THERMAL PROTECTION	Alarm	1.02+
108	COMPRESSOR 4 THERMAL PROTECTION	Alarm	1.02+
109	LOW CONDENSER PRESSURE 3	Alarm	1.02+
110	LOW CONDENSER PRESSURE 4	Alarm	1.02+
111	NO DIFFERENTIAL PRESSURE COMP.3	Alarm	1.02+
112	NO DIFFERENTIAL PRESSURE COMP.4	Alarm	1.02+
113	COMPRESSOR 3 HIGH PRESSURE WARNING OK	Warning	1.02+
114	COMPRESSOR 4 HIGH PRESSURE WARNING OK	Warning	1.02+
115	COMPRESSOR 3 HIGH PRESSURE WARNING	Warning	1.02+
116	COMPRESSOR 4 HIGH PRESSURE WARNING	Warning	1.02+
117	SUBGROUP-UNIT 3 NOT CONNECTED	Alarm	1.02+
118	SUBGROUP-UNIT 4 NOT CONNECTED	Alarm	1.02+
119	SUBGROUP-UNIT 3 NOT CONNECTED	Alarm	1.02+
120	SUBGROUP-UNIT 4 NOT CONNECTED	Alarm	1.02+
121	CIRCUIT 3 WORKING HOURS EXCEEDED	Warning	1.02+
122	CIRCUIT 4 WORKING HOURS EXCEEDED	Warning	1.02+
123	CONDENSER 3 FANS FAILURE	Alarm	1.02+
124	CONDENSER 4 FANS FAILURE	Alarm	1.02+
125	SLAVE MICROFACE 2 NOT CONNECTED	Alarm	1.02+
126	USER INPUT 2 TRIGGERED	Warning	1.02+
127	USER INPUT 2 TRIGGERED	Alarm	1.02+

## 4. Document-Changes

This appendix contains all changes that have been applied to this document up to the current version:

### 1. Changes from V 1.00 to V 1.01

The following Holding registers were changed or corrected:

- Holding register #59 'Cascade enabled' was removed.
- Holding register #75 'Rotation enabled' was changed to 'Rotation frequency'.
- Holding register #123 'Microface rotation enabled' was removed.
- Holding registers #155-#170 'Outlet temperature setpoint (MIC 1-16)' were removed.
- Holding registers #171-#186 'Outlet temp. setpoint in timer mode (MIC 1-16)' removed.
- Holding registers #235-#250 'Temperature proportional band (MIC 1-16)' were removed.
- Holding registers #251-#266 'Temperature integration factor (MIC 1-16)' were removed.
- Holding registers #587-#602 'Compressor 1 working hours' were renamed to 'Circuit 1 working hours'.
- Holding registers #603-#618 'Compressor 2 working hours' were renamed to 'Circuit 2 working hours'.
- Holding registers #667-#682 'Compressor 1 working hours warning at' were renamed to 'Circuit 1 working hours'.
- Holding registers #683-#698 'Compressor 2 working hours warning at' were renamed to 'Circuit 2 working hours'.

The following Input registers were changed or corrected:

- Input register #6 'Event type': A value of 1 indicates a warning and a value of 2 indicates an alarm and not vice versa as written in previous versions of this document.
- Input register #121 'Shared inlet PI deviation' was removed.
- Input register #137 'Shared evaporator PI deviation' was removed.
- Input registers #249-#264 'PI deviation (MIC 1 - 8)' were removed.
- Input registers #265-#280 'Hiro sensor 1 temperature 1 (MIC 1 - 8)' were removed.
- Input registers #281-#296 'Hiro sensor 1 temperature 2 (MIC 1 - 8)' were removed.
- Input registers #297-#312 'Hiro sensor 2 temperature 1 (MIC 1 - 8)' were removed.
- Input registers #313-#328 'Hiro sensor 2 temperature 2 (MIC 1 - 8)' were removed.

A new column holding the relevant Hiromatic-parameter-numbers was included in the Holding register list.

### 2. Changes from V 1.01 to V 1.02

The following Input registers were added:

- Input registers #537-#552 'Pump 1 status'.
- Input registers #553-#568 'Pump 2 status'.
- Input registers #569-#584 'Compressor 1 step 1 status'.
- Input registers #585-#600 'Compressor 1 step 2 status'.
- Input registers #601-#616 'Compressor 2 step 1 status'.
- Input registers #617-#632 'Compressor 2 step 2 status'.

### 3. Changes from V 1.02 to V 1.03

- Alarm List for 1.01 version updated
- Items + Alarms added for 1.02 versions
- Hironet variable added

### 4. Changes from V 1.03 to V 1.04

- Parameter List for 1.02 version corrected (minor corrections)

### 5. Changes from V 1.04 to V 1.05

- Parameter List for 1.02 version corrected (minor corrections)
- Pressure indications added in Input register (889 -944)



## Connectivity



*the evolution*

## Hirolink for Modbus

**(14) Items for CAM - HIVAR (HVM) (Microface).doc**

English

23/05/07 Release 1.01E

<b>1.</b>	<b>INTRODUCTION CAM - HIVAR (HVM) (MICROFACE)</b> .....	<b>3</b>
<b>2.</b>	<b>COMPATIBILITY-LIST</b> .....	<b>3</b>
<b>3.</b>	<b>ITEMS FOR FOR CAM - HIVAR (HVM) (MICROFACE)</b> .....	<b>3</b>
3.1	COILS.....	3
3.2	INPUT-STATUS.....	3
3.3	HOLDING REGISTER.....	4
3.4	INPUT-REGISTER .....	8
3.5	EVENTS.....	10
3.5.1	<i>Event-List</i> .....	10
<b>4.</b>	<b>DOCUMENT-CHANGES</b> .....	<b>11</b>

## 1. Introduction CAM - HIVAR (HVM) (Microface)

This document contains a description of all data-points that are available via the 'Hirolink for Modbus' from this type of air-conditioner.

### **IMPORTANT 1:**

Units of the above mentioned type do not use Hiromatic to connect to the Hirolink Modbus, but data are transmitted directly from the Microface RS485 port (multiple units need to be interconnected with Hirobus as well with Hironet cable (Hironet uses T-connectors, as there is only 1 RS485 connector on the Microface). Cabling / pinning exactly like Hiromatic E, see Hironet Connection Guide cod.272179).

### **IMPORTANT 2:**

It is vital to the correct integration of the Hirolink into a Modbus-network, that you have read and understood the topics described in the document 'Hirolink for Modbus V X.XX - General Documentation' (X.XX is a placeholder for the current version of the Hirolink). So, if you haven't read this document until now, read it first.

## 2. Compatibility-List

Before connecting a Microface to the Modbus-Hirolink you must check, if the Microface-software-version is compatible with this version of the Hirolink.

You can do this by checking the labels on the Eproms, which are inserted into the Microface. The Eprom inserted in the Microface must be called HVM + Version-Number (e.g. **HVM 1.00.025**).

## 3. Items for for CAM - HIVAR (HVM) (Microface)

According to the Modbus-protocol-specifications the values and parameters provided by the Microface are represented in 4 groups:

- Coils: Used for changeable, digital values
- Inputs: Used for not changeable, digital values
- Holding Registers: Used for changeable, analog values
- Input Registers: Used for not changeable, analog values

This Hirolink can be compatible with more than one version of this Microface-type and it is possible that there have been extensions in the number of available items from one version to the next.

Therefore the column 'SW-Version' contained in the following lists provides information about the availability of each item depending on the Hiromatic-software-version. For example a entry like '1.00+' means, that this item is available from Hiromatics with software-version 1.00 and higher.

### **IMPORTANT:**

The available data-points shown in the following chapters are numbered starting from 1, according to the Modbus-Protocol-Specification. Still some BMS start numbering the data-points from 0. So, in case that the BMS you are using starts numbering from 0, you have to decrease the listed numbers by 1.

### **3.1 Coils**

Not used on this application.

### **3.2 Input-Status**

Not used on this application.

### 3.3 Holding Register

Reg. #	Hironet	Usage	Range; Unit	SW-Version
1		Status Report acknowledge	See explanation below	1.00.025+
2	HMSysOn_Mi	Unit on/off	0 -> Unit Off; 1 -> Unit On	1.00.025+
3	GenAlarm	Unit alarm state	See explanation below	1.00.025+
4	RecoveryHL	Recovery mode	0 -> normal; 1 -> Recovery	1.00.025+
5	HL_BMS_Off	Unit off by BMS	0 -> On; 1 -> BMS off <b>(must be repeated every 45 seconds)</b>	1.00.025+
7	Rtc_Min	Time (minutes)	0 - 59 [min]	1.00.025+
8	Rtc_Hou	Time (hours)	0 - 23 [h]	1.00.025+
9	Rtc_Day	Date (day)	1 - 31	1.00.025+
10	Rtc_Mon	Date (month)	1 - 12	1.00.025+
11	Rtc_Yea	Date (year)	0 - 99	1.00.025+
13	Units_Mic	Number of units connected	1 - 16	1.00.025+
15	AuRestart	Auto-restart time	1 - 999 [sec]	1.00.025+
16	RemoteEN	Hiromatic On/Off-button enabled	0 -> Button disabled; 1 -> Button enabled	1.00.025+
23	TempSet	Zone Temp. Setpoint	180 - 280 [1/10 °C]	1.00.025+
24	HumiSet	Zone Hum. Setpoint	19 -> No, 20 - 80 [%rH]	1.00.025+
26	HumiProp	Humidity proportional band	2 - 60 [%rH]	1.00.025+
27	SupplyProp	Supply air proportional band	10 - 300 [1/10 K]	1.00.025+
28	IntgReturn	Return air integration factor	59 -> No, 60 - 900 [sec]	1.00.025+
29	IntgSupply	Supply air integration factor	59 -> No, 60 - 900 [sec]	1.00.025+
30	HumiCtrl	Humidifier control	0 -> On-Off; 1 -> Proportional	1.00.025+
31	Override_HL	Override	0 -> normal; 1 -> Override	1.00.025+
32	Hum_Compen	Humidity compensation	0 -> No; 1 -> Yes	1.00.025+
33	ValveTimCW	Chilled water valve running time	30 - 500 [sec]	1.00.025+
34	ValveTimHW	Hot water valve running time	30 - 500 [sec]	1.00.025+
35	HwAndElHea	Simultaneous HW + el. Heating	0 -> No; 1 -> Yes	1.00.025+
36	HeatSteps	Heating steps	0; 1; 2; 3	1.00.025+
37	DehumTyp	Dehumidification enable	0 -> No; 1 -> Yes	1.00.025+
40	HumSteam	Humidifier steam output	0 -> No; 1 -> 30%; 2 -> 40%; 3 -> 50%; 4 -> 60%; 5 -> 70%; 6 -> 80%; 7 -> 90%; 8 -> 100%;	1.00.025+
41	UnitType	Unit type (single coil / double coil)	0 -> Single, 1 -> Double	1.00.025+
42	FanSpeedTy	Fan Speed setting	0->Low; 1->Medium; 2->High	1.00.025+
43	FanspeedLo	Fanspeed low	0 - 100 [%]	1.00.025+
44	FanspeedMe	Fanspeed medium	0 - 100 [%]	1.00.025+
45	FanspeedHi	Fanspeed high	0 - 100 [%]	1.00.025+
46	SupLim_Min	Minimum supply temperature	0 - 50 [°C]	1.00.025+
47	SupLim_Max	Maximum supply temperature	0 - 50 [°C]	1.00.025+
48	SupComFact	Supply air compensation factor	10 - 100 [1/10]	1.00.025+
49	Sup_DeadB	Supply air dead band	0 - 10 [K]	1.00.025+
50	OppFuncDel	Cooling-Heating delay	0 - 30 [min]	1.00.025+
51	SummCompAt	Summer compensation starts at	0 - 40 [°C]	1.00.025+
52	WintCompAt	Winter compensation starts at	0 - 40 [°C]	1.00.025+
53	SummMaxK	Max K (Summer)	0 - 10 [K]	1.00.025+
54	WintMaxK	Max K (Winter)	0 - 10 [K]	1.00.025+
55	SummFactor	Summer compensation factor	10 - 100 [1/10 K]	1.00.025+
56	WintFactor	Winter compensation factor	10 - 100 [1/10 K]	1.00.025+
57	OutdCompen	Outdoor compensation enabled	0 -> No; 1 -> Yes	1.00.025+
58	SleepOvTim	Override time	0 - 60 [min]	1.00.025+
59	AirRedu_EN	Air volume reduction enabled	0 -> No; 1 -> Yes	1.00.025+
60	AirGrA_Num	xTU Group A-NA	0 - 24	1.00.025+
61	AirGrB_Num	xTU Group B-NB	0 - 24	1.00.025+
62	AirGrC_Num	xTU Group C-NC	0 - 24	1.00.025+
63	AirGrD_Num	xTU Group D-ND	0 - 24	1.00.025+
64	AirGrA_Fac	xTU Group A-KPA	10 - 100 [1/10]	1.00.025+
65	AirGrC_Fac	xTU Group C-KPC	10 - 100 [1/10]	1.00.025+
66	AirGrB_Fac	xTU Group B-KPB	10 - 100 [1/10]	1.00.025+
67	AirGrD_Fac	xTU Group D-KPD	10 - 100 [1/10]	1.00.025+
68	Air_IntSpe	Speed at bus interruption	0 -> Low; 1 -> Med; 2 -> High	1.00.025+
69	HiTemp	High zone temperature	0 -> No; 1 - 99 [°C]	1.00.025+
70	LoTemp	Low zone temp./ Night set back	0 -> No; 1 - 99 [°C]	1.00.025+
71	HiHumi	High zone humidity	0 -> No; 1 - 99 [%rH]	1.00.025+
72	LoHumi	Low zone humidity	0 -> No; 1 - 99 [%rH]	1.00.025+
73	HiTempE	High supply temperature	0 -> No; 1 - 99 [°C]	1.00.025+
74	LoTempE	Low supply temperature	0 -> No; 1 - 99 [°C]	1.00.025+
77	AirflowWa	Low airflow warning at	0 - 99 [%]; 100 -> SWI	1.00.025+
78	FanWaAl	Fan-failure warning/alarm	0 -> Warning; 1 -> Alarm	1.00.025+

79	LiquiAl	Liquistat alarm selection	0 -> No; 1 -> Warning; 2 -> Alarm	1.00.025+
80	AverOrPeak	Night set back	0 -> Average; 1 -> Peak	1.00.025+
81	HourHW	Hot water working hours	0 - 32000 [h]	1.00.025+
82	HourCond	Fan working hours	0 - 32000 [h]	1.00.025+
83	HourCW	Chilled water working hours	0 - 32000 [h]	1.00.025+
84	HourHumi	Humidifier working hours	0 - 32000 [h]	1.00.025+
85	HourHeat	Heater 1 working hours	0 - 32000 [h]	1.00.025+
86	HourHeat2	Heater 2 working hours	0 - 32000 [h]	1.00.025+
87	HourDehum	Dehumidification working hours	0 - 32000 [h]	1.00.025+
88	HourCondMa	Fan working hours warning	0 - 32000 [h]	1.00.025+
89	HourHumiMa	Humidifier working hours warning	0 - 32000 [h]	1.00.025+
90	HourHeatMa	Heater 1 working hours warning	0 - 32000 [h]	1.00.025+
91	HourHeat2M	Heater 2 working hours warning	0 - 32000 [h]	1.00.025+
92	HourDehumM	Dehum working hours warning	0 - 32000 [h]	1.00.025+
93	HourCW_Ma	CW working hours warning	0 - 32000 [h]	1.00.025+
94	HourHW_Ma	Hot water working hours warning	0 - 32000 [h]	1.00.025+
102	Pri_RoomSe	Priority of PTC return sensor	0 - 100 [%]	1.00.025+
103	Pri_EEAP_T	Priority of sensor 1 temp.	0 - 100 [%]	1.00.025+
104	Pri_EEAP_H	Priority of sensor 1 hum.	0 - 100 [%]	1.00.025+
105	Pri_HT1_T	Priority of sensor 2 temp.	0 - 100 [%]	1.00.025+
106	Pri_HT2_T	Priority of xTU peak	0 - 100 [%]	1.00.025+
107	Pri_HT1_H	Priority of sensor 2 hum.	0 - 100 [%]	1.00.025+
108	Pri_XTU_T	Priority of xTU average	0 - 100 [%]	1.00.025+
109	Hum_DeadB	Humidity deadband	0 - 500 [1/10%rH]	1.00.025+
111	Hum_Enable	Humidifier enabled	0 -> No; 1 -> Yes	1.00.025+
112	T1_MtF_Hou	Hour of 1st timer set (std. timer)	0 - 23 [h]	1.00.025+
113	T2_MtF_Hou	Hour of 2nd timer set (std. timer)	0 - 23 [h]	1.00.025+
114	T3_MtF_Hou	Hour of 3rd timer set (std. timer)	0 - 23 [h]	1.00.025+
115	T4_MtF_Hou	Hour of 4th timer set (std. timer)	0 - 23 [h]	1.00.025+
116	T1_DS1_Hou	Hour of 1st timer set (exc. timer)	0 - 23 [h]	1.00.025+
117	T2_DS1_Hou	Hour of 2nd timer set (exc. timer)	0 - 23 [h]	1.00.025+
118	T3_DS1_Hou	Hour of 3rd timer set (exc. timer)	0 - 23 [h]	1.00.025+
119	T4_DS1_Hou	Hour of 4th timer set (exc. timer)	0 - 23 [h]	1.00.025+
120	T1_MtF_Min	Min. of 1st timer set (std. timer)	0 - 59 [min]	1.00.025+
121	T2_MtF_Min	Min. of 2nd timer set (std. timer)	0 - 59 [min]	1.00.025+
122	T3_MtF_Min	Min. of 3rd timer set (std. timer)	0 - 59 [min]	1.00.025+
123	T4_MtF_Min	Min. of 4th timer set (std. timer)	0 - 59 [min]	1.00.025+
124	T1_DS1_Min	Min. of 1st timer set (exc. timer)	0 - 59 [min]	1.00.025+
125	T2_DS1_Min	Min. of 2nd timer set (exc. timer)	0 - 59 [min]	1.00.025+
126	T3_DS1_Min	Min. of 3rd timer set (exc. timer)	0 - 59 [min]	1.00.025+
127	T4_DS1_Min	Min. of 4th timer set (exc. timer)	0 - 59 [min]	1.00.025+
128	T1_MtF_Spe	Fanspeed of 1st timer set (std. timer)	0 -> Off; 1 -> Low; 2 -> Med; 3 -> High	1.00.025+
129	T2_MtF_Spe	Fanspeed of 2nd timer set (std. timer)	0 -> Off; 1 -> Low; 2 -> Med; 3 -> High	1.00.025+
130	T3_MtF_Spe	Fanspeed of 3rd timer set (std. timer)	0 -> Off; 1 -> Low; 2 -> Med; 3 -> High	1.00.025+
131	T4_MtF_Spe	Fanspeed of 4th timer set (std. timer)	0 -> Off; 1 -> Low; 2 -> Med; 3 -> High	1.00.025+
132	T1_DS1_Spe	Fanspeed of 1st timer set (exc. timer)	0 -> Off; 1 -> Low; 2 -> Med; 3 -> High	1.00.025+
133	T2_DS1_Spe	Fanspeed of 2nd timer set (exc. timer)	0 -> Off; 1 -> Low; 2 -> Med; 3 -> High	1.00.025+
134	T3_DS1_Spe	Fanspeed of 3rd timer set (exc. timer)	0 -> Off; 1 -> Low; 2 -> Med; 3 -> High	1.00.025+
135	T4_DS1_Spe	Fanspeed of 4th timer set (exc. timer)	0 -> Off; 1 -> Low; 2 -> Med; 3 -> High	1.00.025+
136	T1_MtF_Mod	Mode of 1st timer set (std. timer)	0 -> Off; 1 -> On	1.00.025+
137	T2_MtF_Mod	Mode of 2nd timer set (std. timer)	0 -> Off; 1 -> On	1.00.025+
138	T3_MtF_Mod	Mode of 3rd timer set (std. timer)	0 -> Off; 1 -> On	1.00.025+
139	T4_MtF_Mod	Mode of 4th timer set (std. timer)	0 -> Off; 1 -> On	1.00.025+
140	T1_DS1_Mod	Mode of 1st timer set (exc. timer)	0 -> Off; 1 -> On	1.00.025+
141	T2_DS1_Mod	Mode of 2nd timer set (exc. timer)	0 -> Off; 1 -> On	1.00.025+
142	T3_DS1_Mod	Mode of 3rd timer set (exc. timer)	0 -> Off; 1 -> On	1.00.025+
143	T4_DS1_Mod	Mode of 4th timer set (exc. timer)	0 -> Off; 1 -> On	1.00.025+
144	T1_MtF_Set	Setpoint of 1st timer set (std. timer)	180 - 280 [1/10 °C]	1.00.025+
145	T2_MtF_Set	Setpoint of 2nd timer set (std. timer)	180 - 280 [1/10 °C]	1.00.025+
146	T3_MtF_Set	Setpoint of 3rd timer set (std. timer)	180 - 280 [1/10 °C]	1.00.025+
147	T4_MtF_Set	Setpoint of 4th timer set (std. timer)	180 - 280 [1/10 °C]	1.00.025+
148	T1_DS1_Set	Setpoint of 1st timer set (exc. timer)	180 - 280 [1/10 °C]	1.00.025+
149	T2_DS1_Set	Setpoint of 2nd timer set (exc. timer)	180 - 280 [1/10 °C]	1.00.025+
150	T3_DS1_Set	Setpoint of 3rd timer set (exc. timer)	180 - 280 [1/10 °C]	1.00.025+
151	T4_DS1_Set	Setpoint of 4th timer set (exc. timer)	180 - 280 [1/10 °C]	1.00.025+
152	Ti_DS1_Act	Exception days enable / disable	0 -> Disable; 1 -> Enable	1.00.025+
153	Ti_MtF_Act	Std. day settings enable / disable	0 -> Disable; 1 -> Enable	1.00.025+
154	Ti_MtF_Mon	Monday selected for std. timer	0 -> No; 1 -> Yes	1.00.025+
155	Ti_MtF_Tue	Tuesday selected for std. timer	0 -> No; 1 -> Yes	1.00.025+
156	Ti_MtF_Wed	Wednesday selected for std. timer	0 -> No; 1 -> Yes	1.00.025+
157	Ti_MtF_Thu	Thursday selected for std. timer	0 -> No; 1 -> Yes	1.00.025+
158	Ti_MtF_Fri	Friday selected for std. timer	0 -> No; 1 -> Yes	1.00.025+
159	Ti_MtF_Sat	Saturday selected for std. timer	0 -> No; 1 -> Yes	1.00.025+
160	Ti_MtF_Sun	Sunday selected for std. timer	0 -> No; 1 -> Yes	1.00.025+

161	Ti_DS1_Mon	Monday selected for exc. timer	0 -> No; 1 -> Yes	1.00.025+
162	Ti_DS1_Tue	Tuesday selected for exc. Timer	0 -> No; 1 -> Yes	1.00.025+
163	Ti_DS1_Wed	Wednesday selected for exc. Timer	0 -> No; 1 -> Yes	1.00.025+
164	Ti_DS1_Thu	Thursday selected for exc. Timer	0 -> No; 1 -> Yes	1.00.025+
165	Ti_DS1_Fri	Friday selected for exc. Timer	0 -> No; 1 -> Yes	1.00.025+
166	Ti_DS1_Sat	Saturday selected for exc. Timer	0 -> No; 1 -> Yes	1.00.025+
167	Ti_DS1_Sun	Sunday selected for exc. Timer	0 -> No; 1 -> Yes	1.00.025+
168	T1_YS1_Day	Day 1 setting yearly exception days	1 - 31	1.00.025+
169	T2_YS1_Day	Day 2 setting yearly exception days	1 - 31	1.00.025+
170	T3_YS1_Day	Day 3 setting yearly exception days	1 - 31	1.00.025+
171	T4_YS1_Day	Day 4 setting yearly exception days	1 - 31	1.00.025+
172	T1_YS1_Mon	Month 1 setting yearly exception days	1 - 12	1.00.025+
173	T2_YS1_Mon	Month 2 setting yearly exception days	1 - 12	1.00.025+
174	T3_YS1_Mon	Month 3 setting yearly exception days	1 - 12	1.00.025+
175	T4_YS1_Mon	Month 4 setting yearly exception days	1 - 12	1.00.025+
176	T4_YS1_Act	Yearly exceptions enable / disable	0 -> No; 1 -> Yes	1.00.025+
177	T1_YS2_Day	Day 5 setting yearly exception days	1 - 31	1.00.025+
178	T2_YS2_Day	Day 6 setting yearly exception days	1 - 31	1.00.025+
179	T3_YS2_Day	Day 7 setting yearly exception days	1 - 31	1.00.025+
180	T4_YS2_Day	Day 8 setting yearly exception days	1 - 31	1.00.025+
181	T1_YS2_Mon	Month 5 setting yearly exception days	1 - 12	1.00.025+
182	T2_YS2_Mon	Month 6 setting yearly exception days	1 - 12	1.00.025+
183	T3_YS2_Mon	Month 7 setting yearly exception days	1 - 12	1.00.025+
184	T4_YS2_Mon	Month 8 setting yearly exception days	1 - 12	1.00.025+
185	FatSetp_1	xTU 1 temp. Setpoint	180 - 280 [1/10 °C]	1.00.025+
186	FatSetp_2	xTU 2 temp. Setpoint	180 - 280 [1/10 °C]	1.00.025+
187	FatSetp_3	xTU 3 temp. Setpoint	180 - 280 [1/10 °C]	1.00.025+
188	FatSetp_4	xTU 4 temp. Setpoint	180 - 280 [1/10 °C]	1.00.025+
189	FatSetp_5	xTU 5 temp. Setpoint	180 - 280 [1/10 °C]	1.00.025+
190	FatSetp_6	xTU 6 temp. Setpoint	180 - 280 [1/10 °C]	1.00.025+
191	FatSetp_7	xTU 7 temp. Setpoint	180 - 280 [1/10 °C]	1.00.025+
192	FatSetp_8	xTU 8 temp. Setpoint	180 - 280 [1/10 °C]	1.00.025+
193	FatSetp_9	xTU 9 temp. Setpoint	180 - 280 [1/10 °C]	1.00.025+
194	FatSetp_10	xTU 10 temp. Setpoint	180 - 280 [1/10 °C]	1.00.025+
195	FatSetp_11	xTU 11 temp. Setpoint	180 - 280 [1/10 °C]	1.00.025+
196	FatSetp_12	xTU 12 temp. Setpoint	180 - 280 [1/10 °C]	1.00.025+
197	FatSetp_13	xTU 13 temp. Setpoint	180 - 280 [1/10 °C]	1.00.025+
198	FatSetp_14	xTU 14 temp. Setpoint	180 - 280 [1/10 °C]	1.00.025+
199	FatSetp_15	xTU 15 temp. Setpoint	180 - 280 [1/10 °C]	1.00.025+
200	FatSetp_16	xTU 16 temp. Setpoint	180 - 280 [1/10 °C]	1.00.025+
201	FatSetp_17	xTU 17 temp. Setpoint	180 - 280 [1/10 °C]	1.00.025+
202	FatSetp_18	xTU 18 temp. Setpoint	180 - 280 [1/10 °C]	1.00.025+
203	FatSetp_19	xTU 19 temp. Setpoint	180 - 280 [1/10 °C]	1.00.025+
204	FatSetp_20	xTU 20 temp. Setpoint	180 - 280 [1/10 °C]	1.00.025+
205	FatSetp_22	xTU 21 temp. Setpoint	180 - 280 [1/10 °C]	1.00.025+
206	FatSetp_21	xTU 22 temp. Setpoint	180 - 280 [1/10 °C]	1.00.025+
207	FatSetp_23	xTU 23 temp. Setpoint	180 - 280 [1/10 °C]	1.00.025+
208	FatSetp_24	xTU 24 temp. Setpoint	180 - 280 [1/10 °C]	1.00.025+
209	XtuSetpRan	xTU setpoint range	0 - 10 [°C]	1.00.025+
210	IgnoredXTU	Number of ignored xTUs	0 - 23	1.00.025+
211	XTU_Delay	xTU off delay	0 - 60 [min]	1.00.025+
212	Fat_MaNumb	Number of connected master xTUs	0 - 24	1.00.025+
213	FatFanSp1	xTU 1 Fanspeed	0 - 100 [%]	1.00.025+
214	FatFanSp2	xTU 2 Fanspeed	0 - 100 [%]	1.00.025+
215	FatFanSp3	xTU 3 Fanspeed	0 - 100 [%]	1.00.025+
216	FatFanSp4	xTU 4 Fanspeed	0 - 100 [%]	1.00.025+
217	FatFanSp5	xTU 5 Fanspeed	0 - 100 [%]	1.00.025+
218	FatFanSp6	xTU 6 Fanspeed	0 - 100 [%]	1.00.025+
219	FatFanSp7	xTU 7 Fanspeed	0 - 100 [%]	1.00.025+
220	FatFanSp8	xTU 8 Fanspeed	0 - 100 [%]	1.00.025+
221	FatFanSp9	xTU 9 Fanspeed	0 - 100 [%]	1.00.025+
222	FatFanSp10	xTU 10 Fanspeed	0 - 100 [%]	1.00.025+
223	FatFanSp11	xTU 11 Fanspeed	0 - 100 [%]	1.00.025+
224	FatFanSp12	xTU 12 Fanspeed	0 - 100 [%]	1.00.025+
225	FatFanSp13	xTU 13 Fanspeed	0 - 100 [%]	1.00.025+
226	FatFanSp14	xTU 14 Fanspeed	0 - 100 [%]	1.00.025+
227	FatFanSp15	xTU 15 Fanspeed	0 - 100 [%]	1.00.025+
228	FatFanSp16	xTU 16 Fanspeed	0 - 100 [%]	1.00.025+
229	FatFanSp17	xTU 17 Fanspeed	0 - 100 [%]	1.00.025+
230	FatFanSp18	xTU 18 Fanspeed	0 - 100 [%]	1.00.025+
231	FatFanSp19	xTU 19 Fanspeed	0 - 100 [%]	1.00.025+
232	FatFanSp20	xTU 20 Fanspeed	0 - 100 [%]	1.00.025+
233	FatFanSp21	xTU 21 Fanspeed	0 - 100 [%]	1.00.025+
234	FatFanSp22	xTU 22 Fanspeed	0 - 100 [%]	1.00.025+

235	FatFanSp23	xTU 23 Fanspeed	0 – 100 [%]	1.00.025+
236	FatFanSp24	xTU 24 Fanspeed	0 – 100 [%]	1.00.025+
237	FatIgno_1	xTU 1 ignore	0 -> Never; 1 -> Always; 2 -> Auto	1.00.025+
238	FatIgno_2	xTU 2 ignore	0 -> Never; 1 -> Always; 2 -> Auto	1.00.025+
239	FatIgno_3	xTU 3 ignore	0 -> Never; 1 -> Always; 2 -> Auto	1.00.025+
240	FatIgno_4	xTU 4 ignore	0 -> Never; 1 -> Always; 2 -> Auto	1.00.025+
241	FatIgno_5	xTU 5 ignore	0 -> Never; 1 -> Always; 2 -> Auto	1.00.025+
242	FatIgno_6	xTU 6 ignore	0 -> Never; 1 -> Always; 2 -> Auto	1.00.025+
243	FatIgno_7	xTU 7 ignore	0 -> Never; 1 -> Always; 2 -> Auto	1.00.025+
244	FatIgno_8	xTU 8 ignore	0 -> Never; 1 -> Always; 2 -> Auto	1.00.025+
245	FatIgno_9	xTU 9 ignore	0 -> Never; 1 -> Always; 2 -> Auto	1.00.025+
246	FatIgno_10	xTU 10 ignore	0 -> Never; 1 -> Always; 2 -> Auto	1.00.025+
247	FatIgno_11	xTU 11 ignore	0 -> Never; 1 -> Always; 2 -> Auto	1.00.025+
248	FatIgno_12	xTU 12 ignore	0 -> Never; 1 -> Always; 2 -> Auto	1.00.025+
249	FatIgno_13	xTU 13 ignore	0 -> Never; 1 -> Always; 2 -> Auto	1.00.025+
250	FatIgno_14	xTU 14 ignore	0 -> Never; 1 -> Always; 2 -> Auto	1.00.025+
251	FatIgno_15	xTU 15 ignore	0 -> Never; 1 -> Always; 2 -> Auto	1.00.025+
252	FatIgno_16	xTU 16 ignore	0 -> Never; 1 -> Always; 2 -> Auto	1.00.025+
253	FatIgno_17	xTU 17 ignore	0 -> Never; 1 -> Always; 2 -> Auto	1.00.025+
254	FatIgno_18	xTU 18 ignore	0 -> Never; 1 -> Always; 2 -> Auto	1.00.025+
255	FatIgno_19	xTU 19 ignore	0 -> Never; 1 -> Always; 2 -> Auto	1.00.025+
256	FatIgno_20	xTU 20 ignore	0 -> Never; 1 -> Always; 2 -> Auto	1.00.025+
257	FatIgno_21	xTU 21 ignore	0 -> Never; 1 -> Always; 2 -> Auto	1.00.025+
258	FatIgno_22	xTU 22 ignore	0 -> Never; 1 -> Always; 2 -> Auto	1.00.025+
259	FatIgno_23	xTU 23 ignore	0 -> Never; 1 -> Always; 2 -> Auto	1.00.025+
260	FatIgno_24	xTU 24 ignore	0 -> Never; 1 -> Always; 2 -> Auto	1.00.025+

### Status-Report-Acknowledge (Holding Register #1):

Read the document 'Hirolink for Modbus V X.XX - General Documentation' (X.XX is a placeholder for the current version of the Hirolink) for a description on how to use this data-point.

### Alarm-Status (Holding Register #3):

This item holds a value, which represents the current alarm-state of the Hiromatic and the single Microfaces.

Either a 'Alarm Acknowledge' - or a 'Alarm Reset' -command can be written to the Microface:

<p><b>2 Alarm Reset:</b> This command will reset all alarms, warnings and messages currently present on the Hiromatic or Microface. As a consequence alarms, warnings and messages that are inactive will disappear, will active alarms, warnings and messages will be reported again.</p>	<p><b>4 Alarm Acknowledge:</b> This command will acknowledge all alarms, warnings and messages present on the Hiromatic or Microface. As a consequence alarms, warnings and messages that were in an unacknowledged state will be acknowledged after the command.</p>
--	---

When read, the value corresponds to the following states:

<b>0</b> No alarm present	<b>11</b> Warning ackn. (active)	<b>23</b> Alarm not ackn. (active)
<b>1</b> Message ackn. (inactive)	<b>13</b> Warning not ackn.(inactive)	<b>25</b> Alarm and warning ackn. (inactive)
<b>3</b> Message ackn.(active)	<b>15</b> Warning not ackn. (active)	<b>27</b> Alarm and warning ackn. (active)
<b>5</b> Message not ackn. (inactive)	<b>17</b> Alarm ackn. (inactive)	<b>29</b> Alarm and warning not ackn. (inactive)
<b>7</b> Message not ackn.(active)	<b>19</b> Alarm ackn. (active)	<b>31</b> Alarm and warning not ackn. (active)
<b>9</b> Warning ackn.(inactive)	<b>21</b> Alarm not ackn. (inactive)	

The terms 'acknowledged' and 'not acknowledged' define, if the reset-push-button on the Hiromatic has been pressed once in order to silence the buzzer or if the command 'Alarm Acknowledge' has been performed.

The terms 'active' and 'inactive' define, if the alarm, warning or message is still active, which means that after performing a alarm-reset (either by sending the appropriate command via the Modbus-network or by pressing the reset-push-button on the Hiromatic a second time) the alarm or warning will be reported again.

### 3.4 Input-Register

Register #	Hironet-Variable	Usage	Range; Unit	SW-Version
1	-	Event-ID	ID identifying the event	1.00.025+
2	-	Controller-ID	Controller-ID, where the event occurred	1.00.025+
3	-	Minute	Minute, when event occurred	1.00.025+
4	-	Hour	Hour, when event occurred	1.00.025+
5	-	Date	Date, when event occurred	1.00.025+
6	-	Event-type	0 -> message; 1 -> warning; 2 -> alarm; 3 and 4 -> reset	1.00.025+
7	HumiSet_ac	Actual humidity setpoint	19 -> No, 20 - 80 [%rH]	1.00.025+
8	TempSet_ac	Actual zone setpoint	180 - 280 [1/10 °C]	1.00.025+
9	UnitAlarm	Unit Alarm	See explanation below	1.00.025+
10	SingStatDi	Unit Status	See explanation below	1.00.025+
11	Sup_Set_ac	Supply air setpoint	0 - 500; [1/10 °C]	1.00.025+
12	AnaOutRam1	Analog output 1	0 - 100 [%]	1.00.025+
13	AnaOutRam2	Analog output 2	0 - 100 [%]	1.00.025+
14	LocTemp	Zone temperature	0 - 500; [1/10 °C]	1.00.025+
15	AMB_Temp	Actual outdoor temperature	-250 - 1000; [1/10 °C]	1.00.025+
16	HT21	xTU peak temperature	0 - 500; [1/10 °C]	1.00.025+
17	HT_Humi	Zone humidity	200 - 800; [%rH]	1.00.025+
18	SupplyTemp	PTC Supply air temperature	0 - 500; [1/10 °C]	1.00.025+
19	EEAPTtemp	Sensor 1 temperature	0 - 500; [1/10 °C]	1.00.025+
20	EEAPHumi	Sensor 1 humidity	200 - 800; [%rH]	1.00.025+
21	HT11	Sensor 2 temperature	0 - 500; [1/10 °C]	1.00.025+
22	HT12	Sensor 2 humidity	200 - 800; [%rH]	1.00.025+
23	Room_Temp	PTC Return air temperature	-250 - 1000; [1/10 °C]	1.00.025+
24	ManHumi	Humidifier	0 -> Off; 1 -> On	1.00.025+
25	ManFan	Fan	0 -> Off; 1 -> On	1.00.025+
26	ManDrain	Humidifier drain	0 -> Off; 1 -> On	1.00.025+
27	ManHeat1	Electrical heater 1	0 -> Off; 1 -> On	1.00.025+
29	ManDehum	Dehumidification	0 -> Off; 1 -> On	1.00.025+
30	ManAl_Rel	Status Alarm relay	0 -> Alarm; 1 -> OK	1.00.025+
31	Airflow	Airflow sensor	0 - 100 [%]	1.00.025+
32	LiquiSen	Liquistat Sensor	0 - 200 [1/100V]	1.00.025+
33	HCurr	Humidifier current	0 - 300 [1/10A]	1.00.025+
34	InUSR	User input 1	0->Inactive, 1->Active	1.00.025+
35	InUSR2	User input 2 (LSI)	0->Inactive, 1->Active	1.00.025+
36	InTSR	Heater safety	0->Inactive, 1->Warning	1.00.025+
37	InCF	Clogged filters	0->Inactive, 1->Warning	1.00.025+
38	InREM	Remote input	0->On, 1->Off	1.00.025+
39	InLSI	LSI input	0->Inactive, 1->Active	1.00.025+
40	InFire	Fire alarm	0->Inactive, 1->Alarm	1.00.025+
41	InHwOK	HW OK	0->Inactive, 1->OK	1.00.025+
42	Bara_Cool	Cooling	0 - 100 [%]	1.00.025+
43	Bara_DeH	Dehumidification	0 - 100 [%]	1.00.025+
44	Bara_HW	Hot water	0 - 100 [%]	1.00.025+
45	Bara_Heat	Heating	0 - 100 [%]	1.00.025+
47	Nom_Curr	Nominal current	0 - 300 [1/10A]	1.00.025+
49	Ramp_Fan	Fan ramp	0 - 100 [%]	1.00.025+
52	Ramp_CW_Va	Chilled water valve position	0 - 100 [%]	1.00.025+
53	Ramp_HW_Va	Hot water valve position	0 - 100 [%]	1.00.025+
54	Fat_Te_11	xTU 1 room temperature	0 - 500; [1/10 °C]	1.00.025+
55	Fat_Te_21	xTU 2 room temperature	0 - 500; [1/10 °C]	1.00.025+
56	Fat_Te_31	xTU 3 room temperature	0 - 500; [1/10 °C]	1.00.025+
57	Fat_Te_41	xTU 4 room temperature	0 - 500; [1/10 °C]	1.00.025+
58	Fat_Te_51	xTU 5 room temperature	0 - 500; [1/10 °C]	1.00.025+
59	Fat_Te_61	xTU 6 room temperature	0 - 500; [1/10 °C]	1.00.025+
60	Fat_Te_71	xTU 7 room temperature	0 - 500; [1/10 °C]	1.00.025+
61	Fat_Te_81	xTU 8 room temperature	0 - 500; [1/10 °C]	1.00.025+
62	Fat_Te_91	xTU 9 room temperature	0 - 500; [1/10 °C]	1.00.025+
63	Fat_Te_101	xTU 10 room temperature	0 - 500; [1/10 °C]	1.00.025+
64	Fat_Te_111	xTU 11 room temperature	0 - 500; [1/10 °C]	1.00.025+
65	Fat_Te_121	xTU 12 room temperature	0 - 500; [1/10 °C]	1.00.025+
66	Fat_Te_131	xTU 13 room temperature	0 - 500; [1/10 °C]	1.00.025+
67	Fat_Te_141	xTU 14 room temperature	0 - 500; [1/10 °C]	1.00.025+
68	Fat_Te_151	xTU 15 room temperature	0 - 500; [1/10 °C]	1.00.025+
69	Fat_Te_161	xTU 16 room temperature	0 - 500; [1/10 °C]	1.00.025+
70	Fat_Te_171	xTU 17 room temperature	0 - 500; [1/10 °C]	1.00.025+



71	Fat_Te_181	xTU 18 room temperature	0 - 500; [1/10 °C]	1.00.025+
72	Fat_Te_191	xTU 19 room temperature	0 - 500; [1/10 °C]	1.00.025+
73	Fat_Te_201	xTU 20 room temperature	0 - 500; [1/10 °C]	1.00.025+
74	Fat_Te_211	xTU 21 room temperature	0 - 500; [1/10 °C]	1.00.025+
75	Fat_Te_221	xTU 22 room temperature	0 - 500; [1/10 °C]	1.00.025+
76	Fat_Te_231	xTU 23 room temperature	0 - 500; [1/10 °C]	1.00.025+
77	Fat_Te_241	xTU 24 room temperature	0 - 500; [1/10 °C]	1.00.025+
102	Fat_Te_12	xTU 1 underfloor temperature	0 - 500; [1/10 °C]	1.00.025+
103	Fat_Te_22	xTU 2 underfloor temperature	0 - 500; [1/10 °C]	1.00.025+
104	Fat_Te_32	xTU 3 underfloor temperature	0 - 500; [1/10 °C]	1.00.025+
105	Fat_Te_42	xTU 4 underfloor temperature	0 - 500; [1/10 °C]	1.00.025+
106	Fat_Te_52	xTU 5 underfloor temperature	0 - 500; [1/10 °C]	1.00.025+
107	Fat_Te_62	xTU 6 underfloor temperature	0 - 500; [1/10 °C]	1.00.025+
108	Fat_Te_72	xTU 7 underfloor temperature	0 - 500; [1/10 °C]	1.00.025+
109	Fat_Te_82	xTU 8 underfloor temperature	0 - 500; [1/10 °C]	1.00.025+
110	Fat_Te_92	xTU 9 underfloor temperature	0 - 500; [1/10 °C]	1.00.025+
111	Fat_Te_102	xTU 10 underfloor temperature	0 - 500; [1/10 °C]	1.00.025+
112	Fat_Te_112	xTU 11 underfloor temperature	0 - 500; [1/10 °C]	1.00.025+
113	Fat_Te_122	xTU 12 underfloor temperature	0 - 500; [1/10 °C]	1.00.025+
114	Fat_Te_132	xTU 13 underfloor temperature	0 - 500; [1/10 °C]	1.00.025+
115	Fat_Te_142	xTU 14 underfloor temperature	0 - 500; [1/10 °C]	1.00.025+
116	Fat_Te_152	xTU 15 underfloor temperature	0 - 500; [1/10 °C]	1.00.025+
117	Fat_Te_162	xTU 16 underfloor temperature	0 - 500; [1/10 °C]	1.00.025+
118	Fat_Te_172	xTU 17 underfloor temperature	0 - 500; [1/10 °C]	1.00.025+
119	Fat_Te_182	xTU 18 underfloor temperature	0 - 500; [1/10 °C]	1.00.025+
120	Fat_Te_192	xTU 19 underfloor temperature	0 - 500; [1/10 °C]	1.00.025+
121	Fat_Te_202	xTU 20 underfloor temperature	0 - 500; [1/10 °C]	1.00.025+
122	Fat_Te_212	xTU 21 underfloor temperature	0 - 500; [1/10 °C]	1.00.025+
123	Fat_Te_222	xTU 22 underfloor temperature	0 - 500; [1/10 °C]	1.00.025+
124	Fat_Te_232	xTU 23 underfloor temperature	0 - 500; [1/10 °C]	1.00.025+
125	Fat_Te_242	xTU 24 underfloor temperature	0 - 500; [1/10 °C]	1.00.025+
126	XTUs_Temp	xTU average temperature	0 - 500; [1/10 °C]	1.00.025+

### Status-Report-Block (Input Register #1 - #6):

Read the document 'Hirolink for Modbus V X.XX - General Documentation' (X.XX is a placeholder for the current version of the Hirolink) for a description on how to use these data-points.

### Unit Alarm (Input Register #9):

This item holds a value, which represents the current alarm-state of the whole system. This alarm-state is calculated from the single alarm-states of each Microface and holds the highest of those alarm-states. The single alarm-states can be read using the appropriate Holding Registers.

The values correspond to the following states:

<b>0</b> No alarm present	<b>11</b> Warning ackn. (active)	<b>23</b> Alarm not ackn. (active)
<b>1</b> Message ackn. (inactive)	<b>13</b> Warning not ackn.(inactive)	<b>25</b> Alarm and warning ackn. (inactive)
<b>3</b> Message ackn.(active)	<b>15</b> Warning not ackn. (active)	<b>27</b> Alarm and warning ackn. (active)
<b>5</b> Message not ackn. (inactive)	<b>17</b> Alarm ackn. (inactive)	<b>29</b> Alarm and warning not ackn. (inactive)
<b>7</b> Message not ackn.(active)	<b>19</b> Alarm ackn. (active)	<b>31</b> Alarm and warning not ackn. (active)
<b>9</b> Warning ackn.(inactive)	<b>21</b> Alarm not ackn. (inactive)	

The terms 'acknowledged' and 'not acknowledged' define, if the reset-push-button on the Hiromatic has been pressed once in order to silence the buzzer or if the command 'Alarm Acknowledge' has been performed.

The terms 'active' and 'inactive' define, if the alarm, warning or message is still active, which means that after performing a alarm-reset (either by sending the appropriate command via the Modbus-network or by pressing the reset-push-button on the Hiromatic a second time) the alarm or warning will be reported again.

### Unit Status (Input Register #10):

This item holds a value, which represents the current system-state of the unit. The values correspond to the following states:

<b>0</b> Alarm Off	<b>6</b> Timer Off	<b>12</b> BMS Off
<b>1</b> Manual	<b>7</b> Unit On	<b>13</b> Set Back
<b>2</b> Local Off	<b>8</b> Warning On	<b>14</b> Recovery Mode
<b>3</b> Unit Off	<b>9</b> Alarm On	<b>15</b> Override
<b>4</b> Alarm Standby	<b>10</b> Timer ON	
<b>5</b> Standby	<b>11</b> Remote Off	

## 3.5 Events

### 3.5.1 Event-List

#### **IMPORTANT:**

Read the document 'Hirolink for Modbus V X.XX - General Documentation' (X.XX is a placeholder for the current version of the Hirolink) for a detailed description on how to use these data-points.

In the following list you can see all Events and Event-IDs available for CAM:

Event-ID	Event-Description	Event-Type	SW-Version
0	GENERAL ALARM	RESET, ACKNOWLEDGE	1.00.025+
5	ELECTRICAL HEATERS OVERHEATED	WARNING	1.00.025+
6	FAN FAILURE	WARNING	1.00.025+
7	FAN FAILURE	ALARM	1.00.025+
8	CLOGGED FILTERS	WARNING	1.00.025+
9	WATER LEAKAGE	WARNING	1.00.025+
10	WATER LEAKAGE	ALARM	1.00.025+
11	USER INPUT 1 TRIGGERED	WARNING	1.00.025+
12	USER INPUT 1 TRIGGERED	ALARM	1.00.025+
13	HUMIDIFIER FAILURE	WARNING	1.00.025+
14	HUMIDIFIER HIGH CURRENT	WARNING	1.00.025+
15	HUMIDIFIER FAILURE	WARNING	1.00.025+
16	HUMIDIFIER FAILURE	WARNING	1.00.025+
17	HUMIDIFIER CYLINDER WORN	WARNING	1.00.025+
18	HIGH ZONE TEMPERATURE	WARNING	1.00.025+
19	LOW ZONE TEMPERATURE	WARNING	1.00.025+
20	HIGH ZONE HUMIDITY	WARNING	1.00.025+
21	LOW ZONE HUMIDITY	WARNING	1.00.025+
22	HIGH SUPPLY TEMPERATURE	WARNING	1.00.025+
23	LOW SUPPLY TEMPERATURE	WARNING	1.00.025+
26	CONDITIONER WORKING HOURS EXCEEDED	WARNING	1.00.025+
28	HUMIDIFIER WORKING HOURS EXCEEDED	WARNING	1.00.025+
29	PTC SENSOR FAILURE	WARNING	1.00.025+
30	ROOM SENSOR FAILURE	WARNING	1.00.025+
31	ROOM SENSOR FAILURE	ALARM	1.00.025+
32	T+H SENSOR 2 FAILURE	WARNING	1.00.025+
33	WATER PRESENCE SENSOR FAILURE	WARNING	1.00.025+
34	NETWORK FAILURE	WARNING	1.00.025+
35	OUT OF MEMORY	WARNING	1.00.025+
36	UNIT ON	MESSAGE	1.00.025+
37	UNIT OFF	MESSAGE	1.00.025+
38	TIMER MODE	MESSAGE	1.00.025+
39	STANDBY MODE	MESSAGE	1.00.025+
40	POWER ON UNIT LOGIN	MESSAGE	1.00.025+
41	POWER OFF	MESSAGE	1.00.025+
42	Unit 1 disconnected	WARNING	1.00.025+
43	Unit 2 disconnected	WARNING	1.00.025+
44	Unit 3 disconnected	WARNING	1.00.025+
45	Unit 4 disconnected	WARNING	1.00.025+
46	Unit 5 disconnected	WARNING	1.00.025+
47	Unit 6 disconnected	WARNING	1.00.025+
48	Unit 7 disconnected	WARNING	1.00.025+
49	Unit 8 disconnected	WARNING	1.00.025+
50	Unit 9 disconnected	WARNING	1.00.025+
51	Unit 10 disconnected	WARNING	1.00.025+
52	Unit 11 disconnected	WARNING	1.00.025+
53	Unit 12 disconnected	WARNING	1.00.025+
54	Unit 13 disconnected	WARNING	1.00.025+
55	Unit 14 disconnected	WARNING	1.00.025+
56	Unit 15 disconnected	WARNING	1.00.025+
57	Unit 16 disconnected	WARNING	1.00.025+
61	OUTDOOR TEMP. SENSOR FAILURE	WARNING	1.00.025+
64	ON-OFF BY HIROMATIC NOT ENABLED	MESSAGE	1.00.025+

68	USER INPUT 2 TRIGGERED	WARNING	1.00.025+
69	USER INPUT 2 TRIGGERED	ALARM	1.00.025+
70	NO CONNECTION TO UNIT 1	WARNING	1.00.025+
73	FIRE ALARM	ALARM	1.00.025+
74	OUT OF MEMORY	WARNING	1.00.025+
77	NETWORK PING	WARNING	1.00.025+
85	UNIT SYNCHRONISATION	MESSAGE	1.00.025+
90	AIRFLOW DEVICE NOT READY, PLS. CHECK	WARNING	1.00.025+
91	CW WORKING HOURS EXCEEDED	WARNING	1.00.025+
92	HW WORKING HOURS EXCEEDED	WARNING	1.00.025+
93	HEATER 1 WORKING HOURS EXCEEDED	WARNING	1.00.025+
94	HEATER 2 WORKING HOURS EXCEEDED	WARNING	1.00.025+
95	DEHUMIDIFICATION WORKING HOURS EXCEEDED	WARNING	1.00.025+
98	LOC OFF	MESSAGE	1.00.025+
99	REM OFF	MESSAGE	1.00.025+
100	CONNECTED	MESSAGE	1.00.025+
101	NOT CONNECTED	MESSAGE	1.00.025+
102	TIMER OFF	MESSAGE	1.00.025+
103	BMS OFF	MESSAGE	1.00.025+
104	RECOVERY	MESSAGE	1.00.025+
105	MANUAL	MESSAGE	1.00.025+
106	OVERRIDE	MESSAGE	1.00.025+
107	SETBACK	MESSAGE	1.00.025+

## 4. Document-Changes

This appendix contains all changes that have been applied to this document up to the current version:

### 1. Release V 1.00

This is the first released version.

### 2. Release V 1.01

The HR12 has been removed because does not work for this application.  
The HR42 has been added.

## Connectivity



*The evolution*

# Hirolink for Modbus

(15) Items for MOBILE (ENG) (Powerface) Units V 1.60+

**Service Manual**

**English**

28/03/06 Release 1.00E

## **CONTENTS**

<b>1.</b>	<b>INTRODUCTION .....</b>	<b>3</b>
<b>2.</b>	<b>COMPATIBILITY-LIST .....</b>	<b>3</b>
<b>3.</b>	<b>ITEMS FOR HIROMATIC-TYPE ENG .....</b>	<b>4</b>
3.1	COILS .....	4
3.2	INPUT-STATUS .....	4
3.3	HOLDING REGISTER .....	5
3.4	INPUT-REGISTER .....	8
3.5	EVENTS .....	11
3.5.1	<i>Event-Registers</i> .....	11
3.5.2	<i>Event-List</i> .....	13
<b>A.</b>	<b>DOCUMENT-CHANGES .....</b>	<b>15</b>

## 1. Introduction

This document contains a description of all data-points that are available via the 'Hirolink for Modbus' from this type of air-conditioner.

### **IMPORTANT:**

It is vital to the correct integration of the Hirolink into a Modbus-network, that you have read and understood the topics described in the document 'Hirolink for Modbus V X.XX - General Documentation' (X.XX is a placeholder for the current version of the Hirolink). So, if you haven't read this document until now, read it first.

## 2. Compatibility-List

Before connecting a Hiromatic to the Modbus-Hirolink you must check, if the Hiromatic-software-version is compatible with this version of the Hirolink.

You can do this by checking the labels on the eproms, which are inserted into the Hiromatic and the Powerface. The eprom inserted in the Hiromatic must be called ENG+ Version-Number (e.g. ENG160) and the one inserted in the Powerface must be called ENM + Version-Number (e.g. ENM160).

To make sure that the label on the eproms is correct, you should also check the version-information, that the Hiromatic displays shortly after start-up. This information should look similar to the following illustration:

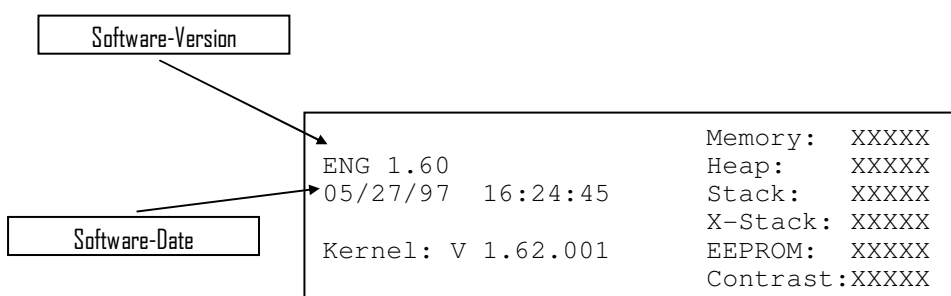

The important information in this window is only the software-version and the software-date (note that the date-format is mm/dd/yy). Make sure that the software-version installed in your installation matches one of the compatible versions listed below:

<b>Version</b>	<b>Date</b>
1.60.xxx	---

### 3. Items for Hiromatic-Type ENG

According to the Modbus-protocol-specifications the values and parameters provided by the Hiromatic are represented in 4 groups:

- Coils: Used for changeable, digital values
- Inputs: Used for not changeable, digital values
- Holding Registers: Used for changeable, analog values
- Input Registers: Used for not changeable, analog values

This Hirolink can be compatible with more than one version of this Hiromatic-type and it is possible that there have been extensions in the number of available items from one version to the next.

Therefore the column 'SW-Version' contained in the following lists provides information about the availability of each item depending on the Hiromatic-software-version. For example a entry like '1.15+' means, that this item is available from Hiromatics with software-version 1.15 and higher.

#### **IMPORTANT:**

The available data-points shown in the following chapters are numbered starting from 1, according to the Modbus-Protocol-Specification. Still some BMS start numbering the data-points from 0.

So, in case that the BMS you are using starts numbering from 0, you have to decrease the listed numbers by 1.

#### **3.1 Coils**

Not used on this Hiromatic-type.

#### **3.2 Input-Status**

Not used on this Hiromatic-type.

### 3.3 Holding Register

#### IMPORTANT NOTE:

The Hirolink for Modbus for Powerface has a considerable amount of addresses RESERVED! I.e. : Register 9 till 18, 25 till 34, etc. For this reason they have to be considered INVALID !

Register #	Usage	Range; Unit	SW-Version
1	Status-Report-Acknowledge	See explanation below	1.60+
2	HM-System On/Off	0 -> Hiromatic System Off; 1 -> Hiromatic System On	1.60+
3 - 8	Single Alarm-Status (POW 1 - 6)	See explanation below	1.60+
19-24	Single Unit System On/Off (POW 1 - 6)	0 -> Single Unit System Off; 1 -> Single Unit System On	1.60+
35-40	Conditioner Working Hours (POW 1 - 6)	0 - 32000; [h]	1.60+
51-56	Compressor 1 Working Hours (POW 1 - 6)	0 - 32000; [h]	1.60+
67-72	Compressor 2 Working Hours (POW 1 - 6)	0 - 32000; [h]	1.60+
83-88	Heater Working Hours (POW 1 - 6)	0 - 32000; [h]	1.60+
99-104	Freecooling Working Hours (POW 1 - 6)	0 - 32000; [h]	1.60+
115-120	Humidifier Working Hours (POW 1 - 6)	0 - 32000; [h]	1.60+
131-136	Low Pressure Delay Time (POW 1 - 6)	0 - 5; [min]	1.60+
147-152	High Temperature Warning (POW 1 - 6)	0 -> No, 1 - 99; [%RH]	1.60+
163-168	Low Temperature Warning (POW 1 - 6)	0 -> No, 1 - 99; [%RH]	1.60+
179-184	High Humidity Warning (POW 1 - 6)	0 -> No, 1 - 99; [°C]	1.60+
195-200	Low Humidity Warning (POW 1 - 6)	0 -> No, 1 - 99; [°C]	1.60+
211-216	High Temperature Alarm (POW 1 - 6)	0 -> No, 1 - 99; [%RH]	1.60+
227-232	Low Temperature Alarm (POW 1 - 6)	0 -> No, 1 - 99; [%RH]	1.60+
243-248	High Humidity Alarm (POW 1 - 6)	0 -> No, 1 - 99; [°C]	1.60+
259-264	Low Humidity Alarm (POW 1 - 6)	0 -> No, 1 - 99; [°C]	1.60+
275	Number of Standby Units	0 - 16	1.60+
276-290	not used		
291-296	Humidity Integral Factor (POW 1 - 6)	4 -> No, 5 - 15; [min]	1.60+
307-312	Temperature Integral Factor (POW 1 - 6)	4 -> No, 5 - 15; [min]	1.60+
323-328	Humidity Proportional Band (POW 1 - 6)	5 - 20; [%RH]	1.60+
339-344	Temperature Proportional Band (POW 1 - 6)	10 - 100; [1/10 K]	1.60+
355	Shared Parameters	0 -> No, 1 -> Yes	1.60+
356-370	not used		
371-376	Fanspeed (POW 1 - 6)	29 -> No, 30 - 100; [%]	1.60+
387-392	Supply Air Setpoint (POW 1 - 6)	5 - 25; [°C]	1.60+
403-408	Room Humidity Setpoint (POW 1 - 6)	19 -> No; 20 - 80; [%RH]	1.60+
419-424	Room Temperature Setpoint 1 (POW 1 - 6)	50 - 400; [1/10 °C]	1.60+
435-440	Room Temperature Setpoint 2 (POW 1 - 6)	14 -> No, 15 - 40; [1/10 °C]	1.60+
451-456	Stop Freecooling at (POW 1 - 6)	0 -> No, 1 - 25; [K]	1.60+
467-472	Freecooling Difference between room and glycol temperature (POW 1 - 6)	0 -> No, 1 - 25; [K]	1.60+
483-488	Freecooling Difference between room and ambient temperature (POW 1 - 6)	0 -> No, 1 -> EFC, 1 - 25; [K]	1.60+



### Status-Report-Acknowledge (Holding Register #1):

Read the document 'Hirolink for Modbus V X.XX - General Documentation' (X.XX is a placeholder for the current version of the Hirolink) for a description on how to use this data-point.

### Single Alarm-Status (Holding Registers #3 - #8):

This item holds a value which represents the current alarm-state of single Powerface.

It can be written to in order to perform either a 'Alarm Acknowledge'- or a 'Alarm Reset'-command on a single Powerface:

#### 2 .. Alarm Reset:

This command will reset all alarms, warnings and messages currently present on a Powerface. As a consequence alarms, warnings and messages that are inactive will disappear, will active alarms, warnings and messages will be reported again.

#### 4 .. Alarm Acknowledge:

This command will acknowledge all alarms, warnings and messages present on a Powerface. As a consequence alarms, warnings and messages that were in an unacknowledged state will be acknowledged after the command.

When read, the value corresponds to the following states:

0 .. No alarm present

1 .. Message acknowledged (inactive)

3 .. Message acknowledged (active)

5 .. Message not acknowledged (inactive)

7 .. Message not acknowledged (active)

9 .. Warning acknowledged (inactive)

11.. Warning acknowledged (active)

13.. Warning not acknowledged (inactive)

15.. Warning not acknowledged (active)

17.. Alarm acknowledged (inactive)

19.. Alarm acknowledged (active)

21...Alarm not acknowledged (inactive)

23.. Alarm not acknowledged (active)

25.. Alarm and warning acknowledged (inactive)

27.. Alarm and warning acknowledged (active)

29.. Alarm and warning not acknowledged (inactive)

31.. Alarm and warning not acknowledged (active)

The terms 'acknowledged' and 'not acknowledged' define, if the reset-push-button on the Hiromatic has been pressed once in order to silence the buzzer or if the command 'Alarm Acknowledge' has been performed.

The terms 'active' and 'inactive' define, if the alarm, warning or message is still active, which means that after performing a alarm-reset (either by sending the appropriate command via the Modbus-network or by pressing the reset-push-button on the Hiromatic a second time) the alarm or warning will be reported again.

**NOTE:**

Although you can read the alarm-state of the whole system (see 3.4 'Input-Register'), it is not possible to issue a 'Alarm Acknowledge'- or 'Alarm Reset'-command for the whole system. Instead you have to issue these commands for each Powerface separately.

### 3.4 Input-Register

#### IMPORTANT NOTE:

The Hirolink for Modbus for Powerface has a considerable amount of addresses RESERVED! I.e. : Register 9 till 18, 25 till 34, etc. For this reason they have to be considered INVALID !

Register #	Usage	Range; Unit	SW-Version
1	Event-ID	ID identifying the event	1.60+
2	Controller-ID	Controller-ID, where the event occurred	1.60+
3	Minute	Minute, when event occurred	1.60+
4	Hour	Hour, when event occurred	1.60+
5	Date	Date, when event occurred	1.60+
6	Event-Type	0 -> message, 1 -> warning, 2 -> alarm, 3 and 4 -> reset	1.60+
7	System Alarm	See explanation below	1.60+
8	System Status	See explanation below	1.60+
9-14	Single Status (per Unit) (POW 1 - 6)	See explanation below	1.60+
25-30	Status Fan (POW 1 - 6)	0 -> Off, 1 -> On	1.60+
41	Shared Room Temperature	-300 - 1000; [1/10 °C]	1.60+
42-56	not used		
57	Shared Room Humidity	0 - 100; [%RH]	
58-72	not used		1.60+
73	Shared Ambient Temperature	-300 - 1000; [1/10 °C]	
74-88	not used		1.60+
89	Shared Cooling Percentage	0 - 100; [%]	1.60+
90-104	not used		
105	Shared Heating Percentage	0 - 100; [%]	1.60+
106-120	not used		
121	Shared Freecooling Percentage	0 - 100; [%]	1.60+
122-136	not used		
137	Shared Humidification Percentage	0 - 100; [%]	1.60+
138-152	not used		
153	Shared Dehumidification Percentage	0 - 100; [%]	1.60+
154-168	not used		
169	Shared Service Percentage	0 - 100; [%]	1.60+
170-184	not used		
185-190	Room Temperature (POW 1 - 6)	-300 - 1000; [1/10 °C]	1.60+
201-206	Room Humidity (POW 1 - 6)	0-1000; [1/10 %RH]	1.60+
217-222	Ambient Temperature (POW 1 - 6)	-300 - 1000; [1/10 °C]	1.60+
233-238	Actual Temperature Setpoint (POW 1 - 6)	50 - 400; [1/10 °C]	1.60+
249-254	Actual Humidity Setpoint (POW 1 - 6)	50 - 400; [1/10 °C]	1.60+
265-270	Cooling Percentage	0 - 100; [%]	1.60+
281-286	Heating Percentage	0 - 100; [%]	1.60+
297-302	Freecooling Percentage	0 - 100; [%]	1.60+
313-318	Humidification Percentage	0 - 100; [%]	1.60+
329-334	Dehumidification Percentage	0 - 100; [%]	1.60+
345-350	Service Percentage	0 - 100; [%]	1.60+
361-366	High pressure Circuit 1	-1000 - 5000; [1/100 bar]	1.60+
377-382	Low pressure Circuit 1	-1000 - 5000; [1/100 bar]	1.60+
393-398	Condensing Temperature Circuit 1	-1000 - 1000; [1/10 °C]	1.60+

409-414	Evaporating Temperature Circuit 1	-1000 - 1000; [1/10 °C]	1.60+
425-430	Discharge Temperature Circuit 1	-1000 - 1000; [1/10 °C]	1.60+
441-446	Suction Temperature Circuit 1	-1000 - 1000; [1/10 °C]	1.60+
457-462	Liquid Temperature Circuit 1	-1000 - 1000; [1/10 °C]	1.60+
473-478	Superheat Circuit 1	0 - 100; [%]	1.60+
489-494	Sub cooling Circuit 1	0 - 100; [%]	1.60+
505-510	High pressure Circuit 2	-1000 - 5000; [1/100 bar]	1.60+
521-516	Low pressure Circuit 2	-1000 - 5000; [1/100 bar]	1.60+
537-542	Condensing Temperature Circuit 2	-1000 - 1000; [1/10 °C]	1.60+
553-558	Evaporating Temperature Circuit 2	-1000 - 1000; [1/10 °C]	1.60+
569-574	Discharge Temperature Circuit 2	-1000 - 1000; [1/10 °C]	1.60+
585-590	Suction Temperature Circuit 2	-1000 - 1000; [1/10 °C]	1.60+
601-606	Liquid Temperature Circuit 2	-1000 - 1000; [1/10 °C]	1.60+
617-622	Superheat Circuit 2	0 - 100; [%]	1.60+
633-638	Sub cooling Circuit 2	0 - 100; [%]	1.60+

### Status-Report-Block (Input Register #1 - #6):

Read the document 'Hirolink for Modbus V X.XX - General Documentation' (X.XX is a placeholder for the current version of the Hirolink) for a description on how to use these data-points.

### System-Alarm (Input Register #7):

This item holds a value, which represents the current alarm-state of the whole system. This alarm-state is calculated from the single alarm-states of each Powerface and holds the highest of those alarm-states. The single alarm-states can be read using the appropriate Holding Registers (see 3.3 'Holding Register').

The values correspond to the following states:

- 0 .. No alarm present
- 1 .. Message acknowledged (inactive)
- 3 .. Message acknowledged (active)
- 5 .. Message not acknowledged (inactive)
- 7 .. Message not acknowledged (active)
  
- 9 .. Warning acknowledged (inactive)
- 11 .. Warning acknowledged (active)
- 13 .. Warning not acknowledged (inactive)
- 15 .. Warning not acknowledged (active)
  
- 17 .. Alarm acknowledged (inactive)
- 19 .. Alarm acknowledged (active)
- 21 .. Alarm not acknowledged (inactive)
- 23 .. Alarm not acknowledged (active)
  
- 25 .. Alarm and warning acknowledged (inactive)
- 27 .. Alarm and warning acknowledged (active)
- 29 .. Alarm and warning not acknowledged (inactive)
- 31 .. Alarm and warning not acknowledged (active)

The terms 'acknowledged' and 'not acknowledged' define, if the reset-push-button on the Hiromatic has been pressed once in order to silence the buzzer or if the command 'Alarm Acknowledge' has been performed.

The terms 'active' and 'inactive' define, if the alarm, warning or message is still active, which means that after performing a alarm-reset (either by sending the appropriate command via the

Modbus-network or by pressing the reset-push-button on the Hiromatic a second time) the alarm or warning will be reported again.

### System-Status (Input Register #8) and Single Status (Input Registers #9 - #24):

This item holds a value, which represents the current system-state of the whole system and of the single Powerfaces. The values correspond to the following states:

- 0 .. Alarm Off
- 1 .. Manual
- 2 .. Local Off
- 3 .. System Off
- 4 .. Standby Alarm
- 5 .. Standby
- 6 .. Sleep / Off
- 7 .. System On
- 8 .. Warning On
- 9 .. Alarm On
- 10 .. Sleep

### 3.5 Events

#### 3.5.1 Event-Registers

Starting from 'Hirolink for Modbus - V 2.85', there is the possibility to read the current state of a single event through Input-Registers, where each bit of these registers represents the state of one event:

Examples:

Input-Register #5001:

State of Hiromatic-events from ID 0 to 15

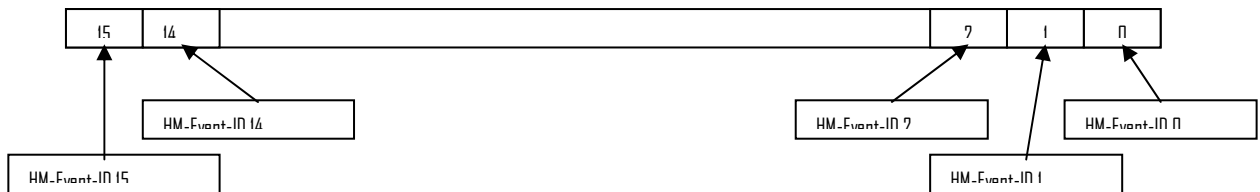

Input-Register #5009:

State of Powerface-events from ID 0 to 15 from Powerface with ID #1

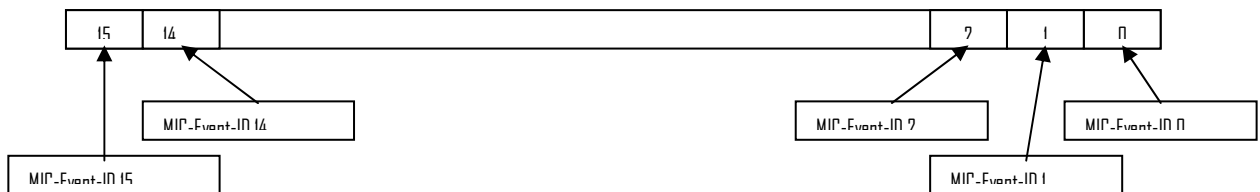

Register #	Usage
5001	Hiromatic-events #0-#15
5002	Hiromatic-events #16-#31
...	...
5008	Hiromatic-events #112-#127
5009	Powerface #1-events #0-#15
5010	Powerface #1-events #16-#31
...	...
5016	Powerface #1-events #112-#127
5017	Powerface #2-events #0-#15
5018	Powerface #2-events #16-#31
...	...
5024	Powerface #2-events #112-#127
...	...
5129	Powerface #16-events #0-#15
5130	Powerface #16-events #16-#31
...	...
5136	Powerface #16-events #112-#127

The following chapter contains a list with all events available for this unit-type. Unused event-IDs will always be set to 0.

**NOTE:**

Events of type 'Message' and 'Reset' (see Event-list in the following chapter), will NOT cause a bit to be set in the Event-registers when they are reported by the Hiromatic. Furthermore, the events 'UNIT CONNECTED' (Event-ID 100) and 'UNIT NOT CONNECTED' (Event-ID 101), which are generated by the Hirolink itself, are also NOT available as single bits within the Event-registers.

These events are only available through the 'Status Report Block' (Input registers #1 - #6) described in chapter 3.4 'Input-Register'.

**For these controls boards and its applications the event registers are upgraded only if the 'Status-Report-Acknowledge' jumper is set; so Hirolink does the upgrades mandatorily** (for more information see Modbus General Documentatio Chapter '5.4 The Status-Report').

### 3.5.2 Event-List

**IMPORTANT:**

If you intend to read the current events through the 'Status Report Block' (Input-Registers #1 - #6), please read the document 'Hirolink for Modbus V X.XX - General Documentation' (X.XX is a placeholder for the current version of the Hirolink) for a detailed description on how to use these data-points.

In the following list you can see all Events and Event-IDs available for ENG-units:

Event-ID	Event-Description	Event-Type	SW-Version
0	GENERAL ALARM	Reset	1.60+
1	COMPRESSOR 1 HIGH PRESSURE	Alarm	1.60+
2	COMPRESSOR 1 LOW PRESSURE	Alarm	1.60+
3	HIGH CHILLED WATER	Warning	1.60+
4	LOW CHILLED WATER FLOW	Warning	1.60+
5	ELECTRICAL HEATERS OVERHEATED	Warning	1.60+
6	FAN FAILURE	Warning	1.60+
7	FAN FAILURE	Alarm	1.60+
8	CLOGGED FILTERS	Warning	1.60+
9	WATER LEAKAGE	Warning	1.60+
10	WATER LEAKAGE	Alarm	1.60+
11	USER INPUT 1 TRIGGERED	Warning	1.60+
12	USER INPUT 1 TRIGGERED	Alarm	1.60+
13	HUMIDIFIER FAILURE	Warning	1.60+
14	HUMIDIFIER HIGH CURRENT	Warning	1.60+
15	HUMIDIFIER FAILURE	Warning	1.60+
16	HUMIDIFIER FAILURE	Warning	1.60+
17	HUMIDIFIER CYLINDER WORN	Warning	1.60+
18	HIGH ROOM TEMPERATURE	Warning	1.60+
19	LOW ROOM TEMPERATURE	Warning	1.60+
20	HIGH ROOM HUMIDITY	Warning	1.60+
21	LOW ROOM HUMIDITY	Warning	1.60+
22	HIGH ROOM TEMPERATURE	Warning	1.60+
23	LOW ROOM TEMPERATURE	Warning	1.60+
24	HIGH ROOM HUMIDITY	Warning	1.60+
25	LOW ROOM HUMIDITY	Warning	1.60+
26	CONDITIONER WORKING HOURS EXCEEDED	Warning	1.60+
27	COMPRESSOR 1 WORKING HOURS EXCEEDED	Warning	1.60+
28	HUMIDIFIER WORKING HOURS EXCEEDED	Warning	1.60+
29	PTC SENSOR FAILURE	Warning	1.60+
30	ROOM SENSOR FAILURE	Warning	1.60+
31	ROOM SENSOR FAILURE	Alarm	1.60+
32	EEAP SENSOR FAILURE	Warning	1.60+
33	WATER PRESENCE SENSOR FAILURE	Warning	1.60+
34	NETWORK FAILURE	Warning	1.60+
35	OUT OF MEMORY	Warning	1.60+
36	UNIT ON	Message	1.60+
37	UNIT OFF	Message	1.60+
38	SLEEP MODE	Message	1.60+
39	STANDBY MODE	Message	1.60+
40	POWER ON	Message	1.60+
41	POWER OFF	Message	1.60+
42	UNIT 1 DISCONNECTED	Warning	1.60+



Hirolink for Modbus V 2.97 - Items for ENG Units V 1.60+

43	UNIT 2 DISCONNECTED	Warning	1.60+
44	UNIT 3 DISCONNECTED	Warning	1.60+
45	UNIT 4 DISCONNECTED	Warning	1.60+
46	UNIT 5 DISCONNECTED	Warning	1.60+
47	UNIT 6 DISCONNECTED	Warning	1.60+
48	UNIT 7 DISCONNECTED	Warning	1.60+
49	UNIT 8 DISCONNECTED	Warning	1.60+
50	UNIT 9 DISCONNECTED	Warning	1.60+
51	UNIT 10 DISCONNECTED	Warning	1.60+
52	UNIT 11 DISCONNECTED	Warning	1.60+
53	UNIT 12 DISCONNECTED	Warning	1.60+
54	UNIT 13 DISCONNECTED	Warning	1.60+
55	UNIT 14 DISCONNECTED	Warning	1.60+
56	UNIT 15 DISCONNECTED	Warning	1.60+
57	UNIT 16 DISCONNECTED	Warning	1.60+
58	COMPRESSOR 2 HIGH PRESSURE	Alarm	1.60+
59	COMPRESSOR 2 LOW PRESSURE	Alarm	1.60+
60	COMPRESSOR 2 WORKING HOURS EXCEEDED	Warning	1.60+
61	OUTDOOR TEMPERATURE SENSOR	Warning	1.60+
62	GLYCOL TEMPERATURE SENSOR	Warning	1.60+
63	FREECOOLING STOPPED FOR 1 HOUR	Message	1.60+
64	ON-OFF BY HIROMATIC NOT ENABLED	Message	1.60+
65	SMOKE ALARM	Alarm	1.60+
66	NO POWER (USER INPUT)	Message	1.60+
67	POWER ON (USER INPUT)	Message	1.60+
68	USER INPUT 2 TRIGGERED	Warning	1.60+
69	USER INPUT 2 TRIGGERED	Alarm	1.60+
70	NO CONNECTION TO UNIT 1	Warning	1.60+
71	COMPRESSOR 1 MOTOR PROTECTION	Alarm	1.60+
72	COMPRESSOR 2 MOTOR PROTECTION	Alarm	1.60+
73	FIRE ALARM	Alarm	1.60+
74	OUT OF MEMORY	Warning	1.60+
75	CONDENSER 1 FAN FAILURE	Warning	1.60+
76	CONDENSER 2 FAN FAILURE	Warning	1.60+
77	HIROBUS ERROR	Warning	1.60+
78	SUBGROUP-ID NOT UNIQUE	Warning	1.60+
79	SUBGROUP-UNIT 1 NOT CONNECTED	Warning	1.60+
80	SUBGROUP-UNIT 2 NOT CONNECTED	Warning	1.60+
81	SHARE ROOM SENSOR FAILURE	Warning	1.60+
82	SHARE ROOM SENSOR FAILURE	Alarm	1.60+
83	SHARE OUTDOOR TEMPERATURE SENSOR	Warning	1.60+
84	SHARE GLYCOL TEMPERATURE SENSOR	Warning	1.60+
85	UNIT SYNCHRONISATION	Message	1.60+
86	HUMIDIFIER HIGH TEMPERATURE	Alarm	1.60+
87	HUMIDIFIER OVERFLOW	Alarm	1.60+
88	HEATER 1/2 WORKING HOURS EXCEEDED	Warning	1.60+
89	FREECOOLING WORKING HOURS EXCEEDED	Warning	1.60+
90	AIRFLOW DEVICE NOT READY, PLEASE CHECK	Warning	1.60+
100	UNIT CONNECTED	Message	1.60+
101	UNIT NOT CONNECTED	Message	1.60+

## ***A.Document-Changes***

This appendix contains all changes that have been applied to this document up to the current version:

This is the first version of this document.

## Connectivity



*The evolution*

# Hirolink for Modbus V 2.99

Items for EV Legacy - 'ICOM board' – Units V 1.60+

Service Manual

English

Code 272401 02/11/06 Release 1.00E

## CONTENTS

<b>1.</b>	<b>INTRODUCTION .....</b>	<b>3</b>
<b>2.</b>	<b>COMPATIBILITY-LIST .....</b>	<b>3</b>
<b>3.</b>	<b>ITEMS FOR ICOM BOARD-TYPE WXM ‘ICOM BOARD’ .....</b>	<b>6</b>
3.1	COILS .....	6
3.2	INPUT-STATUS .....	6
3.3	HOLDING REGISTER .....	7
3.4	INPUT-REGISTER .....	9
3.5	EVENTS .....	11
3.5.1	<i>Event-Registers</i> .....	11
3.5.2	<i>Event-List</i> .....	12
<b>A.</b>	<b>DOCUMENT-CHANGES .....</b>	<b>14</b>

## 1. Introduction

This document contains a description of all data-points that are available via the ‘Hirolink for Modbus’ from this type of air-conditioner.

### **IMPORTANT:**

It is vital to the correct integration of the Hirolink into a Modbus-network, that you have read and understood the topics described in the document ‘Hirolink for Modbus V X.XX - General Documentation’ (X.XX is a placeholder for the current version of the Hirolink). So, if you haven’t read this document until now, read it first.

## 2. Compatibility-List

### ***Preparing the iCOM board***

- Note: there are 2 different types of **iCOM board** available:
  - **Medium board**and
  - **Large board**

The following steps will describe the actions to be done for both types.

To prepare the iCOM board for a connection to the Hirolink, carry out the following actions:

### **Step 1: Check the Hironet-settings (Medium and Large boards)**

In order to verify-modify the Hironet-ID-settings it is necessary to have at least one of these displays:

- 3-Digit display
- Cold Fire Displays
- Hiromatic E

connects to the iCOM board and find the “id” parameter.

These settings define the Identification-number and the baudrate and in some cases also the protocol and the communication-mode. Each of these settings is described in the following:

### ***Identification-number:***

The identification-number set on the iCOM board defines the Modbus-Slave-ID, which has to be used to request data from the iCOM board. As mentioned in the description of the protocol, this Slave-ID must be unique. Therefore it is very important that each iCOM board receives a different identification-number.

After setting the identification-number, note it together with the software-information described in step 1. It is good advise to also note the position of the iCOM board within the building.

### ***Baudrate:***

It is fixed to 19200Bd.

## Step 2: Modbus Network structure (iCOM Medium-Large connections)

### Medium board:

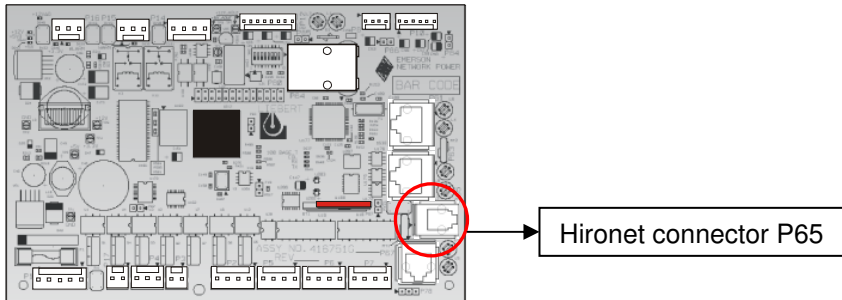

### Large board:

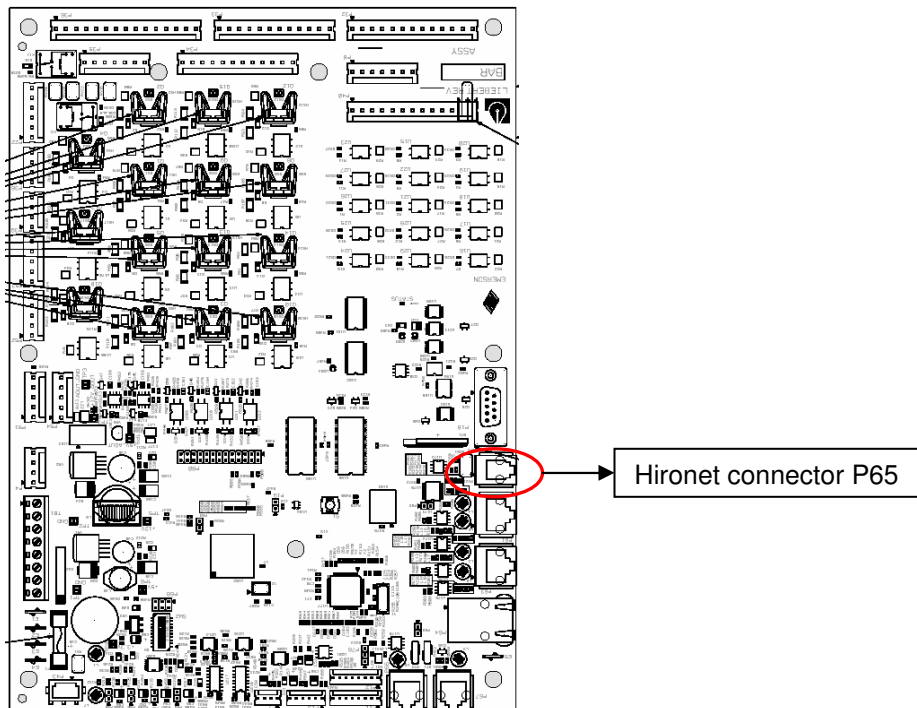

A **T-connector** for RJ9 type can be used when more iCOM board need to be connected together. The T-connector makes the connection task easy (T-connector Code 275655).

This network-type is easy to install and therefore commonly used. You have to use a 4-wire cable, where the connection is done in a 1-to-1 manner. This means that each pin on one interface-card has to be connected to the same pin on the next interface-card.

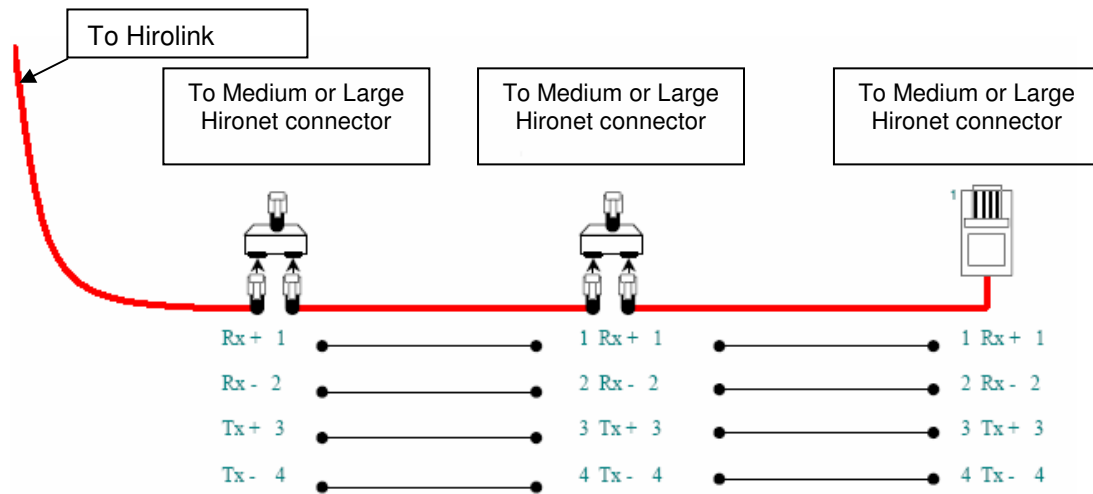

### **3. Items for iCOM board WXM ‘ICOM board’**

According to the Modbus-protocol-specifications the values and parameters provided by the ICOM board are represented in 4 groups:

- Coils: Used for changeable, digital values
- Inputs: Used for not changeable, digital values
- Holding Registers: Used for changeable, analog values
- Input Registers: Used for not changeable, analog values

Therefore the column ‘SW-Version’ contained in the following lists provides information about the availability of each item depending on the iCOM board-software-version. For example an entry like ‘1.60+’ means, that this item is available from ICOM boards with software-version 1.60 and higher.

**IMPORTANT:**

The available data-points shown in the following chapters are numbered starting from 1, according to the Modbus-Protocol-Specification. Still some BMS start numbering the data-points from 0.

So, in case that the BMS you are using starts numbering from 0, you have to decrease the listed numbers by 1.

#### **3.1 Coils**

Not used on this ICOM board-type.

#### **3.2 Input-Status**

Not used on this ICOM board-type.



### 3.3 Holding Register

Register #	Usage	Range; Unit	SW-Version
1	Status-Report-Acknowledge	See explanation below	1.60+
2	Alarm Status	See explanation below	1.60+
3	Unit System On/Off	0 -> Unit System Off; 1 -> Unit System On	1.60+
4	Heater Working Hours	0 - 32000; [h]	1.60+
5	Humidifier Working Hours	0 - 32000; [h]	1.60+
6	Compressor 1 Working Hours	0 - 32000; [h]	1.60+
7	Conditioner Working Hours	0 - 32000; [h]	1.60+
8	Sleep Mode Reset	0 -> No, 1 -> Yes, 2 -> Auto	1.60+
9	Sleep Mode Second Interval TO Minutes	0 - 59; [min]	1.60+
10	Sleep Mode Second Interval TO Hours	0 - 23; [h]	1.60+
11	Sleep Mode Second Interval FROM Minutes	0 - 59; [min]	1.60+
12	Sleep Mode Second Interval FROM Hours	0 - 23; [h]	1.60+
13	Sleep Mode First Interval TO Minutes	0 - 59; [min]	1.60+
14	Sleep Mode First Interval TO Hours	0 - 23; [h]	1.60+
15	Sleep Mode First Interval FROM Minutes	0 - 59; [min]	1.60+
16	Sleep Mode First Interval FROM Hours	0 - 23; [h]	1.60+
17	Low Pressure Delay Time	0 - 5; [min]	1.60+
18	Low Humidity Warning	0 -> No, 1 - 99; [%RH]	1.60+
19	High Humidity Warning	0 -> No, 1 - 99; [%RH]	1.60+
20	Low Temperature Warning	0 -> No, 1 - 99; [°C]	1.60+
21	High Temperature Warning	0 -> No, 1 - 99; [°C]	1.60+
22	Number of Standby Units	0 - 16	1.60+
23	Humidity Integral Factor	4 -> No, 5 - 15; [min]	1.60+
24	Temperature Integral Factor	4 -> No, 5 - 15; [min]	1.60+
25	Humidity Proportional Band	5 - 20; [%RH]	1.60+
26	Temperature Proportional Band	10 - 100; [1/10 K]	1.60+
27	Shared Parameters	0 -> No, 1 -> Yes	1.60+
28	Fanspeed	29 -> No, 30 - 100; [%]	1.60+
29	Supply Air Setpoint	5 - 25; [°C]	1.60+
30	Room Humidity Setpoint	19 -> No; 20 - 80; [%RH]	1.60+
31	Room Temperature Setpoint 1	50 - 400; [1/10 °C]	1.60+
32	Room Temperature Setpoint 2	4 -> No, 5 - 40; [1/10 °C]	1.60+
33	Compressor 2 Working Hours	0 - 32000; [h]	1.60+
34	Freecooling Working Hours	0 - 32000; [h]	1.60+
35	Stop Freecooling at	0 -> No, 1 - 25; [K]	1.60+
36	Freecooling Difference between room and glycol temperature	0 -> No, 1 - 25; [K]	1.60+
37	Freecooling Difference between room and ambient temperature	0 -> No, 1 -> EFC, 1 - 25; [K]	1.60+

## Status-Report-Acknowledge (Holding Register #1):

Read the document ‘Hiolink for Modbus V X.XX - General Documentation’ (X.XX is a placeholder for the current version of the Hiolink) for a description on how to use this data-point.

## Alarm-Status (Holding Registers #2):

This item holds a value which represents the current alarm-state of single ICOM board.

It can be written to in order to perform either a ‘Alarm Acknowledge’- or a ‘Alarm Reset’-command on a single ICOM board:

### 2 .. Alarm Reset:

This command will reset all alarms, warnings and messages currently present on a ICOM board. As a consequence alarms, warnings and messages that are inactive will disappear, will active alarms, warnings and messages will be reported again.

### 4 .. Alarm Acknowledge:

This command will acknowledge all alarms, warnings and messages present on a ICOM board. As a consequence alarms, warnings and messages that were in an unacknowledged state will be acknowledged after the command.

When read, the value corresponds to the following states:

- 0 .. No alarm present
- 1 .. Message acknowledged (inactive)
- 3 .. Message acknowledged (active)
- 5 .. Message not acknowledged (inactive)
- 7 .. Message not acknowledged (active)
- 9 .. Warning acknowledged (inactive)
- 11.. Warning acknowledged (active)
- 13.. Warning not acknowledged (inactive)
- 15.. Warning not acknowledged (active)
- 17.. Alarm acknowledged (inactive)
- 19.. Alarm acknowledged (active)
- 21...Alarm not acknowledged (inactive)
- 23.. Alarm not acknowledged (active)
- 25.. Alarm and warning acknowledged (inactive)
- 27.. Alarm and warning acknowledged (active)
- 29.. Alarm and warning not acknowledged (inactive)
- 31.. Alarm and warning not acknowledged (active)

The terms ‘acknowledged’ and ‘not acknowledged’ define, if the reset-push-button on the **iCOM Cold fire display** has been pressed once or if the ‘Alarm Acknowledge’ command has been performed by BMS in order to silence the buzzer.

The terms ‘active’ and ‘inactive’ define, if the alarm, warning or message is still active, which means that after performing an alarm-reset (either by sending the appropriate command via the Modbus-network or by pressing the reset-push-button on the **iCOM Cold fire display** a second time) the alarm or warning will be reported again in case the alarm situation is still present.

**NOTE:**

Although you can read the alarm-state of the whole system (see 3.4 ‘Input-Register’), it is not possible to issue an ‘Alarm Acknowledge’- or ‘Alarm Reset’-command for the whole system. Instead you have to issue these commands for each ICOM board separately.

**3.4 Input-Register**

Register #	Usage	Range; Unit	SW-Version
1	Event-ID	ID identifying the event	1.60+
2	Controller-ID	Controller-ID, where the event occurred	1.60+
3	Minute	Minute, when event occurred	1.60+
4	Hour	Hour, when event occurred	1.60+
5	Date	Date, when event occurred	1.60+
6	Event-Type	0 -> message, 1 -> warning 2 -> alarm, 3 and 4 -> reset	1.60+
7	Alarm Status	See explanation below	1.60+
8	Unit Status	See explanation below	1.60+
9	Cooling Ramp	0 - 100; [%]	1.60+
10	Status Dehumidification	0 -> Off, 1 -> On	1.60+
11	Status Electrical Heater 2	0 -> Off, 1 -> On	1.60+
12	Status Electrical Heater 1	0 -> Off, 1 -> On	1.60+
13	Status Compressor 1	0 -> Off, 1 -> On	1.60+
14	Status Fan	0 -> Off, 1 -> On	1.60+
15	Room Humidity	0-1000; [1/10 %RH]; see explanation below	1.60+
16	Room Temperature	-300 - 1000; [1/10 °C]; see explanation below	1.60+
17	Supply Air Temperature	-300 - 1000; [1/10 °C]; see explanation below	1.60+
18	Humidifier Current	0 - 4000; [1/100 A]	1.60+
19	Hirotemp 1 Value 2	-300 - 1000; [1/10 °C]	1.60+
20	Hirotemp 1 Value 1	-300 - 1000; [1/10 °C]	1.60+
21	Actual Temperature Setpoint	50 - 400; [1/10 °C]	1.60+
22	Status Compressor 2	0 -> Off; 1 -> On	1.60+
23	Glycol Temperature	-300 - 1000; [1/10 °C]	1.60+
24	Outdoor Temperature	-300 - 1000; [1/10 °C]	1.60+
25	Freecooling Status	0 -> FC Off; 1 -> FC Start; 2 -> FC On; 3 -> No FC Mode	1.60+
26	Radcooler Ramp	0 - 100; [%]	1.60+

### Status-Report-Block (Input Register #1 - #6):

Read the document ‘Hirolink for Modbus V X.XX - General Documentation’ (X.XX is a placeholder for the current version of the Hirolink) for a description on how to use these data-points.

### Alarm Status (Input Register #7):

This item holds a value, which represents the current alarm-state of the whole system. This alarm-state is calculated from the single alarm-states of each ICOM board and holds the highest of those alarm-states. The single alarm-states can be read using the appropriate Holding Registers (see 3.3 ‘Holding Register’).

The values correspond to the following states:

- 0 .. No alarm present
- 1 .. Message acknowledged (inactive)
- 3 .. Message acknowledged (active)
- 5 .. Message not acknowledged (inactive)
- 7 .. Message not acknowledged (active)
  
- 9 .. Warning acknowledged (inactive)
- 11 .. Warning acknowledged (active)
- 13 .. Warning not acknowledged (inactive)
- 15 .. Warning not acknowledged (active)
  
- 17 .. Alarm acknowledged (inactive)
- 19 .. Alarm acknowledged (active)
- 21 .. Alarm not acknowledged (inactive)
- 23 .. Alarm not acknowledged (active)
  
- 25 .. Alarm and warning acknowledged (inactive)
- 27 .. Alarm and warning acknowledged (active)
- 29 .. Alarm and warning not acknowledged (inactive)
- 31 .. Alarm and warning not acknowledged (active)

The terms ‘acknowledged’ and ‘not acknowledged’ define, if the reset-push-button on the iCOM Cold fire display or Hiromatic E has been pressed once in order to silence the buzzer or if the ‘Alarm Acknowledge’ command has been performed by BMS in order to silence the buzzer.

The terms ‘active’ and ‘inactive’ define, if the alarm, warning or message is still active, which means that after performing an alarm-reset (either by sending the appropriate command via the Modbus-network or by pressing the reset-push-button on the iCOM Cold fire display or Hiromatic E a second time) the alarm or warning will be reported again.

### Unit Status (Input Register #8):

This item holds a value, which represents the current system-state of the whole system and of the single ICOM boards. The values correspond to the following states:

- 0 .. Alarm Off
- 1 .. Manual
- 2 .. Local Off
- 3 .. System Off
- 4 .. Standby Alarm
- 5 .. Standby
- 6 .. Sleep / Off
- 7 .. System On
- 8 .. Warning On
- 9 .. Alarm On
- 10 .. Sleep

### Room Humidity (Input Registers #15), Room Temperature (Input Registers #16) and Supply Air Temperature (Input Register #17):

In case of NO Humitemp-sensor being used to measure the current room temperature and humidity, the ‘Supply Air Temperature’-input-registers will hold the current room temperature and the ‘Room Temperature’- and ‘Room Humidity’-input-registers will be invalid.

## 3.5 Events

### 3.5.1 Event-Registers

Starting from ‘Hirolink for Modbus - V 2.85’, there is the possibility to read the current state of a single event through Input-Registers, where each bit of these registers represents the state of one event:

Examples:

Input-Register #5001:  
State of ICOM board-events from ID 0 to 15

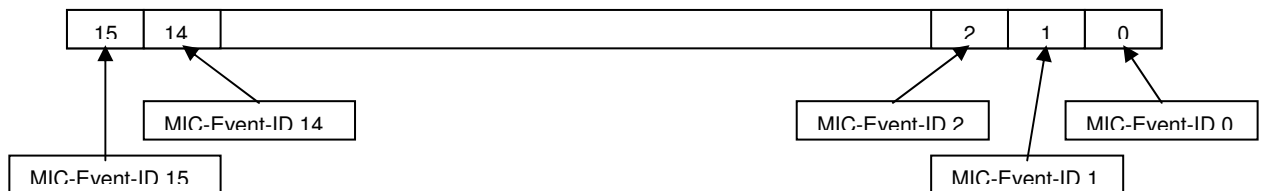

Register #	Usage
5001	ICOM board events #0-#15
5002	ICOM board events #16-#31
...	...
5008	ICOM board events #112-#127

The following chapter contains a list with all events available for this unit-type. Unused event-IDs will always be set to 0.

#### NOTE:

It events of type ‘Message’ and ‘Reset’ (see Event-list in the following chapter), will NOT cause a bit to be set in the Event-registers.  
Furthermore, the events ‘UNIT CONNECTED’ (Event-ID 100) and ‘UNIT NOT CONNECTED’ (Event-ID 101), which are generated by the Hirolink itself, are also NOT available as single bits within the Event-registers.

These events are only available through the ‘Status Report Block’ (Input registers #1 - #6) described in chapter 3.4 ‘Input-Register’.

**For these controls boards and its applications the event registers are upgraded only if the ‘Status-Report-Acknowledge’ jumper is set; so Hirolink does the upgrades mandatorily** (for more information see Modbus General Documentatio Chapter ‘5.4 The Status-Report’).

### 3.5.2 Event-List

**IMPORTANT:**

If you intend to read the current events through the ‘Status Report Block’ (Input-Registers #1 - #6), please read the document ‘Hirolink for Modbus V X.XX - General Documentation’ (X.XX is a placeholder for the current version of the Hirolink) for a detailed description on how to use these data-points.

In the following list you can see all Events and Event-IDs available for WXG-units:

Event-ID	Event-Description	Event-Type	SW-Version
0	GENERAL ALARM	Reset	1.60+
1	COMPRESSOR 1 HIGH PRESSURE	Alarm	1.60+
2	COMPRESSOR 1 LOW PRESSURE	Alarm	1.60+
3	HIGH CHILLED WATER TEMPERATURE	Warning	1.60+
4	LOW CHILLED WATER FLOW	Warning	1.60+
5	ELECTRICAL HEATERS OVERHEATED	Warning	1.60+
6	FAN FAILURE	Warning	1.60+
7	FAN FAILURE	Alarm	1.60+
8	CLOGGED FILTERS	Warning	1.60+
9	WATER LEAKAGE DETECTED	Warning	1.60+
10	WATER LEAKAGE DETECTED	Alarm	1.60+
11	USER INPUT TRIGGERED	Warning	1.60+
12	USER INPUT TRIGGERED	Alarm	1.60+
13	EXTERNAL HUMIDIFIER FAILURE	Warning	1.60+
14	HUMIDIFIER HIGH CURRENT	Warning	1.60+
15	HUMIDIFIER FAILURE	Warning	1.60+
16	HUMIDIFIER FAILURE	Warning	1.60+
17	HUMIDIFIER CYLINDER WARNING	Warning	1.60+
18	HIGH ROOM TEMPERATURE	Warning	1.60+
19	LOW ROOM TEMPERATURE	Warning	1.60+
20	HIGH ROOM HUMIDITY	Warning	1.60+
21	LOW ROOM HUMIDITY	Warning	1.60+
22	HIGH ROOM TEMPERATURE (EEAP)	Warning	1.60+
23	LOW ROOM TEMPERATURE (EEAP)	Warning	1.60+
24	HIGH ROOM HUMIDITY (EEAP)	Warning	1.60+
25	LOW ROOM HUMIDITY (EEAP)	Warning	1.60+
26	CONDITIONER WORKING HOURS EXCEEDED	Warning	1.60+
27	COMPRESSOR 1 WORKING HOURS EXCEEDED	Warning	1.60+
28	HUMIDIFIER WORKING HOURS EXCEEDED	Warning	1.60+
29	PTC SENSOR FAILURE	Warning	1.60+
30	ROOM SENSOR FAILURE	Warning	1.60+
31	ROOM SENSOR FAILURE	Alarm	1.60+
32	EEAP SENSOR FAILURE	Warning	1.60+
33	WATER PRESENCE SENSOR FAILURE	Warning	1.60+
34	NETWORK FAILURE	Warning	1.60+
35	OUT OF MEMORY	Warning	1.60+
36	UNIT ON	Message	1.60+
37	UNIT OFF	Message	1.60+
38	SLEEP MODE	Message	1.60+
39	STANDBY MODE	Message	1.60+
40	POWER ON	Message	1.60+
41	POWER OFF	Message	1.60+
42	UNIT 1 DISCONNECTED	Alarm	1.60+

43	UNIT 2 DISCONNECTED	Alarm	1.60+
44	UNIT 3 DISCONNECTED	Alarm	1.60+
45	UNIT 4 DISCONNECTED	Alarm	1.60+
46	UNIT 5 DISCONNECTED	Alarm	1.60+
47	UNIT 6 DISCONNECTED	Alarm	1.60+
48	UNIT 7 DISCONNECTED	Alarm	1.60+
49	UNIT 8 DISCONNECTED	Alarm	1.60+
50	UNIT 9 DISCONNECTED	Alarm	1.60+
51	UNIT 10 DISCONNECTED	Alarm	1.60+
52	UNIT 11 DISCONNECTED	Alarm	1.60+
53	UNIT 12 DISCONNECTED	Alarm	1.60+
54	UNIT 13 DISCONNECTED	Alarm	1.60+
55	UNIT 14 DISCONNECTED	Alarm	1.60+
56	UNIT 15 DISCONNECTED	Alarm	1.60+
57	UNIT 16 DISCONNECTED	Alarm	1.60+
58	COMPRESSOR 2 HIGH PRESSURE	Alarm	1.60+
59	COMPRESSOR 2 LOW PRESSURE	Alarm	1.60+
60	COMPRESSOR 2 WORKING HOURS EXCEEDED	Warning	1.60+
61	OUTDOOR TEMPERATURE SENSOR FAILURE	Warning	1.60+
62	GLYCOL TEMPERATURE SENSOR FAILURE	Warning	1.60+
63	FREECOOLING STOPPED FOR 1 HOUR	Message	1.60+
64	ON-OFF BY HIROMATIC NOT ENABLED	Warning	1.60+
65	SMOKE ALARM	Warning	1.60+
66	NO POWER (USER INPUT)	Message	1.60+
67	POWER ON (USER INPUT)	Message	1.60+
68	USER INPUT 2 TRIGGERED	Warning	1.60+
69	USER INPUT 2 TRIGGERED	Alarm	1.60+
70	NO CONNECTION TO UNIT 1	Warning	1.60+
71	COMPRESSOR 1 MOTOR PROTECTION	Alarm	1.60+
72	COMPRESSOR 2 MOTOR PROTECTION	Alarm	1.60+
73	FIRE ALARM	Alarm	1.60+
74	OUT OF MEMORY	Warning	1.60+
75	CONDENSER 1 FAN FAILURE	Warning	1.60+
76	CONDENSER 2 FAN FAILURE	Warning	1.60+
77	HIROBUS ERROR	Warning	1.60+
78	SUBGROUP-ID NOT UNIQUE	Warning	1.60+
79	SUBGROUP-UNIT 1 NOT CONNECTED	Warning	1.60+
80	SUBGROUP-UNIT 2 NOT CONNECTED	Warning	1.60+
81	SHARE ROOM SENSOR FAILURE	Warning	1.60+
82	SHARE ROOM SENSOR FAILURE	Alarm	1.60+
83	SHARE OUTDOOR TEMP. SENSOR	Warning	1.60+
84	SHARE GLYCOL TEMP. SENSOR	Warning	1.60+
85	UNIT SYNCHRONISATION (=Short Reset)	Message	1.60+
86	HUMIDIFIER HIGH TEMPERATURE	Alarm	1.60+
87	HUMIDIFIER OVERFLOW	Alarm	1.60+
88	HEATER 1/2 WORKING HOURS EXCEEDED	Alarm	1.60+
89	FREECOOLING WORKING HOURS EXCEEDED	Alarm	1.60+
90	AIRFLOW DEVICE NOT READY, PLEASE CHECK	Alarm	1.60+
100	UNIT CONNECTED	Message	1.60+
101	UNIT NOT CONNECTED	Message	1.60+

## ***A.Document-Changes***

This appendix contains all changes that have been applied to this document up to the current version:

This is the first version of this document.



## Connectivity

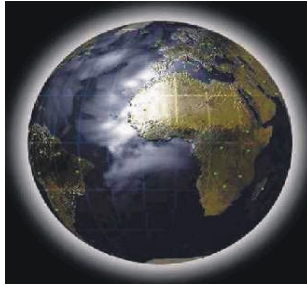

*The evolution*

# Hirolink for Modbus V 3.00

(17) Items for Data Gathering Panel - DGP (DIM) (Microface)

Service Manual

English

Code 272401 06/04/07 Release 1.00E

## CONTENTS

<b>1.</b>	<b>INTRODUCTION .....</b>	<b>3</b>
<b>2.</b>	<b>COMPATIBILITY-LIST .....</b>	<b>3</b>
<b>3.</b>	<b>ITEMS FOR DATA GATHERING PANEL - DGP (DIM) .....</b>	<b>4</b>
3.1	COILS .....	4
3.2	INPUT-STATUS .....	4
3.3	HOLDING REGISTER.....	5
3.4	INPUT-REGISTER.....	7
3.5	EVENTS.....	9
3.5.1	<i>Event-Registers</i> .....	9
3.5.2	<i>Event-List</i> .....	10
<b>A.</b>	<b>DOCUMENT-CHANGES .....</b>	<b>17</b>

## 1. Introduction

This document contains a description of all data-points that are available via the 'Hirolink for Modbus' from this type of air-conditioner.

### **IMPORTANT 1:**

Units of the above mentioned type do not use Hiromatic to connect to the Hirolink Modbus, but data are transmitted directly from the Microface RS485 port (multiple units need to be interconnected with Hirobus as well with Hironet cable (Hironet uses T-connectors, as there is only 1 RS485 connector on the Microface). Cabling / pinning exactly like Hiromatic E, see Hironet Connection Guide cod.272179).

### **IMPORTANT 2:**

It is vital to the correct integration of the Hirolink into a Modbus-network, that you have read and understood the topics described in the document 'Hirolink for Modbus V X.XX - General Documentation' (X.XX is a placeholder for the current version of the Hirolink). So, if you haven't read this document until now, read it first.

## 2. Compatibility-List

Before connecting a Microface to the Modbus-Hirolink you must check, if the Microface-software-version is compatible with this version of the Hirolink.

You can do this by checking the labels on the Eproms, which are inserted into the Microface. The Eprom inserted in the Microface must be called DIM + Version-Number (e.g. **DIM 1.04.000**).

### 3. Items for Data Gathering Panel - DGP (DIM)

According to the Modbus-protocol-specifications the values and parameters provided by the Microface are represented in 4 groups:

- Coils: Used for changeable, digital values
- Inputs: Used for not changeable, digital values
- Holding Registers: Used for changeable, analog values
- Input Registers: Used for not changeable, analog values

This Hirolink can be compatible with more than one version of this Microface-type and it is possible that there have been extensions in the number of available items from one version to the next.

Therefore the column 'SW-Version' contained in the following lists provides information about the availability of each item depending on the Hiromatic-software-version. For example a entry like '1.00+' means, that this item is available from Hiromatics with software-version 1.00 and higher.

**IMPORTANT:**

The available data-points shown in the following chapters are numbered starting from 1, according to the Modbus-Protocol-Specification. Still some BMS start numbering the data-points from 0.

So, in case that the BMS you are using starts numbering from 0, you have to decrease the listed numbers by 1.

#### **3.1 Coils**

Not used on this application.

#### **3.2 Input-Status**

Not used on this application.

### 3.3 Holding Register

Register #	Hironet-Variable	Usage	Range; Unit	SW-Version
1	-	Status-Report-Acknowledge	See explanation below	1.04.000+
2	-	Unit Alarm Status	See explanation below	1.04.000+
3	Rtc_Min	Actual minute	0 - 59	1.04.000+
4	Rtc_Hou	Actual hour	0 - 23	1.04.000+
5	Rtc_Day	Actual day	1 - 31	1.04.000+
6	Rtc_Mon	Actual month	1 - 12	1.04.000+
7	Rtc_Yea4	Actual year, 4 digits	1970 - 2069	1.04.000+
8	Main_Displ	Main Display ( 1 = On , 2 = Off).	1 - 2	1.04.000+
9	Ptc1HiTeAt	PTC 1 High Temperature warning at	1 - 99	1.04.000+
10	Ptc1LoTeAt	PTC 1 Low Temperature warning at	1 - 99	1.04.000+
11	Ht11HiTeAt	Hirosensor High Temperature warning at	1 - 99	1.04.000+
12	Ht11LoTeAt	Hirosensor Low Temperature warning at	1 - 99	1.04.000+
13	Ptc2LoTeAt	PTC 2 Low Temperature warning at	1 - 99	1.04.000+
14	Ptc2HiTeAt	PTC 2 High Temperature warning at	1 - 99	1.04.000+
15	Ht12LoTeAt	Hirosensor Low Temperature / Humidity warning at	1 - 99	1.04.000+
16	Ht12HiTeAt	Hirosensor High Temperature / Humiditywarning at	1 - 99	1.04.000+
17	Ptc3HiTeAt	PTC 3 High Temperature warning at	1 - 99	1.04.000+
18	Ptc4HiTeAt	PTC 4 High Temperature warning at	1 - 99	1.04.000+
19	Ptc5HiTeAt	PTC 5 High Temperature warning at	1 - 99	1.04.000+
20	Ptc6HiTeAt	PTC 6 High Temperature warning at	1 - 99	1.04.000+
21	Ptc7HiTeAt	PTC 7 High Temperature warning at	1 - 99	1.04.000+
22	Ptc8HiTeAt	PTC 8 High Temperature warning at	1 - 99	1.04.000+
23	Ptc3LoTeAt	PTC 3 Low Temperature warning at	1 - 99	1.04.000+
24	Ptc4LoTeAt	PTC 4 Low Temperature warning at	1 - 99	1.04.000+
25	Ptc5LoTeAt	PTC 5 Low Temperature warning at	1 - 99	1.04.000+
26	Ptc6LoTeAt	PTC 6 Low Temperature warning at	1 - 99	1.04.000+
27	Ptc7LoTeAt	PTC 7 Low Temperature warning at	1 - 99	1.04.000+
28	Ptc8LoTeAt	PTC 8 Low Temperature warning at	1 - 99	1.04.000+
29	Ptc1_Conn	PTC In usage: 0= digital, 1 = Sensor	0 - 1	1.04.000+
30	Ptc2_Conn	PTC In usage: 0= digital, 1 = Sensor	0 - 1	1.04.000+
31	Ptc3_Conn	PTC In usage: 0= digital, 1 = Sensor	0 - 1	1.04.000+
32	Ptc4_Conn	PTC In usage: 0= digital, 1 = Sensor	0 - 1	1.04.000+
33	Ptc5_Conn	PTC In usage: 0= digital, 1 = Sensor	0 - 1	1.04.000+
34	Ptc6_Conn	PTC In usage: 0= digital, 1 = Sensor	0 - 1	1.04.000+
35	Ptc7_Conn	PTC In usage: 0= digital, 1 = Sensor	0 - 1	1.04.000+
36	Ptc8_Conn	PTC In usage: 0= digital, 1 = Sensor	0 - 1	1.04.000+
37	DelDIP0_1	Digital Input 1 (PTC0) Delay in minutes	-99 - 99	1.04.000+
38	DelDIP0_2	Digital Input 2 (PTC0) Delay in minutes	-99 - 99	1.04.000+
39	DelDIP0_3	Digital Input 3 (PTC0) Delay in minutes	-99 - 99	1.04.000+
40	DelDIP1_4	Digital Input 4 (PTC1) Delay in minutes	-99 - 99	1.04.000+
41	DelDIP1_5	Digital Input 5 (PTC1) Delay in minutes	-99 - 99	1.04.000+
42	DelDIP2_6	Digital Input 6 (PTC2) Delay in minutes	-99 - 99	1.04.000+
43	DelDIP2_7	Digital Input 7 (PTC2) Delay in minutes	-99 - 99	1.04.000+
44	DelDIP3_8	Digital Input 8 (PTC3) Delay in minutes	-99 - 99	1.04.000+
45	DelDIP3_9	Digital Input 9 (PTC3) Delay in minutes	-99 - 99	1.04.000+
46	DelDIP3_10	Digital Input 10 (PTC3) Delay in minutes	-99 - 99	1.04.000+
47	DelDIP4_11	Digital Input 11 (PTC4) Delay in minutes	0 - 99	1.04.000+
48	DelDIP4_12	Digital Input 12 (PTC4) Delay in minutes	0 - 99	1.04.000+
49	DelDIP4_13	Digital Input 13 (PTC4) Delay in minutes	0 - 99	1.04.000+
50	DelDIP5_14	Digital Input 14 (PTC5) Delay in minutes	0 - 99	1.04.000+
51	DelDIP5_15	Digital Input 15 (PTC5) Delay in minutes	0 - 99	1.04.000+
52	DelDIP6_16	Digital Input 16 (PTC6) Delay in minutes	0 - 99	1.04.000+
53	DelDIP6_17	Digital Input 17 (PTC6) Delay in minutes	0 - 99	1.04.000+
54	DelDIP7_18	Digital Input 18 (PTC7) Delay in minutes	0 - 99	1.04.000+
55	DelDIP7_19	Digital Input 19 (PTC7) Delay in minutes	0 - 99	1.04.000+
56	DelDIP7_20	Digital Input 20 (PTC7) Delay in minutes	0 - 99	1.04.000+
57	DigOut0_HL	Digital output setable by Hirolink	0 - 99	1.04.000+
58	DigOut1_HL	Digital output setable by Hirolink	0 - 99	1.04.000+

Items for Data Gathering Panel - DGP (DIM) (Microface)

59	DigOut2_HL	Digital output setable by Hirolink	0 - 99	1.04.000+
60	DigOut3_HL	Digital output setable by Hirolink	0 - 99	1.04.000+
61	DigOut4_HL	Digital output setable by Hirolink	0 - 99	1.04.000+
62	DigOut5_HL	Digital output setable by Hirolink	0 - 99	1.04.000+
63	DigOut6_HL	Digital output setable by Hirolink	0 - 99	1.04.000+
64	HL_DO_Mode	Enables the digital output control over Hirolink	0 - 99	1.04.000+
65	DigOut0Del	Digital Output pulse-time in seconds ( 0 = no pulsing )	0 - 99	1.04.000+
66	DigOut1Del	Digital Output pulse-time in seconds ( 0 = no pulsing )	0 - 99	1.04.000+
67	DigOut2Del	Digital Output pulse-time in seconds ( 0 = no pulsing )	0 - 99	1.04.000+
68	DigOut3Del	Digital Output pulse-time in seconds ( 0 = no pulsing )	0 - 99	1.04.000+
69	DigOut4Del	Digital Output pulse-time in seconds ( 0 = no pulsing )	0 - 99	1.04.000+
70	DigOut5Del	Digital Output pulse-time in seconds ( 0 = no pulsing )	0 - 99	1.04.000+
71	DigOut6Del	Digital Output pulse-time in seconds ( 0 = no pulsing )	0 - 99	1.04.000+

**Status-Report-Acknowledge (Holding Register #1):**

Read the document 'Hirolink for Modbus V X.XX - General Documentation' (X.XX is a placeholder for the current version of the Hirolink) for a description on how to use this data-point.

**Alarm-Status (Holding Registers #2):**

This item holds a value which represents the current alarm-state of single MICROFACE board.

It can be written to in order to perform either a 'Alarm Acknowledge'- or a 'Alarm Reset'- command on a single MICROFACE board:

2 .. Alarm Reset:

This command will reset all alarms, warnings and messages currently present on a MICROFACE board. As a consequence alarms, warnings and messages that are inactive will disappear, will active alarms, warnings and messages will be reported again.

4 .. Alarm Acknowledge:

This command will acknowledge all alarms, warnings and messages present on a MICROFACE board. As a consequence alarms, warnings and messages that were in an unacknowledged state will be acknowledged after the command.

When read, the value corresponds to the following states:

0 .. No alarm present

- 1 .. Message acknowledged (inactive)
- 3 .. Message acknowledged (active)
- 5 .. Message not acknowledged (inactive)
- 7 .. Message not acknowledged (active)

- 9 .. Warning acknowledged (inactive)
- 11.. Warning acknowledged (active)
- 13.. Warning not acknowledged (inactive)
- 15.. Warning not acknowledged (active)

- 17.. Alarm acknowledged (inactive)
- 19.. Alarm acknowledged (active)
- 21...Alarm not acknowledged (inactive)

## Items for Data Gathering Panel - DGP (DIM) (Microface)

- 23.. Alarm not acknowledged (active)
- 25.. Alarm and warning acknowledged (inactive)
- 27.. Alarm and warning acknowledged (active)
- 29.. Alarm and warning not acknowledged (inactive)
- 31.. Alarm and warning not acknowledged (active)

The terms 'acknowledged' and 'not acknowledged' define, if the reset-push-button on the Hiromatic E has been pressed once or if the 'Alarm Acknowledge' command has been performed by BMS in order to silence the buzzer.

The terms 'active' and 'inactive' define, if the alarm, warning or message is still active, which means that after performing an alarm-reset (either by sending the appropriate command via the Modbus-network or by pressing the reset-push-button on the Hiromatic E a second time) the alarm or warning will be reported again in case the alarm situation is still present.

**NOTE:**

Although you can read the alarm-state of the whole system (see 3.4 'Input-Register'), it is not possible to issue an 'Alarm Acknowledge'- or 'Alarm Reset'-command for the whole system. Instead you have to issue these commands for each MICROFACE board separately.

### 3.4 Input-Register

Register #	Hironet-Variable	Usage	Range; Unit	SW-Version
1	-	Event-ID	ID identifying the event	1.04.000+
2	-	Controller-ID	Controller-ID, where the event occurred	1.04.000+
3	-	Minute	Minute, when event occurred	1.04.000+
4	-	Hour	Hour, when event occurred	1.04.000+
5	-	Date	Date, when event occurred	1.04.000+
6	-	Event-Type	0 -> message, 1 -> warning 2 -> alarm, 3 and 4 -> reset	1.04.000+
7	-	Alarm Status	See explanation below	1.04.000+
8	Ht11_Temp	Humitemp Temperature	-300 - 1000	1.04.000+
9	Ht12_Temp	Humitemp Humidity	0 - 1000	1.04.000+
10	Ptc1_Temp	Ptc1 Temperature	-300 - 1000	1.04.000+
11	Ptc2_Temp	Ptc2 Temperature	-300 - 1000	1.04.000+
12	Ptc3_Temp	Ptc3 Temperature	-300 - 1000	1.04.000+
13	Ptc4_Temp	Ptc4 Temperature	-300 - 1000	1.04.000+
14	Ptc5_Temp	Ptc5 Temperature	-300 - 1000	1.04.000+
15	Ptc6_Temp	Ptc6 Temperature	-300 - 1000	1.04.000+
16	Ptc7_Temp	Ptc7 Temperature	-300 - 1000	1.04.000+
17	Ptc8_Temp	Ptc8 Temperature	-300 - 1000	1.04.000+
18	DigInP0_1	Digital Input 1	0 - 1	1.04.000+
19	DigInP0_2	Digital Input 2	0 - 1	1.04.000+
20	DigInP0_3	Digital Input 3	0 - 1	1.04.000+
21	DigInP1_4	Digital Input 4	0 - 1	1.04.000+
22	DigInP1_5	Digital Input 5	0 - 1	1.04.000+
23	DigInP2_6	Digital Input 6	0 - 1	1.04.000+
24	DigInP2_7	Digital Input 7	0 - 1	1.04.000+
25	DigInP3_8	Digital Input 8	0 - 1	1.04.000+
26	DigInP3_9	Digital Input 9	0 - 1	1.04.000+
27	DigInP3_10	Digital Input 10	0 - 1	1.04.000+
28	DigInP4_11	Digital Input 11	0 - 1	1.04.000+
29	DigInP4_12	Digital Input 12	0 - 1	1.04.000+
30	DigInP4_13	Digital Input 13	0 - 1	1.04.000+
31	DigInP5_14	Digital Input 14	0 - 1	1.04.000+
32	DigInP5_15	Digital Input 15	0 - 1	1.04.000+
33	DigInP6_16	Digital Input 16	0 - 1	1.04.000+
34	DigInP6_17	Digital Input 17	0 - 1	1.04.000+
35	DigInP7_18	Digital Input 18	0 - 1	1.04.000+
36	DigInP7_19	Digital Input 19	0 - 1	1.04.000+
37	DigInP7_20	Digital Input 20	0 - 1	1.04.000+

### Status-Report-Block (Input Register #1 - #6):

Read the document 'Hirolink for Modbus V X.XX - General Documentation' (X.XX is a placeholder for the current version of the Hirolink) for a description on how to use these data-points.

### Alarm Status (Input Register #7):

This item holds a value, which represents the current alarm-state of the whole system. This alarm-state is calculated from the single alarm-states of each MICROFACE board and holds the highest of those alarm-states. The single alarm-states can be read using the appropriate Holding Registers (see 3.3 'Holding Register').

The values correspond to the following states:

- 0 .. No alarm present
- 1 .. Message acknowledged (inactive)
- 3 .. Message acknowledged (active)
- 5 .. Message not acknowledged (inactive)
- 7 .. Message not acknowledged (active)
  
- 9 .. Warning acknowledged (inactive)
- 11 .. Warning acknowledged (active)
- 13 .. Warning not acknowledged (inactive)
- 15 .. Warning not acknowledged (active)
  
- 17 .. Alarm acknowledged (inactive)
- 19 .. Alarm acknowledged (active)
- 21 .. Alarm not acknowledged (inactive)
- 23 .. Alarm not acknowledged (active)
  
- 25 .. Alarm and warning acknowledged (inactive)
- 27 .. Alarm and warning acknowledged (active)
- 29 .. Alarm and warning not acknowledged (inactive)
- 31 .. Alarm and warning not acknowledged (active)

The terms 'acknowledged' and 'not acknowledged' define, if the reset-push-button on the Hiromatic E has been pressed once in order to silence the buzzer or if the 'Alarm Acknowledge' command has been performed by BMS in order to silence the buzzer.

The terms 'active' and 'inactive' define, if the alarm, warning or message is still active, which means that after performing an alarm-reset (either by sending the appropriate command via the Modbus-network or by pressing the reset-push-button on the Hiromatic E a second time) the alarm or warning will be reported again.

### Unit Status (Input Register #8):

This item holds a value, which represents the current system-state of the whole system and of the single MICROFACE boards. The values correspond to the following states:

- 0 .. Alarm Off
- 1 .. Manual
- 2 .. Local Off
- 3 .. System Off
- 4 .. Standby Alarm
- 5 .. Standby
- 6 .. Sleep / Off
- 7 .. System On
- 8 .. Warning On
- 9 .. Alarm On
- 10 .. Sleep



## Room Humidity (Input Registers #15), Room Temperature (Input Registers #16) and Supply Air Temperature (Input Register #17):

In case of NO Humitemp-sensor being used to measure the current room temperature and humidity, the 'Supply Air Temperature'-input-registers will hold the current room temperature and the 'Room Temperature'- and 'Room Humidity'-input-registers will be invalid.

### 3.5 Events

#### 3.5.1 Event-Registers

Starting from 'Hirolink for Modbus - V 2.85', there is the possibility to read the current state of a single event through Input-Registers, where each bit of these registers represents the state of one event:

Examples:

Input-Register #5001:  
State of MICROFACE board-events from ID 0 to 15

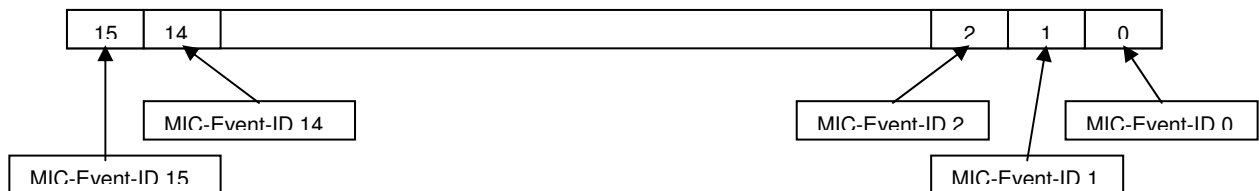

Register #	Usage
5001	MICROFACE board events #0-#15
5002	MICROFACE board events #16-#31
...	...
5008	MICROFACE board events #112-#127

The following chapter contains a list with all events available for this unit-type. Unused event-IDs will always be set to 0.

#### NOTE:

It events of type 'Message' and 'Reset' (see Event-list in the following chapter), will NOT cause a bit to be set in the Event-registers.  
Furthermore, the events 'UNIT CONNECTED' (Event-ID 100) and 'UNIT NOT CONNECTED' (Event-ID 101), which are generated by the Hirolink itself, are also NOT available as single bits within the Event-registers.

These events are only available through the 'Status Report Block' (Input registers #1 - #6) described in chapter 3.4 'Input-Register'.

**For these controls boards and its applications the event registers are upgraded only if the 'Status-Report-Acknowledge' jumper is set; so Hirolink does the upgrades mandatorily** (for more information see Modbus General Documentatio Chapter '5.4 The Status-Report').

### 3.5.2 Event-List

**IMPORTANT:**

If you intend to read the current events through the 'Status Report Block' (Input-Registers #1 - #6), please read the document 'Hirolink for Modbus V X.XX - General Documentation' (X.XX is a placeholder for the current version of the Hirolink) for a detailed description on how to use these data-points.

In the following list you can see all Events and Event-IDs available for WXG-units:

Event-ID	Event-Description	Event-Type	SW-Version
0	GENERAL ALARM	Reset	1.60+
1	AUTO RESET (Microface 1)	Message	1.60+
2	PTC 1 HIGH TEMPERATURE (Microface 1)	Warning	1.60+
3	PTC 1 LOW TEMPERATURE (Microface 1)	Warning	1.60+
4	PTC 2 HIGH TEMPERATURE (Microface 1)	Warning	1.60+
5	PTC 2 LOW TEMPERATURE (Microface 1)	Warning	1.60+
6	PTC 3 HIGH TEMPERATURE (Microface 1)	Warning	1.60+
7	PTC 3 LOW TEMPERATURE (Microface 1)	Warning	1.60+
8	PTC 4 HIGH TEMPERATURE (Microface 1)	Warning	1.60+
9	PTC 4LOW TEMPERATURE (Microface 1)	Warning	1.60+
10	PTC 5 HIGH TEMPERATURE (Microface 1)	Warning	1.60+
11	PTC 5 LOW TEMPERATURE (Microface 1)	Warning	1.60+
12	PTC 6 HIGH TEMPERATURE (Microface 1)	Warning	1.60+
13	PTC 6 LOW TEMPERATURE (Microface 1)	Warning	1.60+
14	PTC 7 HIGH TEMPERATURE (Microface 1)	Warning	1.60+
15	PTC 7 LOW TEMPERATURE (Microface 1)	Warning	1.60+
16	PTC 8 HIGH TEMPERATURE (Microface 1)	Warning	1.60+
17	PTC 8 LOW TEMPERATURE (Microface 1)	Warning	1.60+
18	HIROBUS SENSOR 1.1 HIGH VALUE (Microface 1)	Warning	1.60+
19	HIROBUS SENSOR 1.1 LOW VALUE (Microface 1)	Warning	1.60+
20	HIROBUS SENSOR 1.2 HIGH VALUE (Microface 1)	Warning	1.60+
21	HIROBUS SENSOR 1.2 LOW VALUE (Microface 1)	Warning	1.60+
22	PTC 1 SENSOR FAILURE (Microface 1)	Warning	1.60+
23	PTC 2 SENSOR FAILURE (Microface 1)	Warning	1.60+
24	PTC 3 SENSOR FAILURE (Microface 1)	Warning	1.60+
25	PTC 4 SENSOR FAILURE (Microface 1)	Warning	1.60+
26	PTC 5 SENSOR FAILURE (Microface 1)	Warning	1.60+
27	PTC 6 SENSOR FAILURE (Microface 1)	Warning	1.60+
28	PTC 7 SENSOR FAILURE (Microface 1)	Warning	1.60+
29	PTC 8 SENSOR FAILURE (Microface 1)	Warning	1.60+
30	BUS SENSOR 1 FAILURE (Microface 1)	Warning	1.60+
31	DIGITAL INPUT 1 ALARM (Microface 1)	Alarm	1.60+
32	DIGITAL INPUT 2 ALARM (Microface 1)	Alarm	1.60+
33	DIGITAL INPUT 3 ALARM (Microface 1)	Alarm	1.60+
34	DIGITAL INPUT 4 ALARM (Microface 1)	Alarm	1.60+
35	DIGITAL INPUT 5 ALARM (Microface 1)	Alarm	1.60+
36	DIGITAL INPUT 6 ALARM (Microface 1)	Alarm	1.60+
37	DIGITAL INPUT 7 ALARM (Microface 1)	Alarm	1.60+
38	DIGITAL INPUT 8 ALARM (Microface 1)	Alarm	1.60+
39	DIGITAL INPUT 9 ALARM (Microface 1)	Alarm	1.60+
40	POWER ON	Message	1.60+
41	POWER OFF	Message	1.60+
42	DIGITAL INPUT 10 ALARM (Microface 1)	Alarm	1.60+

Items for Data Gathering Panel - DGP (DIM) (Microface)

43	DIGITAL INPUT 11 ALARM (Microface 1)	Alarm	1.60+
44	DIGITAL INPUT 12 ALARM (Microface 1)	Alarm	1.60+
45	DIGITAL INPUT 13 ALARM (Microface 1)	Alarm	1.60+
46	DIGITAL INPUT 14 ALARM (Microface 1)	Alarm	1.60+
47	DIGITAL INPUT 15 ALARM (Microface 1)	Alarm	1.60+
48	DIGITAL INPUT 16 ALARM (Microface 1)	Alarm	1.60+
49	DIGITAL INPUT 17 ALARM (Microface 1)	Alarm	1.60+
50	DIGITAL INPUT 18 ALARM (Microface 1)	Alarm	1.60+
51	DIGITAL INPUT 19 ALARM (Microface 1)	Alarm	1.60+
52	DIGITAL INPUT 20 ALARM (Microface 1)	Alarm	1.60+
53	AUTO RESET (Microface 2)	Message	1.60+
54	PTC 1 HIGH TEMPERATURE (Microface 2)	Warning	1.60+
55	PTC 1 LOW TEMPERATURE (Microface 2)	Warning	1.60+
56	PTC 2 HIGH TEMPERATURE (Microface 2)	Warning	1.60+
57	PTC 2 LOW TEMPERATURE (Microface 2)	Warning	1.60+
58	PTC 3 HIGH TEMPERATURE (Microface 2)	Warning	1.60+
59	PTC 3 LOW TEMPERATURE (Microface 2)	Warning	1.60+
60	PTC 4 HIGH TEMPERATURE (Microface 2)	Warning	1.60+
61	PTC 4 LOW TEMPERATURE (Microface 2)	Warning	1.60+
62	PTC 5 HIGH TEMPERATURE (Microface 2)	Warning	1.60+
63	PTC 5 LOW TEMPERATURE (Microface 2)	Warning	1.60+
64	PTC 6 HIGH TEMPERATURE (Microface 2)	Warning	1.60+
65	PTC 6 LOW TEMPERATURE (Microface 2)	Warning	1.60+
66	PTC 7 HIGH TEMPERATURE (Microface 2)	Warning	1.60+
67	PTC 7 LOW TEMPERATURE (Microface 2)	Warning	1.60+
68	PTC 8 HIGH TEMPERATURE (Microface 2)	Warning	1.60+
69	PTC 8 LOW TEMPERATURE (Microface 2)	Warning	1.60+
70	HIROBUS SENSOR 1.1 HIGH VALUE (Microface 2)	Warning	1.60+
71	HIROBUS SENSOR 1.1 LOW VALUE (Microface 2)	Warning	1.60+
72	HIROBUS SENSOR 1.2 HIGH VALUE (Microface 2)	Warning	1.60+
73	HIROBUS SENSOR 1.2 LOW VALUE (Microface 2)	Warning	1.60+
74	PTC 1 SENSOR FAILURE (Microface 2)	Warning	1.60+
75	PTC 2 SENSOR FAILURE (Microface 2)	Warning	1.60+
76	PTC 3 SENSOR FAILURE (Microface 2)	Warning	1.60+
77	PTC 4 SENSOR FAILURE (Microface 2)	Warning	1.60+
78	PTC 5 SENSOR FAILURE (Microface 2)	Warning	1.60+
79	PTC 6 SENSOR FAILURE (Microface 2)	Warning	1.60+
80	PTC 7 SENSOR FAILURE (Microface 2)	Warning	1.60+
81	PTC 8 SENSOR FAILURE (Microface 2)	Warning	1.60+
82	BUS SENSOR 1 FAILURE (Microface 2)	Warning	1.60+
83	DIGITAL INPUT 1 ALARM (Microface 2)	Alarm	1.60+
84	DIGITAL INPUT 2 ALARM (Microface 2)	Alarm	1.60+
85	DIGITAL INPUT 3 ALARM (Microface 2)	Alarm	1.60+
86	DIGITAL INPUT 4 ALARM (Microface 2)	Alarm	1.60+
87	DIGITAL INPUT 5 ALARM (Microface 2)	Alarm	1.60+
88	DIGITAL INPUT 6 ALARM (Microface 2)	Alarm	1.60+
89	DIGITAL INPUT 7 ALARM (Microface 2)	Alarm	1.60+
90	DIGITAL INPUT 8 ALARM (Microface 2)	Alarm	1.60+
91	DIGITAL INPUT 9 ALARM (Microface 2)	Alarm	1.60+
92	DIGITAL INPUT 10 ALARM (Microface 2)	Alarm	1.60+
93	DIGITAL INPUT 11 ALARM (Microface 2)	Alarm	1.60+
94	DIGITAL INPUT 12 ALARM (Microface 2)	Alarm	1.60+
95	DIGITAL INPUT 13 ALARM (Microface 2)	Alarm	1.60+
96	DIGITAL INPUT 14 ALARM (Microface 2)	Alarm	1.60+
97	DIGITAL INPUT 15 ALARM (Microface 2)	Alarm	1.60+
98	DIGITAL INPUT 16 ALARM (Microface 2)	Alarm	1.60+

Items for Data Gathering Panel - DGP (DIM) (Microface)

99	DIGITAL INPUT 17 ALARM (Microface 2)	Alarm	1.60+
102	DIGITAL INPUT 20 ALARM (Microface 2)	Alarm	1.60+
103	AUTO RESET (Microface 3)	Message	1.60+
104	PTC 1 HIGH TEMPERATURE (Microface 3)	Warning	1.60+
105	PTC 1 LOW TEMPERATURE (Microface 3)	Warning	1.60+
106	PTC 2 HIGH TEMPERATURE (Microface 3)	Warning	1.60+
107	PTC 2 LOW TEMPERATURE (Microface 3)	Warning	1.60+
108	PTC 3 HIGH TEMPERATURE (Microface 3)	Warning	1.60+
109	PTC 3 LOW TEMPERATURE (Microface 3)	Warning	1.60+
110	PTC 4 HIGH TEMPERATURE (Microface 3)	Warning	1.60+
111	PTC 4LOW TEMPERATURE (Microface 3)	Warning	1.60+
112	PTC 5 HIGH TEMPERATURE (Microface 3)	Warning	1.60+
113	PTC 5 LOW TEMPERATURE (Microface 3)	Warning	1.60+
114	PTC 6 HIGH TEMPERATURE (Microface 3)	Warning	1.60+
115	PTC 6 LOW TEMPERATURE (Microface 3)	Warning	1.60+
116	PTC 7 HIGH TEMPERATURE (Microface 3)	Warning	1.60+
117	PTC 7 LOW TEMPERATURE (Microface 3)	Warning	1.60+
118	PTC 8 HIGH TEMPERATURE (Microface 3)	Warning	1.60+
119	PTC 8 LOW TEMPERATURE (Microface 3)	Warning	1.60+
120	HIROBUS SENSOR 1.1 HIGH VALUE (Microface 3)	Warning	1.60+
121	HIROBUS SENSOR 1.1 LOW VALUE (Microface 3)	Warning	1.60+
122	HIROBUS SENSOR 1.2 HIGH VALUE (Microface 3)	Warning	1.60+
123	HIROBUS SENSOR 1.2 LOW VALUE (Microface 3)	Warning	1.60+
124	PTC 1 SENSOR FAILURE (Microface 3)	Warning	1.60+
125	PTC 2 SENSOR FAILURE (Microface 3)	Warning	1.60+
126	PTC 3 SENSOR FAILURE (Microface 3)	Warning	1.60+
127	PTC 4 SENSOR FAILURE (Microface 3)	Warning	1.60+
128	PTC 5 SENSOR FAILURE (Microface 3)	Warning	1.60+
129	PTC 6 SENSOR FAILURE (Microface 3)	Warning	1.60+
130	PTC 7 SENSOR FAILURE (Microface 3)	Warning	1.60+
131	PTC 8 SENSOR FAILURE (Microface 3)	Warning	1.60+
132	BUS SENSOR 1 FAILURE (Microface 3)	Warning	1.60+
133	DIGITAL INPUT 1 ALARM (Microface 3)	Alarm	1.60+
134	DIGITAL INPUT 2 ALARM (Microface 3)	Alarm	1.60+
135	DIGITAL INPUT 3 ALARM (Microface 3)	Alarm	1.60+
136	DIGITAL INPUT 4 ALARM (Microface 3)	Alarm	1.60+
137	DIGITAL INPUT 5 ALARM (Microface 3)	Alarm	1.60+
138	DIGITAL INPUT 6 ALARM (Microface 3)	Alarm	1.60+
139	DIGITAL INPUT 7 ALARM (Microface 3)	Alarm	1.60+
140	DIGITAL INPUT 8 ALARM (Microface 3)	Alarm	1.60+
141	DIGITAL INPUT 9 ALARM (Microface 3)	Alarm	1.60+
142	DIGITAL INPUT 10 ALARM (Microface 3)	Alarm	1.60+
143	DIGITAL INPUT 11 ALARM (Microface 3)	Alarm	1.60+
144	DIGITAL INPUT 12 ALARM (Microface 3)	Alarm	1.60+
145	DIGITAL INPUT 13 ALARM (Microface 3)	Alarm	1.60+
146	DIGITAL INPUT 14 ALARM (Microface 3)	Alarm	1.60+
147	DIGITAL INPUT 15 ALARM (Microface 3)	Alarm	1.60+
148	DIGITAL INPUT 16 ALARM (Microface 3)	Alarm	1.60+
149	DIGITAL INPUT 17 ALARM (Microface 3)	Alarm	1.60+
150	DIGITAL INPUT 18 ALARM (Microface 3)	Alarm	1.60+
151	DIGITAL INPUT 19 ALARM (Microface 3)	Alarm	1.60+
152	DIGITAL INPUT 20 ALARM (Microface 3)	Alarm	1.60+
153	AUTO RESET (Microface 4)	Message	1.60+
154	PTC 1 HIGH TEMPERATURE (Microface 4)	Warning	1.60+
155	PTC 1 LOW TEMPERATURE (Microface 4)	Warning	1.60+
156	PTC 2 HIGH TEMPERATURE (Microface 4)	Warning	1.60+

Items for Data Gathering Panel - DGP (DIM) (Microface)

157	PTC 2 LOW TEMPERATURE (Microface 4)	Warning	1.60+
158	PTC 3 HIGH TEMPERATURE (Microface 4)	Warning	1.60+
159	PTC 3 LOW TEMPERATURE (Microface 4)	Warning	1.60+
160	PTC 4 HIGH TEMPERATURE (Microface 4)	Warning	1.60+
161	PTC 4LOW TEMPERATURE (Microface 4)	Warning	1.60+
162	PTC 5 HIGH TEMPERATURE (Microface 4)	Warning	1.60+
163	PTC 5 LOW TEMPERATURE (Microface 4)	Warning	1.60+
164	PTC 6 HIGH TEMPERATURE (Microface 4)	Warning	1.60+
165	PTC 6 LOW TEMPERATURE (Microface 4)	Warning	1.60+
166	PTC 7 HIGH TEMPERATURE (Microface 4)	Warning	1.60+
167	PTC 7 LOW TEMPERATURE (Microface 4)	Warning	1.60+
168	PTC 8 HIGH TEMPERATURE (Microface 4)	Warning	1.60+
169	PTC 8 LOW TEMPERATURE (Microface 4)	Warning	1.60+
170	HIROBUS SENSOR 1.1 HIGH VALUE (Microface 4)	Warning	1.60+
171	HIROBUS SENSOR 1.1 LOW VALUE (Microface 4)	Warning	1.60+
172	HIROBUS SENSOR 1.2 HIGH VALUE (Microface 4)	Warning	1.60+
173	HIROBUS SENSOR 1.2 LOW VALUE (Microface 4)	Warning	1.60+
174	PTC 1 SENSOR FAILURE (Microface 4)	Warning	1.60+
175	PTC 2 SENSOR FAILURE (Microface 4)	Warning	1.60+
176	PTC 3 SENSOR FAILURE (Microface 4)	Warning	1.60+
177	PTC 4 SENSOR FAILURE (Microface 4)	Warning	1.60+
178	PTC 5 SENSOR FAILURE (Microface 4)	Warning	1.60+
179	PTC 6 SENSOR FAILURE (Microface 4)	Warning	1.60+
180	PTC 7 SENSOR FAILURE (Microface 4)	Warning	1.60+
181	PTC 8 SENSOR FAILURE (Microface 4)	Warning	1.60+
182	BUS SENSOR 1 FAILURE (Microface 4)	Warning	1.60+
183	DIGITAL INPUT 1 ALARM (Microface 4)	Alarm	1.60+
184	DIGITAL INPUT 2 ALARM (Microface 4)	Alarm	1.60+
185	DIGITAL INPUT 3 ALARM (Microface 4)	Alarm	1.60+
186	DIGITAL INPUT 4 ALARM (Microface 4)	Alarm	1.60+
187	DIGITAL INPUT 5 ALARM (Microface 4)	Alarm	1.60+
188	DIGITAL INPUT 6 ALARM (Microface 4)	Alarm	1.60+
189	DIGITAL INPUT 7 ALARM (Microface 4)	Alarm	1.60+
190	DIGITAL INPUT 8 ALARM (Microface 4)	Alarm	1.60+
191	DIGITAL INPUT 9 ALARM (Microface 4)	Alarm	1.60+
192	DIGITAL INPUT 10 ALARM (Microface 4)	Alarm	1.60+
193	DIGITAL INPUT 11 ALARM (Microface 4)	Alarm	1.60+
194	DIGITAL INPUT 12 ALARM (Microface 4)	Alarm	1.60+
195	DIGITAL INPUT 13 ALARM (Microface 4)	Alarm	1.60+
196	DIGITAL INPUT 14 ALARM (Microface 4)	Alarm	1.60+
197	DIGITAL INPUT 15 ALARM (Microface 4)	Alarm	1.60+
198	DIGITAL INPUT 16 ALARM (Microface 4)	Alarm	1.60+
199	DIGITAL INPUT 17 ALARM (Microface 4)	Alarm	1.60+
200	DIGITAL INPUT 18 ALARM (Microface 4)	Alarm	1.60+
201	DIGITAL INPUT 19 ALARM (Microface 4)	Alarm	1.60+
202	DIGITAL INPUT 20 ALARM (Microface 4)	Alarm	1.60+
203	AUTO RESET (Microface 5)	Message	1.60+
204	PTC 1 HIGH TEMPERATURE (Microface 5)	Warning	1.60+
205	PTC 1 LOW TEMPERATURE (Microface 5)	Warning	1.60+
206	PTC 2 HIGH TEMPERATURE (Microface 5)	Warning	1.60+
207	PTC 2 LOW TEMPERATURE (Microface 5)	Warning	1.60+
208	PTC 3 HIGH TEMPERATURE (Microface 5)	Warning	1.60+
209	PTC 3 LOW TEMPERATURE (Microface 5)	Warning	1.60+
210	PTC 4 HIGH TEMPERATURE (Microface 5)	Warning	1.60+
211	PTC 4LOW TEMPERATURE (Microface 5)	Warning	1.60+
212	PTC 5 HIGH TEMPERATURE (Microface 5)	Warning	1.60+

Items for Data Gathering Panel - DGP (DIM) (Microface)

213	PTC 5 LOW TEMPERATURE (Microface 5)	Warning	1.60+
214	PTC 6 HIGH TEMPERATURE (Microface 5)	Warning	1.60+
215	PTC 6 LOW TEMPERATURE (Microface 5)	Warning	1.60+
216	PTC 7 HIGH TEMPERATURE (Microface 5)	Warning	1.60+
217	PTC 7 LOW TEMPERATURE (Microface 5)	Warning	1.60+
218	PTC 8 HIGH TEMPERATURE (Microface 5)	Warning	1.60+
219	PTC 8 LOW TEMPERATURE (Microface 5)	Warning	1.60+
220	HIROBUS SENSOR 1.1 HIGH VALUE (Microface 5)	Warning	1.60+
221	HIROBUS SENSOR 1.1 LOW VALUE (Microface 5)	Warning	1.60+
222	HIROBUS SENSOR 1.2 HIGH VALUE (Microface 5)	Warning	1.60+
223	HIROBUS SENSOR 1.2 LOW VALUE (Microface 5)	Warning	1.60+
224	PTC 1 SENSOR FAILURE (Microface 5)	Warning	1.60+
225	PTC 2 SENSOR FAILURE (Microface 5)	Warning	1.60+
226	PTC 3 SENSOR FAILURE (Microface 5)	Warning	1.60+
227	PTC 4 SENSOR FAILURE (Microface 5)	Warning	1.60+
228	PTC 5 SENSOR FAILURE (Microface 5)	Warning	1.60+
229	PTC 6 SENSOR FAILURE (Microface 5)	Warning	1.60+
230	PTC 7 SENSOR FAILURE (Microface 5)	Warning	1.60+
231	PTC 8 SENSOR FAILURE (Microface 5)	Warning	1.60+
232	BUS SENSOR 1 FAILURE (Microface 5)	Warning	1.60+
233	DIGITAL INPUT 1 ALARM (Microface 5)	Alarm	1.60+
234	DIGITAL INPUT 2 ALARM (Microface 5)	Alarm	1.60+
235	DIGITAL INPUT 3 ALARM (Microface 5)	Alarm	1.60+
236	DIGITAL INPUT 4 ALARM (Microface 5)	Alarm	1.60+
237	DIGITAL INPUT 5 ALARM (Microface 5)	Alarm	1.60+
238	DIGITAL INPUT 6 ALARM (Microface 5)	Alarm	1.60+
239	DIGITAL INPUT 7 ALARM (Microface 5)	Alarm	1.60+
240	DIGITAL INPUT 8 ALARM (Microface 5)	Alarm	1.60+
241	DIGITAL INPUT 9 ALARM (Microface 5)	Alarm	1.60+
242	DIGITAL INPUT 10 ALARM (Microface 5)	Alarm	1.60+
243	DIGITAL INPUT 11 ALARM (Microface 5)	Alarm	1.60+
244	DIGITAL INPUT 12 ALARM (Microface 5)	Alarm	1.60+
245	DIGITAL INPUT 13 ALARM (Microface 5)	Alarm	1.60+
246	DIGITAL INPUT 14 ALARM (Microface 5)	Alarm	1.60+
247	DIGITAL INPUT 15 ALARM (Microface 5)	Alarm	1.60+
248	DIGITAL INPUT 16 ALARM (Microface 5)	Alarm	1.60+
249	DIGITAL INPUT 17 ALARM (Microface 5)	Alarm	1.60+
250	DIGITAL INPUT 18 ALARM (Microface 5)	Alarm	1.60+
251	DIGITAL INPUT 19 ALARM (Microface 5)	Alarm	1.60+
252	DIGITAL INPUT 20 ALARM (Microface 5)	Alarm	1.60+
253	DIGITAL INPUT 18 ALARM (Microface 2)	Alarm	1.60+
254	DIGITAL INPUT 19 ALARM (Microface 2)	Alarm	1.60+
179	PTC 6 SENSOR FAILURE (Microface 4)	Warning	1.60+
180	PTC 7 SENSOR FAILURE (Microface 4)	Warning	1.60+
181	PTC 8 SENSOR FAILURE (Microface 4)	Warning	1.60+
182	BUS SENSOR 1 FAILURE (Microface 4)	Warning	1.60+
183	DIGITAL INPUT 1 ALARM (Microface 4)	Alarm	1.60+
184	DIGITAL INPUT 2 ALARM (Microface 4)	Alarm	1.60+
185	DIGITAL INPUT 3 ALARM (Microface 4)	Alarm	1.60+
186	DIGITAL INPUT 4 ALARM (Microface 4)	Alarm	1.60+
187	DIGITAL INPUT 5 ALARM (Microface 4)	Alarm	1.60+
188	DIGITAL INPUT 6 ALARM (Microface 4)	Alarm	1.60+
189	DIGITAL INPUT 7 ALARM (Microface 4)	Alarm	1.60+
190	DIGITAL INPUT 8 ALARM (Microface 4)	Alarm	1.60+
191	DIGITAL INPUT 9 ALARM (Microface 4)	Alarm	1.60+
192	DIGITAL INPUT 10 ALARM (Microface 4)	Alarm	1.60+

Items for Data Gathering Panel - DGP (DIM) (Microface)

193	DIGITAL INPUT 11 ALARM (Microface 4)	Alarm	1.60+
194	DIGITAL INPUT 12 ALARM (Microface 4)	Alarm	1.60+
195	DIGITAL INPUT 13 ALARM (Microface 4)	Alarm	1.60+
196	DIGITAL INPUT 14 ALARM (Microface 4)	Alarm	1.60+
197	DIGITAL INPUT 15 ALARM (Microface 4)	Alarm	1.60+
198	DIGITAL INPUT 16 ALARM (Microface 4)	Alarm	1.60+
199	DIGITAL INPUT 17 ALARM (Microface 4)	Alarm	1.60+
200	DIGITAL INPUT 18 ALARM (Microface 4)	Alarm	1.60+
201	DIGITAL INPUT 19 ALARM (Microface 4)	Alarm	1.60+
202	DIGITAL INPUT 20 ALARM (Microface 4)	Alarm	1.60+
203	AUTO RESET (Microface 5)	Message	1.60+
204	PTC 1 HIGH TEMPERATURE (Microface 5)	Warning	1.60+
205	PTC 1 LOW TEMPERATURE (Microface 5)	Warning	1.60+
206	PTC 2 HIGH TEMPERATURE (Microface 5)	Warning	1.60+
207	PTC 2 LOW TEMPERATURE (Microface 5)	Warning	1.60+
208	PTC 3 HIGH TEMPERATURE (Microface 5)	Warning	1.60+
209	PTC 3 LOW TEMPERATURE (Microface 5)	Warning	1.60+
210	PTC 4 HIGH TEMPERATURE (Microface 5)	Warning	1.60+
211	PTC 4LOW TEMPERATURE (Microface 5)	Warning	1.60+
212	PTC 5 HIGH TEMPERATURE (Microface 5)	Warning	1.60+
213	PTC 5 LOW TEMPERATURE (Microface 5)	Warning	1.60+
214	PTC 6 HIGH TEMPERATURE (Microface 5)	Warning	1.60+
215	PTC 6 LOW TEMPERATURE (Microface 5)	Warning	1.60+
216	PTC 7 HIGH TEMPERATURE (Microface 5)	Warning	1.60+
217	PTC 7 LOW TEMPERATURE (Microface 5)	Warning	1.60+
218	PTC 8 HIGH TEMPERATURE (Microface 5)	Warning	1.60+
219	PTC 8 LOW TEMPERATURE (Microface 5)	Warning	1.60+
220	HIROBUS SENSOR 1.1 HIGH VALUE (Microface 5)	Warning	1.60+
221	HIROBUS SENSOR 1.1 LOW VALUE (Microface 5)	Warning	1.60+
222	HIROBUS SENSOR 1.2 HIGH VALUE (Microface 5)	Warning	1.60+
223	HIROBUS SENSOR 1.2 LOW VALUE (Microface 5)	Warning	1.60+
224	PTC 1 SENSOR FAILURE (Microface 5)	Warning	1.60+
225	PTC 2 SENSOR FAILURE (Microface 5)	Warning	1.60+
226	PTC 3 SENSOR FAILURE (Microface 5)	Warning	1.60+
227	PTC 4 SENSOR FAILURE (Microface 5)	Warning	1.60+
228	PTC 5 SENSOR FAILURE (Microface 5)	Warning	1.60+
229	PTC 6 SENSOR FAILURE (Microface 5)	Warning	1.60+
230	PTC 7 SENSOR FAILURE (Microface 5)	Warning	1.60+
231	PTC 8 SENSOR FAILURE (Microface 5)	Warning	1.60+
232	BUS SENSOR 1 FAILURE (Microface 5)	Warning	1.60+
233	DIGITAL INPUT 1 ALARM (Microface 5)	Alarm	1.60+
234	DIGITAL INPUT 2 ALARM (Microface 5)	Alarm	1.60+
235	DIGITAL INPUT 3 ALARM (Microface 5)	Alarm	1.60+
236	DIGITAL INPUT 4 ALARM (Microface 5)	Alarm	1.60+
237	DIGITAL INPUT 5 ALARM (Microface 5)	Alarm	1.60+
237	DIGITAL INPUT 5 ALARM (Microface 5)	Alarm	1.60+
238	DIGITAL INPUT 6 ALARM (Microface 5)	Alarm	1.60+
239	DIGITAL INPUT 7 ALARM (Microface 5)	Alarm	1.60+
240	DIGITAL INPUT 8 ALARM (Microface 5)	Alarm	1.60+
241	DIGITAL INPUT 9 ALARM (Microface 5)	Alarm	1.60+
242	DIGITAL INPUT 10 ALARM (Microface 5)	Alarm	1.60+
243	DIGITAL INPUT 11 ALARM (Microface 5)	Alarm	1.60+
244	DIGITAL INPUT 12 ALARM (Microface 5)	Alarm	1.60+
245	DIGITAL INPUT 13 ALARM (Microface 5)	Alarm	1.60+
246	DIGITAL INPUT 14 ALARM (Microface 5)	Alarm	1.60+
247	DIGITAL INPUT 15 ALARM (Microface 5)	Alarm	1.60+

Items for Data Gathering Panel - DGP (DIM) (Microface)

248	DIGITAL INPUT 16 ALARM (Microface 5)	Alarm	1.60+
249	DIGITAL INPUT 17 ALARM (Microface 5)	Alarm	1.60+
250	DIGITAL INPUT 18 ALARM (Microface 5)	Alarm	1.60+
251	DIGITAL INPUT 19 ALARM (Microface 5)	Alarm	1.60+
252	DIGITAL INPUT 20 ALARM (Microface 5)	Alarm	1.60+
253	DIGITAL INPUT 18 ALARM (Microface 2)	Alarm	1.60+
254	DIGITAL INPUT 19 ALARM (Microface 2)	Alarm	1.60+
100	UNIT CONNECTED	Message	1.60+
101	UNIT NOT CONNECTED	Message	1.60+



## ***A.Document-Changes***

This appendix contains all changes that have been applied to this document up to the current version:

This is the first version of this document.

## Connectivity



*the evolution*

## Hirolink for Modbus

(18) Items for RACK (RKE) (Microface).doc

English

27/03/07 Release 1.00E

1. INTRODUCTION RACK (RKE) (MICROFACE) ..... 3

2. COMPATIBILITY-LIST ..... 3

3. ITEMS FOR RACK (RKE) (MICROFACE) ..... 4

    3.1 COILS..... 4

    3.2 INPUT-STATUS..... 4

    3.3 HOLDING REGISTER ..... 5

    3.4 INPUT-REGISTER ..... 7

    3.5 EVENTS..... 9

        3.5.1 *Event-Registers*..... 9

        3.5.2 *Event-List*..... 10

4. DOCUMENT-CHANGES ..... 11

## 1. Introduction RACK (RKE) (Microface)

This document contains a description of all data-points that are available via the 'Hirolink for Modbus' from this type of air-conditioner.

### **IMPORTANT:**

It is vital to the correct integration of the Hirolink into a Modbus-network, that you have read and understood the topics described in the document 'Hirolink for Modbus V X.XX - General Documentation' (X.XX is a placeholder for the current version of the Hirolink). So, if you haven't read this document until now, read it first.

## 2. Compatibility-List

Before connecting a Hiromatic to the Modbus-Hirolink you must check, if the Hiromatic-software-version is compatible with this version of the Hirolink.

You can do this by checking the labels on the eproms, which are inserted into the Hiromatic and the Microface. The eprom inserted in the Hiromatic must be called RKE + Version-Number (e.g.RKE160).

To make sure that the label on the eproms is correct, you should also check the version-information, that the Hiromatic displays shortly after start-up.

The important information in this window is only the software-version and the software-date (note that the date-format is mm/dd/yy). Make sure that the software-version installed in your installation matches one of the compatible versions listed below:

<i>Version</i>	<i>Date</i>
1.60.xxx	---

### 3. Items for RACK (RKE) (Microface)

According to the Modbus-protocol-specifications the values and parameters provided by the Hiromatic are represented in 4 groups:

- Coils: Used for changeable, digital values
- Inputs: Used for not changeable, digital values
- Holding Registers: Used for changeable, analog values
- Input Registers: Used for not changeable, analog values

This Hirolink can be compatible with more than one version of this Hiromatic-type and it is possible that there have been extensions in the number of available items from one version to the next.

Therefore the column 'SW-Version' contained in the following lists provides information about the availability of each item depending on the Hiromatic-software-version. For example a entry like '1.15+' means, that this item is available from Hiromatics with software-version 1.15 and higher.

#### **IMPORTANT:**

The available data-points shown in the following chapters are numbered starting from 1, according to the Modbus-Protocol-Specification. Still some BMS start numbering the data-points from 0.

So, in case that the BMS you are using starts numbering from 0, you have to decrease the listed numbers by 1.

#### **3.1 Coils**

Not used on this Hiromatic-type.

#### **3.2 Input-Status**

Not used on this Hiromatic-type.

### 3.3 Holding Register

Register #	Usage	Range; Unit	SW-Version
1	Status Report Acknowledged	See explanation below	1.60+
2	HM-System On/Off	0 -> Hiromatic System Off; 1 -> Hiromatic System On	1.60+
3 - 18	Single Alarm (MIC 1-16)	See explanation below	1.60+
35 - 50	High Outlet Temperature level 3 (MIC1-16)	0 -> Single Unit System Off; 1 -> Single Unit System On	1.60+
51 - 66	High Inlet Temperature level 1 (MIC1-16)	0 -> No, 1 - 99;	1.60+
67 - 82	High Inlet Temperature level 2 (MIC1-16)	0 -> No, 1 - 99;	1.60+
83 - 98	High Inlet Temperature level 3 (MIC1-16)	0 -> No, 1 - 99;	1.60+
259 - 274	High Delta Temperature level 2 (MIC1-16)	0 -> No, 1 - 99;	1.60+
275 - 290	High Delta Temperature level 1 (MIC1-16)	0 -> No, 1 - 99;	1.60+
291 - 306	High Outlet Temperature level 2 (MIC1-16)	0 -> No, 1 - 99;	1.60+
307 - 322	High Outlet Temperature level 1 (MIC1-16)	0 -> No, 1 - 99;	1.60+
499 - 514	High Delta Temperature level 3 (MIC1-16)	0 -> No, 1 - 99;	1.60+

#### Status-Report-Acknowledge (Holding Register #1):

Read the document 'Hirolink for Modbus V X.XX - General Documentation' (X.XX is a placeholder for the current version of the Hirolink) for a description on how to use this data-point.

#### Single Alarm-Status (Holding Registers #3 - #18):

This item holds a value which represents the current alarm-state of single Microface.

It can be written to in order to perform either a 'Alarm Acknowledge'- or a 'Alarm Reset'-command on a single Microface:

##### 2 .. Alarm Reset:

This command will reset all alarms, warnings and messages currently present on a Microface. As a consequence alarms, warnings and messages that are inactive will disappear, will active alarms, warnings and messages will be reported again.

##### 4 .. Alarm Acknowledge:

This command will acknowledge all alarms, warnings and messages present on a Microface. As a consequence alarms, warnings and messages that were in an unacknowledged state will be acknowledged after the command.

When read, the value corresponds to the following states:

0 .. No alarm present

1 .. Message acknowledged (inactive)

3 .. Message acknowledged (active)

5 .. Message not acknowledged (inactive)

7 .. Message not acknowledged (active)

9 .. Warning acknowledged (inactive)

11.. Warning acknowledged (active)

13.. Warning not acknowledged (inactive)

15.. Warning not acknowledged (active)

- 17.. Alarm acknowledged (inactive)
- 19.. Alarm acknowledged (active)
- 21...Alarm not acknowledged (inactive)
- 23.. Alarm not acknowledged (active)
  
- 25.. Alarm and warning acknowledged (inactive)
- 27.. Alarm and warning acknowledged (active)
- 29.. Alarm and warning not acknowledged (inactive)
- 31.. Alarm and warning not acknowledged (active)

The terms 'acknowledged' and 'not acknowledged' define, if the reset-push-button on the Hiromatic has been pressed once in order to silence the buzzer or if the command 'Alarm Acknowledge' has been performed.

The terms 'active' and 'inactive' define, if the alarm, warning or message is still active, which means that after performing a alarm-reset (either by sending the appropriate command via the Modbus-network or by pressing the reset-push-button on the Hiromatic a second time) the alarm or warning will be reported again.

**NOTE:**

Although you can read the alarm-state of the whole system, it is not possible to issue a 'Alarm Acknowledge'- or 'Alarm Reset'-command for the whole system. Instead you have to issue these commands for each Microface separately.

### 3.4 Input-Register

Register #	Usage	Range; Unit	SW-Version
1	Event-ID	ID identifying the event	1.60+
2	Controller-ID	Controller-ID, where the event occurred	1.60+
3	Minute	Minute, when event occurred	1.60+
4	Hour	Hour, when event occurred	1.60+
5	Date	Date, when event occurred	1.60+
6	Event-Type	0 -> message, 1 -> warning, 2 -> alarm, 3 and 4 -> reset	1.60+
7	System Alarm	See explanation below	1.60+
8	System Status	See explanation below	1.60+
121	Average of all Racks Inlet Temperature	-300 - 1000; [1/10 °C]	1.60+
201-216	Rack Outlet Temperature (MIC1-16)	-300 - 1000; [1/10 °C]; see explanation below	1.60+
233-248	Rack Inlet Temperature (MIC1-16)	-300 - 1000; [1/10 °C]; see explanation below	1.60+
281	Average of all Racks Outlet Temperature	-300 - 1000; [1/10 °C]	1.60+
297-312	Rack Inlet DX Temperature (MIC1-16)	-300 - 1000; [1/10 °C]	1.60+
329-344	Rack Inlet SX Temperature (MIC1-16)	-300 - 1000; [1/10 °C]	1.60+

#### Status-Report-Block (Input Register #1 - #6):

Read the document 'Hirolink for Modbus V X.XX - General Documentation' (X.XX is a placeholder for the current version of the Hirolink) for a description on how to use these data-points.

#### System-Alarm (Input Register #7):

This item holds a value, which represents the current alarm-state of the whole system. This alarm-state is calculated from the single alarm-states of each Microface and holds the highest of those alarm-states. The single alarm-states can be read using the appropriate Holding Registers.

The values correspond to the following states:

- 0 .. No alarm present
- 1 .. Message acknowledged (inactive)
- 3 .. Message acknowledged (active)
- 5 .. Message not acknowledged (inactive)
- 7 .. Message not acknowledged (active)
  
- 9 .. Warning acknowledged (inactive)
- 11 .. Warning acknowledged (active)
- 13 .. Warning not acknowledged (inactive)
- 15 .. Warning not acknowledged (active)
  
- 17 .. Alarm acknowledged (inactive)
- 19 .. Alarm acknowledged (active)
- 21 .. Alarm not acknowledged (inactive)
- 23 .. Alarm not acknowledged (active)
  
- 25 .. Alarm and warning acknowledged (inactive)
- 27 .. Alarm and warning acknowledged (active)
- 29 .. Alarm and warning not acknowledged (inactive)
- 31 .. Alarm and warning not acknowledged (active)

The terms 'acknowledged' and 'not acknowledged' define, if the reset-push-button on the Hiromatic has been pressed once in order to silence the buzzer or if the command 'Alarm Acknowledge' has been performed.



The terms 'active' and 'inactive' define, if the alarm, warning or message is still active, which means that after performing a alarm-reset (either by sending the appropriate command via the Modbus-network or by pressing the reset-push-button on the Hiromatic a second time) the alarm or warning will be reported again.

### System-Status (Input Register #8) and Single Status (Input Registers #137 - #152):

This item holds a value, which represents the current system-state of the whole system and of the single Microfaces. The values correspond to the following states:

- 0 .. Alarm Off
- 1 .. Manual
- 2 .. Local Off
- 3 .. System Off
- 4 .. Standby Alarm
- 5 .. Standby
- 6 .. Sleep / Off
- 7 .. System On
- 8 .. Warning On
- 9 .. Alarm On
- 10 .. Sleep

### Supply Air Temperature (Input Register #201 - #216), Room Temperature (Input Registers #233 - #248):

In case of NO Humitemp-sensor being used to measure the current room temperature and humidity, the 'Supply Air Temperature'-input-registers will hold the current room temperature and the 'Room Temperature'- and 'Room Humidity'-input-registers will be invalid. With Hirolink for MODBUS V 2.88, starting from the E1G and EVG EPROM applications, in case of no Humitemp, the ambient temperature can be read both in Supply Air Temperature (Input Register #201 - #216), Room Temperature (Input Registers #233 - #248) registers.

### 3.5 Events

#### 3.5.1 Event-Registers

Starting from 'HL for Modbus - V 2.85', there is the possibility to read the current state of a single event through Input-Registers, each bit of these registers represents the state of one event:  
Examples:

Input-Register #5001:

State of Hiromatic-events from ID 0 to 15

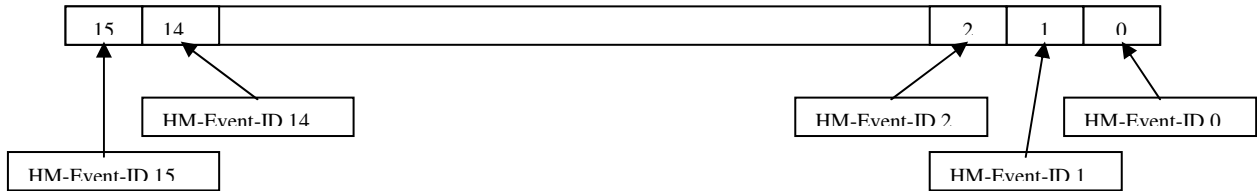

Input-Register #5009:

State of Microface-events from ID 0 to 15 from Microface with ID #1

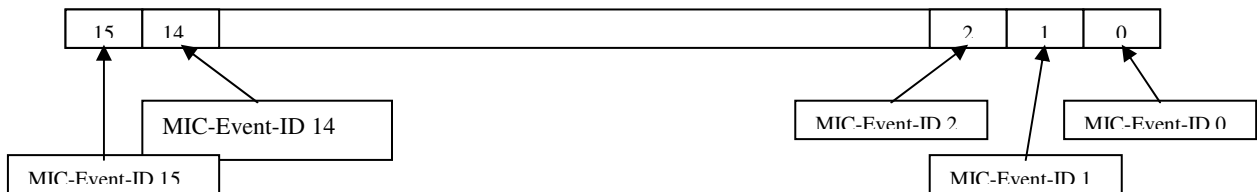

Register #	Usage
5001	Hiromatic-events #0-#15
5002	Hiromatic-events #16-#31
...	...
5008	Hiromatic-events #112-#127
5009	Microface #1-events #0-#15
5010	Microface #1-events #16-#31
...	...
5016	Microface #1-events #112-#127
5017	Microface #2-events #0-#15
5018	Microface #2-events #16-#31
...	...
5024	Microface #2-events #112-#127
...	...
5129	Microface #16-events #0-#15
5130	Microface #16-events #16-#31
...	...
5136	Microface #16-events #112-#127

The following chapter contains a list with all events available for this unit-type. Unused event-IDs will always be set to 0.

**NOTE:**

Events of type 'Message' and 'Reset' (see Event-list in the following chapter), will NOT cause a bit to be set in the Event-registers when they are reported by the Hiromatic. Furthermore, the events 'UNIT CONNECTED' (Event-ID 100) and 'UNIT NOT CONNECTED' (Event-ID 101), which are generated by the Hirolink itself, are also NOT available as single bits within the Event-registers.

These events are only available through the 'Status Report Block' (Input registers #1 - #6).

**For these controls boards and its applications the event registers are upgraded only if the 'Status-Report-Acknowledge' jumper is set; so Hirolink does the upgrades mandatory** (for more information see Modbus General Documentation Chapter '5.4 The Status-Report').

### 3.5.2 Event-List

#### **IMPORTANT:**

If you intend to read the current events through the 'Status Report Block' (Input-Registers #1 -#6), please read the document 'Hirolink for Modbus V X.XX - General Documentation' (X.XX is a placeholder for the current version of the Hirolink) for a detailed description on how to use these data-points.

In the following list you can see all Events and Event-IDs available for WXG-units:

Event-ID	Event-Description	Event-Type	SW-Version
0	GENERAL ALARM	Reset	1.60+
3	High Delta Temperature 3	Alarm	1.60+
6	High Delta Temperature 1	Warning	1.60+
7	High Delta Temperature 2	Alarm	1.60+
8	Smoke Alarm	Alarm	1.60+
9	Rear Door Open	Warning	1.60+
10	Front Door Open	Warning	1.60+
12	Backup Cooling Active	Alarm	1.60+
15	Fire Detection Failure	Warning	1.60+
18	High Outlet Temperature Level 1	Warning	1.60+
19	High Outlet Temperature Level 2	Alarm	1.60+
22	High Inlet Temperature Level 1	Warning	1.60+
23	High Inlet Temperature Level 2	Alarm	1.60+
24	High Inlet Temperature Level 3	Alarm	1.60+
25	High Outlet Temperature Level 3	Alarm	1.60+
29	Outlet Sensor Failure	Warning	1.60+
61	Inlet SX Sensor Failure	Warning	1.60+
62	Inlet DX Sensor Failure	Warning	1.60+
65	Smoke Warning	Warning	1.60+
73	Fire Alarm	Alarm	1.60+

100	UNIT CONNECTED	Message	1.60+
101	UNIT NOT CONNECTED	Message	1.60+

## 4. Document-Changes

This appendix contains all changes that have been applied to this document up to the current version:

This is the first version of this document.

## Connectivity

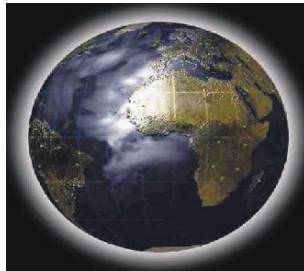

*the evolution*

## Hirolink for Modbus

(19) Items for XDFN (XDE) (Microface).doc

English

06/04/07 Release 1.00E

<b>1.</b>	<b>INTRODUCTION XDFN (XDE) (MICROFACE)</b> .....	<b>3</b>
<b>2.</b>	<b>COMPATIBILITY-LIST</b> .....	<b>3</b>
<b>3.</b>	<b>ITEMS FOR XDFN (XDE) (MICROFACE)</b> .....	<b>4</b>
3.1	COILS.....	4
3.2	INPUT-STATUS.....	4
3.3	HOLDING REGISTER.....	5
3.4	INPUT-REGISTER .....	7
3.5	EVENTS.....	9
3.5.1	<i>Event-Registers</i> .....	9
3.5.2	<i>Event-List</i> .....	10
<b>4.</b>	<b>DOCUMENT-CHANGES</b> .....	<b>11</b>

## 1. Introduction XDFN (XDE) (Microface)

This document contains a description of all data-points that are available via the 'Hirolink for Modbus' from this type of air-conditioner.

### **IMPORTANT:**

It is vital to the correct integration of the Hirolink into a Modbus-network, that you have read and understood the topics described in the document 'Hirolink for Modbus V X.XX - General Documentation' (X.XX is a placeholder for the current version of the Hirolink). So, if you haven't read this document until now, read it first.

## 2. Compatibility-List

Before connecting a Hiromatic to the Modbus-Hirolink you must check, if the Hiromatic-software-version is compatible with this version of the Hirolink.

You can do this by checking the labels on the eproms, which are inserted into the Hiromatic and the Microface. The eprom inserted in the Hiromatic must be called RKE + Version-Number (e.g.RKE160).

To make sure that the label on the eproms is correct, you should also check the version-information, that the Hiromatic displays shortly after start-up.

The important information in this window is only the software-version and the software-date (note that the date-format is mm/dd/yy). Make sure that the software-version installed in your installation matches one of the compatible versions listed below:

<i>Version</i>	<i>Date</i>
1.60.xxx	---

### 3. Items for XDFN (XDE) (Microface)

According to the Modbus-protocol-specifications the values and parameters provided by the Hiromatic are represented in 4 groups:

- Coils: Used for changeable, digital values
- Inputs: Used for not changeable, digital values
- Holding Registers: Used for changeable, analog values
- Input Registers: Used for not changeable, analog values

This Hirolink can be compatible with more than one version of this Hiromatic-type and it is possible that there have been extensions in the number of available items from one version to the next.

Therefore the column 'SW-Version' contained in the following lists provides information about the availability of each item depending on the Hiromatic-software-version. For example a entry like '1.15+' means, that this item is available from Hiromatics with software-version 1.15 and higher.

#### **IMPORTANT:**

The available data-points shown in the following chapters are numbered starting from 1, according to the Modbus-Protocol-Specification. Still some BMS start numbering the data-points from 0.

So, in case that the BMS you are using starts numbering from 0, you have to decrease the listed numbers by 1.

#### **3.1 Coils**

Not used on this Hiromatic-type.

#### **3.2 Input-Status**

Not used on this Hiromatic-type.



### 3.3 Holding Register

Register #	Usage	Range; Unit	SW-Version
1	Status-Report-Acknowledge	See explanation below	1.60+
2	HM-System On/Off	0 -> Hiromatic System Off; 1 -> Hiromatic System On	1.60+
3 -18	Single Alarm-Status (MIC 1 - 16)	See explanation below	1.60+
19-34	Single Unit System On/Off (MIC 1 - 16)	0 -> Single Unit System Off; 1 -> Single Unit System On	1.60+
35-50	Heater Working Hours (MIC 1 - 16)	0 - 32000; [h]	1.60+
51-66	Humidifier Working Hours (MIC 1 - 16)	0 - 32000; [h]	1.60+
67-82	Compressor 1 Working Hours (MIC 1 - 16)	0 - 32000; [h]	1.60+
83-98	Conditioner Working Hours (MIC 1 - 16)	0 - 32000; [h]	1.60+
243-258	Low Pressure Delay Time (MIC 1 - 16)	0 - 5; [min]	1.60+
259-274	Low Humidity Warning (MIC 1 - 16)	0 -> No, 1 - 99; [%RH]	1.60+
275-290	High Humidity Warning (MIC 1 - 16)	0 -> No, 1 - 99; [%RH]	1.60+
291-306	Low Temperature Warning (MIC 1 - 16)	0 -> No, 12 - 14; [°C]	1.60+
307-322	High Temperature Delta T (MIC 1 - 16)	0 -> No, 2 - 5; [°C]	1.60+
323	Number of Standby Units	0 - 16	1.60+
371-386	Humidity Proportional Band (MIC 1 - 16)	10 - 30; [%RH]	1.60+
387-402	Temperature Proportional Band (MIC 1 - 16)	6.0 - 10.0; [0.1K]	1.60+
403	Shared Parameters	0 -> No, 1 -> Yes	1.60+
451-466	Humidity Setpoint (MIC 1 - 16)	19 -> No; 20 - 80; [%RH]	1.60+
467-482	Temperature Setpoint (MIC 1 - 16)	50 - 400; [1/10 °C]	1.60+

#### Status-Report-Acknowledge (Holding Register #1):

Read the document 'Hirolink for Modbus V X.XX - General Documentation' (X.XX is a placeholder for the current version of the Hirolink) for a description on how to use this data-point.

#### Single Alarm-Status (Holding Registers #3 - #18):

This item holds a value which represents the current alarm-state of single Microface.

It can be written to in order to perform either a 'Alarm Acknowledge'- or a 'Alarm Reset'-command on a single Microface:

##### 2 .. Alarm Reset:

This command will reset all alarms, warnings and messages currently present on a Microface. As a consequence alarms, warnings and messages that are inactive will disappear, will active alarms, warnings and messages will be reported again.

##### 4 .. Alarm Acknowledge:

This command will acknowledge all alarms, warnings and messages present on a Microface. As a consequence alarms, warnings and messages that were in an unacknowledged state will be acknowledged after the command.

When read, the value corresponds to the following states:

0 .. No alarm present

1 .. Message acknowledged (inactive)

3 .. Message acknowledged (active)

- 5 .. Message not acknowledged (inactive)
- 7 .. Message not acknowledged (active)
  
- 9 .. Warning acknowledged (inactive)
- 11.. Warning acknowledged (active)
- 13.. Warning not acknowledged (inactive)
- 15.. Warning not acknowledged (active)
  
- 17.. Alarm acknowledged (inactive)
- 19.. Alarm acknowledged (active)
- 21...Alarm not acknowledged (inactive)
- 23.. Alarm not acknowledged (active)
  
- 25.. Alarm and warning acknowledged (inactive)
- 27.. Alarm and warning acknowledged (active)
- 29.. Alarm and warning not acknowledged (inactive)
- 31.. Alarm and warning not acknowledged (active)

The terms 'acknowledged' and 'not acknowledged' define, if the reset-push-button on the Hiromatic has been pressed once in order to silence the buzzer or if the command 'Alarm Acknowledge' has been performed.

The terms 'active' and 'inactive' define, if the alarm, warning or message is still active, which means that after performing a alarm-reset (either by sending the appropriate command via the Modbus-network or by pressing the reset-push-button on the Hiromatic a second time) the alarm or warning will be reported again.

**NOTE:**

Although you can read the alarm-state of the whole system, it is not possible to issue a 'Alarm Acknowledge'- or 'Alarm Reset'-command for the whole system. Instead you have to issue these commands for each Microface separately.

### 3.4 Input-Register

Register #	Usage	Range; Unit	SW-Version
1	Event-ID	ID identifying the event	1.60+
2	Controller-ID	Controller-ID, where the event occurred	1.60+
3	Minute	Minute, when event occurred	1.60+
4	Hour	Hour, when event occurred	1.60+
5	Date	Date, when event occurred	1.60+
6	Event-Type	0 -> message, 1 -> warning, 2 -> alarm, 3 and 4 -> reset	1.60+
7	System Alarm	See explanation below	1.60+
8	System Status	See explanation below	1.60+
25-40	Status Dehumidification (MIC 1 - 16)	0 -> Off, 1 -> On	1.60+
41-56	Status Electrical Heater 2 (MIC 1 - 16)	0 -> Off, 1 -> On	1.60+
57-72	Status Electrical Heater 1 (MIC 1 - 16)	0 -> Off, 1 -> On	1.60+
73-88	Status Compressor 1 (MIC 1 - 16)	0 -> Off, 1 -> On	1.60+
89-104	Status Fan (MIC 1 - 16)	0 -> Off, 1 -> On	1.60+
105	Shared Humidity (average of all humidity-sensors) (MIC 1 - 16)	0 - 100; [%RH]	1.60+
121	Shared Temperature (average of all temperature-sensors) (MIC 1 - 16)	-300 - 1000; [1/10 °C]	1.60+
137-152	Single Status (per Unit) (MIC 1 - 16)	See explanation below	1.60+
153-168	Humidifier Current	0 - 4000; [1/100 A]	1.60+
201-216	Supply Air Temperature (MIC 1 - 16)	-300 - 1000; [1/10 °C]; see explanation below	1.60+
217-232	Humidity (MIC 1 - 16)	0-1000; [1/10 %RH]; see explanation below	1.60+
233-248	Temperature (MIC 1 - 16)	-300 - 1000; [1/10 °C]; see explanation below	1.60+
249-264	Actual Temperature Setpoint (MIC 1 - 16)	50 - 400; [1/10 °C]	1.60+
361-376	Analog Output Ramp 2 (MIC 1 - 16) (follows the setting of the 2 <sup>nd</sup> analog output)	0 - 100; [%]	1.60+

#### Status-Report-Block (Input Register #1 - #6):

Read the document 'Hirolink for Modbus V X.XX - General Documentation' (X.XX is a placeholder for the current version of the Hirolink) for a description on how to use these data-points.

#### System-Alarm (Input Register #7):

This item holds a value, which represents the current alarm-state of the whole system. This alarm-state is calculated from the single alarm-states of each Microface and holds the highest of those alarm-states. The single alarm-states can be read using the appropriate Holding Registers.

The values correspond to the following states:

- 0 .. No alarm present
- 1 .. Message acknowledged (inactive)
- 3 .. Message acknowledged (active)
- 5 .. Message not acknowledged (inactive)
- 7 .. Message not acknowledged (active)
  
- 9 .. Warning acknowledged (inactive)
- 11 .. Warning acknowledged (active)
- 13 .. Warning not acknowledged (inactive)

- 15 .. Warning not acknowledged (active)
- 17 .. Alarm acknowledged (inactive)
- 19 .. Alarm acknowledged (active)
- 21 .. Alarm not acknowledged (inactive)
- 23 .. Alarm not acknowledged (active)
- 25 .. Alarm and warning acknowledged (inactive)
- 27 .. Alarm and warning acknowledged (active)
- 29 .. Alarm and warning not acknowledged (inactive)
- 31 .. Alarm and warning not acknowledged (active)

The terms 'acknowledged' and 'not acknowledged' define, if the reset-push-button on the Hiromatic has been pressed once in order to silence the buzzer or if the command 'Alarm Acknowledge' has been performed.

The terms 'active' and 'inactive' define, if the alarm, warning or message is still active, which means that after performing a alarm-reset (either by sending the appropriate command via the Modbus-network or by pressing the reset-push-button on the Hiromatic a second time) the alarm or warning will be reported again.

### System-Status (Input Register #8) and Single Status (Input Registers #137 - #152):

This item holds a value, which represents the current system-state of the whole system and of the single Microfaces. The values correspond to the following states:

- 0 .. Alarm Off
- 1 .. Manual
- 2 .. Local Off
- 3 .. System Off
- 4 .. Standby Alarm
- 5 .. Standby
- 6 .. Sleep / Off
- 7 .. System On
- 8 .. Warning On
- 9 .. Alarm On
- 10 .. Sleep

### Supply Air Temperature (Input Register #201 - #216), Room Temperature (Input Registers #233 - #248):

In case of NO Humitemp-sensor being used to measure the current room temperature and humidity, the 'Supply Air Temperature'-input-registers will hold the current room temperature and the 'Room Temperature'- and 'Room Humidity'-input-registers will be invalid. With Hirolink for MODBUS V 2.88, starting from the E1G and EVG EPROM applications, in case of no Humitemp, the ambient temperature can be read both in Supply Air Temperature (Input Register #201 - #216), Room Temperature (Input Registers #233 - #248) registers.

### 3.5 Events

#### 3.5.1 Event-Registers

Starting from 'HL for Modbus - V 2.85', there is the possibility to read the current state of a single event through Input-Registers, each bit of these registers represents the state of one event:  
Examples:

Input-Register #5001:

State of Hiromatic-events from ID 0 to 15

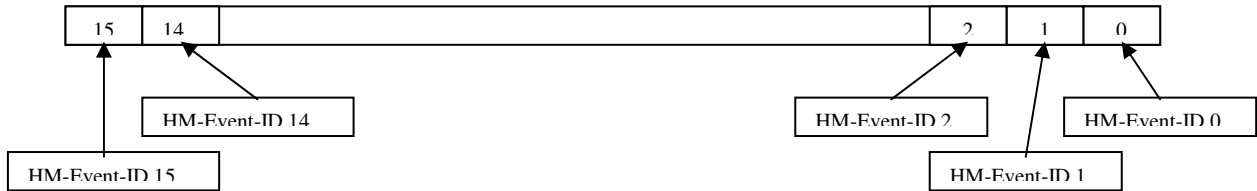

Input-Register #5009:

State of Microface-events from ID 0 to 15 from Microface with ID #1

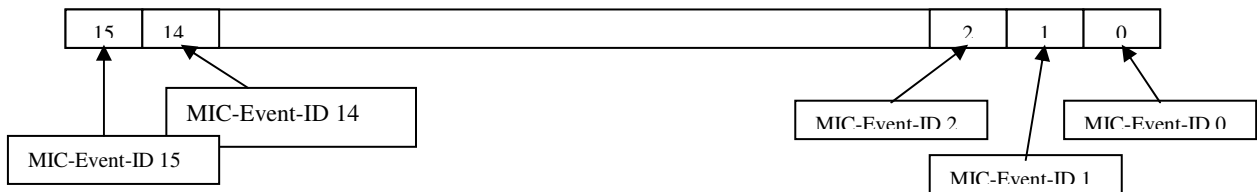

Register #	Usage
5001	Hiromatic-events #0-#15
5002	Hiromatic-events #16-#31
...	...
5008	Hiromatic-events #112-#127
5009	Microface #1-events #0-#15
5010	Microface #1-events #16-#31
...	...
5016	Microface #1-events #112-#127
5017	Microface #2-events #0-#15
5018	Microface #2-events #16-#31
...	...
5024	Microface #2-events #112-#127
...	...
5129	Microface #16-events #0-#15
5130	Microface #16-events #16-#31
...	...
5136	Microface #16-events #112-#127

The following chapter contains a list with all events available for this unit-type. Unused event-IDs will always be set to 0.

**NOTE:**

Events of type 'Message' and 'Reset' (see Event-list in the following chapter), will NOT cause a bit to be set in the Event-registers when they are reported by the Hiromatic. Furthermore, the events 'UNIT CONNECTED' (Event-ID 100) and 'UNIT NOT CONNECTED' (Event-ID 101), which are generated by the Hirolink itself, are also NOT available as single bits within the Event-registers.

These events are only available through the 'Status Report Block' (Input registers #1 - #6).

**For these controls boards and its applications the event registers are upgraded only if the 'Status-Report-Acknowledge' jumper is set; so Hirolink does the upgrades mandatory** (for more information see Modbus General Documentation Chapter '5.4 The Status-Report').

### 3.5.2 Event-List

**IMPORTANT:**

If you intend to read the current events through the ‘Status Report Block’ (Input-Registers #1 -#6), please read the document ‘Hirolink for Modbus V X.XX - General Documentation’ (X.XX is a placeholder for the current version of the Hirolink) for a detailed description on how to use these data-points.

In the following list you can see all Events and Event-IDs available for WXG-units:

Event-ID	Event-Description	Event-Type	SW-Version
0	General Alarm Reset	Acknowledge	1.60+
1	Compressor High Pressure	Alarm	1.60+
2	Compressor Low Pressure	Alarm	1.60+
3	High Chilled Water	Alarm	1.60+
4	Low Chilled Flow	Alarm	1.60+
5	Electrical Heater Overheated	Alarm	1.60+
6	Fan Failure	Warning	1.60+
7	Fan Failure	Alarm	1.60+
8	Clogged Filter	Warning	1.60+
9	Water Leakage	Warning	1.60+
10	Water Leakage	Alarm	1.60+
13	Humidifier Failure	Warning	1.60+
14	Humidifier High Current	Warning	1.60+
15	Humidifier Failure	Warning	1.60+
16	Humidifier Failure	Warning	1.60+
17	Humidifier Cylinder Worn	Warning	1.60+
18	High Supply Temperature Level 1	Warning	1.60+
19	Low Supply Temperature Level 1	Warning	1.60+
20	High Return Humidity Level 1	Warning	1.60+
21	Low Return Humidity Level 1	Warning	1.60+
22	High Supply Temperature Level 2	Warning	1.60+
23	Low Supply Temperature Level 2	Warning	1.60+
24	High Return Humidity Level 2	Warning	1.60+
25	Low Return Humidity Level 2	Warning	1.60+
26	Conditioner Working Hours Exceeded	Warning	1.60+
27	Compressor Working Hours Exceeded	Warning	1.60+
28	Humidifier Working Hours Exceeded	Warning	1.60+
29	Supply Temperature Sensor Failure	Warning	1.60+
30	Return Temperature and Humidity Sensor Failure	Warning	1.60+
31	Sensors Not Available	Alarm	1.60+
33	Water Sensor Presence Failure	Warning	1.60+
34	Network Failure	Warning	1.60+
36	Unit ON	Message	1.60+
37	Unit OFF	Message	1.60+
39	Standby Mode	Message	1.60+
40	Power ON Unit Login	Message	1.60+
41	Power OFF	Message	1.60+
42	Unit 1 Disconnected	Warning	1.60+
43	Unit 2 Disconnected	Warning	1.60+
44	Unit 3 Disconnected	Warning	1.60+
45	Unit 4 Disconnected	Warning	1.60+
46	Unit 5 Disconnected	Warning	1.60+
47	Unit 6 Disconnected	Warning	1.60+
48	Unit 7 Disconnected	Warning	1.60+
100	UNIT CONNECTED	Message	1.60+
101	UNIT NOT CONNECTED	Message	1.60+

## 4. Document-Changes

This appendix contains all changes that have been applied to this document up to the current version:

This is the first version of this document.

## Connectivity

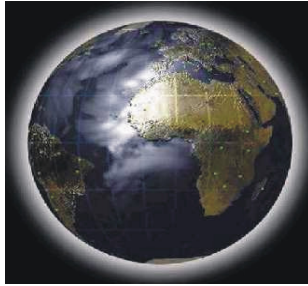

*The evolution*

# Hirolink for Modbus V 3.00

Items for AA Legacy - 'ICOM board' – Units V 1.60+

Service Manual

English



## CONTENTS

<b>1.</b>	<b>INTRODUCTION .....</b>	<b>3</b>
<b>2.</b>	<b>COMPATIBILITY-LIST .....</b>	<b>3</b>
	PREPARING THE ICOM BOARD.....	3
<b>3.</b>	<b>ITEMS FOR ICOM BOARD AAM 'ICOM BOARD' .....</b>	<b>6</b>
3.1	COILS .....	6
3.2	INPUT-STATUS .....	6
3.3	HOLDING REGISTER .....	7
3.4	INPUT-REGISTER.....	9
3.5	EVENTS .....	11
3.5.1	<i>Event-Registers.....</i>	<i>11</i>
3.5.2	<i>Event-List.....</i>	<i>12</i>
<b>A.</b>	<b>DOCUMENT-CHANGES.....</b>	<b>14</b>

## 1. Introduction

This document contains a description of all data-points that are available via the 'Hirolink for Modbus' from this type of air-conditioner.

### **IMPORTANT:**

It is vital to the correct integration of the Hirolink into a Modbus-network, that you have read and understood the topics described in the document 'Hirolink for Modbus V X.XX - General Documentation' (X.XX is a placeholder for the current version of the Hirolink). So, if you haven't read this document until now, read it first.

## 2. Compatibility-List

### ***Preparing the iCOM board***

- Note: there are 2 different types of **iCOM board** available:
  - **Medium board**and
  - **Large board**

The following steps will describe the actions to be done for both types.

To prepare the iCOM board for a connection to the Hirolink, carry out the following actions:

### **Step 1: Check the Hironet-settings (Medium and Large boards)**

In order to verify-modify the Hironet-ID-settings it is necessary to have at least one of these displays:

- 3-Digit display
- Cold Fire Displays
- Hiromatic E

connects to the iCOM board and find the "id" parameter.

These settings define the Identification-number and the baudrate and in some cases also the protocol and the communication-mode. Each of these settings is described in the following:

### ***Identification-number:***

The identification-number set on the iCOM board defines the Modbus-Slave-ID, which has to be used to request data from the iCOM board. As mentioned in the description of the protocol, this Slave-ID must be unique. Therefore it is very important that each iCOM board receives a different identification-number.

After setting the identification-number, note it together with the software-information described in step 1. It is good advice to also note the position of the iCOM board within the building.

### ***Baudrate:***

It is fixed to 19200Bd.

## Step 2: Modbus Network structure (iCOM Medium-Large connections)

### Medium board:

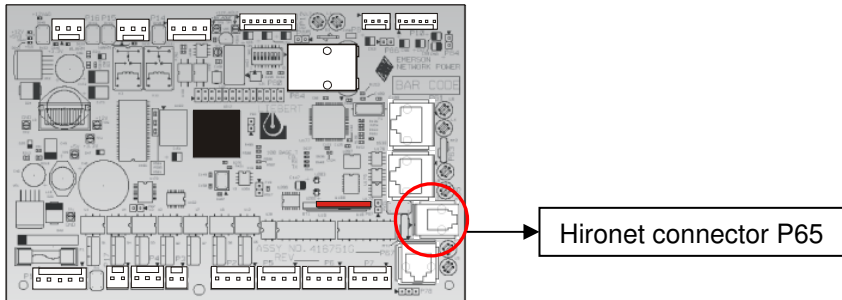

### Large board:

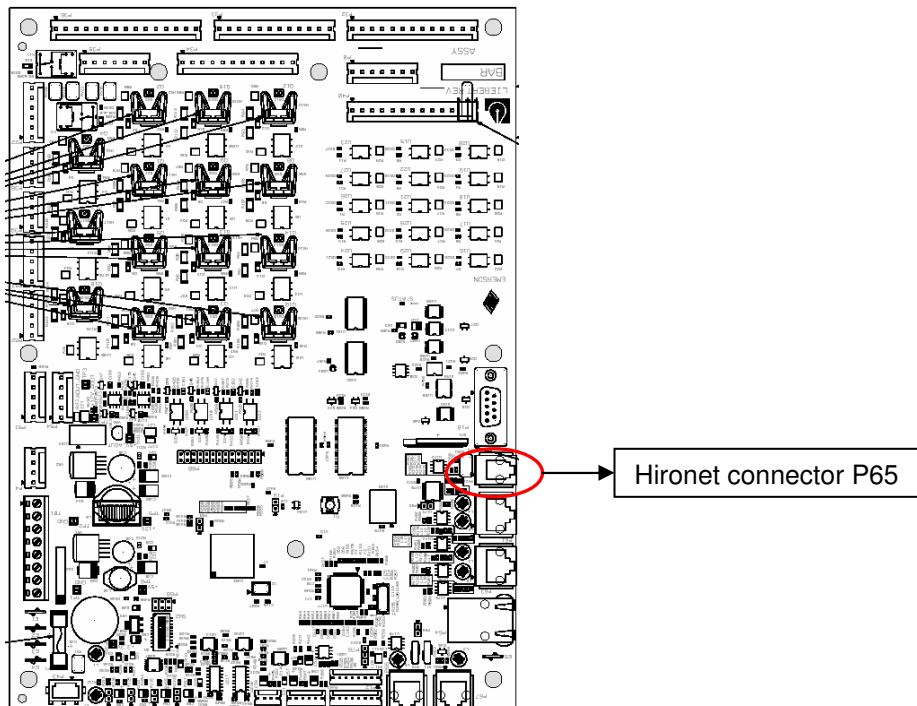

A **T-connector** for RJ9 type can be used when more iCOM board need to be connected together. The T-connector makes the connection task easy (T-connector Code 275655).

This network-type is easy to install and therefore commonly used. You have to use a 4-wire cable, where the connection is done in a 1-to-1 manner. This means that each pin on one interface-card has to be connected to the same pin on the next interface-card.

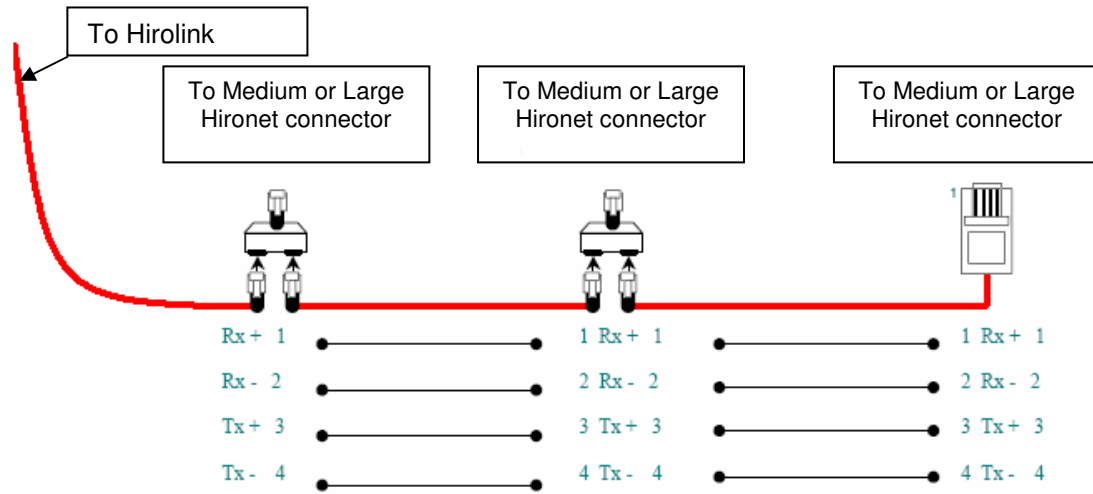

### **3. Items for iCOM board AAM ‘ICOM board’**

According to the Modbus-protocol-specifications the values and parameters provided by the ICOM board are represented in 4 groups:

- Coils: Used for changeable, digital values
- Inputs: Used for not changeable, digital values
- Holding Registers: Used for changeable, analog values
- Input Registers: Used for not changeable, analog values

Therefore the column ‘SW-Version’ contained in the following lists provides information about the availability of each item depending on the iCOM board-software-version. For example an entry like ‘1.60+’ means, that this item is available from ICOM boards with software-version 1.60 and higher.

**IMPORTANT:**

The available data-points shown in the following chapters are numbered starting from 1, according to the Modbus-Protocol-Specification. Still some BMS start numbering the data-points from 0.

So, in case that the BMS you are using starts numbering from 0, you have to decrease the listed numbers by 1.

#### **3.1 Coils**

Not used on this ICOM board-type.

#### **3.2 Input-Status**

Not used on this ICOM board-type.

**3.3 Holding Register**

Register #	Usage	Range; Unit	SW-Version
1	Status-Report-Acknowledge	See explanation below	1.60+
2	Alarm Status	See explanation below	1.60+
3	Unit System On/Off	0 -> Unit System Off; 1 -> Unit System On	1.60+
4	Sensor Priority Zone 1	0 = No, 1-100 [%]	1.60+
5	Sensor Priority Zone 2	0 = No, 1-100 [%]	1.60+
6	Sensor Priority Zone 3	0 = No, 1-100 [%]	1.60+
7	Fan Working Hours	0 - 32000; [h]	1.60+
8	Not Used	--	1.60+
9	Not Used	--	1.60+
10	Not Used	--	1.60+
11	Not Used	--	1.60+
12	Not Used	--	1.60+
13	Force damper and fan to 100%	0 = No, 1 = Yes	1.60+
14	Rotation Type (unit 1 only)	0 = No, 1 = Daily, 2 = Mon 3 = Tue, 4 = Wed, 5 = Thu 6 = Fri, 7 = Sat, 8 = Sun 9 = Monthly (Mon) 10 = Monthly (Tue) 11 = Monthly (Wed) 12 = Monthly (Thu) 13 = Monthly (Fri) 14 = Monthly (Sat) 15 = Monthly (Sun)	1.60+
15	Rotation Time (unit 1 only)	0 - 59; [min]	1.60+
16	Rotation Time (unit 1 only)	0 - 23; [h]	1.60+
17	Zone Temperature Control (If Teamwork 1 than unit 1 only)	0 = Lowest, 1 = Highest 2 = Average	1.60+
18	Force Rotation	0 = No, 1 = Yes	1.60+
19	Next Fan Off at (Unit 1 only) (-0.1 = 255 / -5.0 = 206)	-5.0 - 0.0 °C	1.60+
20	High Temperature Warning Level 2	0 -> No, 1 - 99; [°C]	1.60+
21	High Temperature Warning Level 1	0 -> No, 1 - 99; [°C]	1.60+
22	Number of Standby Units (Unit 1 only)	0 - 15	1.60+
23	Supply Temperature Integration Factor	4 -> No, 5 -15; [min]	1.60+
24	Zone Temperature Integral Factor	4 -> No, 5 -15; [min]	1.60+
25	Supply Temperature Proportional Band	5 - 20; [K]	1.60+
26	Zone Temperature Proportional Band	10 - 100; [1/10 K]	1.60+
27	Teamwork	0 -> No, 1 -> Yes	1.60+
28	Fanspeed Max	50 - 100; [%]	1.60+
29	Supply Air Temperature Setpoint	5 - 25; [°C]	1.60+
30	Return Humidity Setpoint	19 -> No; 20 - 80; [%RH]	1.60+
31	Zone Temperature Setpoint	50 - 400; [1/10 °C]	1.60+
32	Not Used	--	1.60+
33	Fanspeed Min.	30 - 50 [%]	1.60+
34	System Fanspeed Limit(Unit 1 only)	30 - 100 [%]	1.60+
35	Fan Cascade Enabled (Unit 1 only)	0 = No, 1 = Mode 1 2 = Mode 2	1.60+
36	Next Fan ON delay	0 = No, 1 - 25 (hours)	1.60+
37	Next Fan OFF delay	0 = No, 1 - 25 (hours)	1.60+

## Status-Report-Acknowledge (Holding Register #1):

Read the document 'Hirolink for Modbus V X.XX - General Documentation' (X.XX is a placeholder for the current version of the Hirolink) for a description on how to use this data-point.

## Alarm-Status (Holding Registers #2):

This item holds a value which represents the current alarm-state of single ICOM board.

It can be written to in order to perform either a 'Alarm Acknowledge'- or a 'Alarm Reset'- command on a single ICOM board:

### 2 .. Alarm Reset:

This command will reset all alarms, warnings and messages currently present on a ICOM board. As a consequence alarms, warnings and messages that are inactive will disappear, will active alarms, warnings and messages will be reported again.

### 4 .. Alarm Acknowledge:

This command will acknowledge all alarms, warnings and messages present on a ICOM board. As a consequence alarms, warnings and messages that were in an unacknowledged state will be acknowledged after the command.

When read, the value corresponds to the following states:

- 0 .. No alarm present
- 1 .. Message acknowledged (inactive)
- 3 .. Message acknowledged (active)
- 5 .. Message not acknowledged (inactive)
- 7 .. Message not acknowledged (active)
- 9 .. Warning acknowledged (inactive)
- 11.. Warning acknowledged (active)
- 13.. Warning not acknowledged (inactive)
- 15.. Warning not acknowledged (active)
- 17.. Alarm acknowledged (inactive)
- 19.. Alarm acknowledged (active)
- 21...Alarm not acknowledged (inactive)
- 23.. Alarm not acknowledged (active)
- 25.. Alarm and warning acknowledged (inactive)
- 27.. Alarm and warning acknowledged (active)
- 29.. Alarm and warning not acknowledged (inactive)
- 31.. Alarm and warning not acknowledged (active)

The terms 'acknowledged' and 'not acknowledged' define, if the reset-push-button on the **iCOM Cold fire display** has been pressed once or if the 'Alarm Acknowledge' command has been performed by BMS in order to silence the buzzer.

The terms 'active' and 'inactive' define, if the alarm, warning or message is still active, which means that after performing an alarm-reset (either by sending the appropriate command via the Modbus-network or by pressing the reset-push-button on the **iCOM Cold fire display** a second time) the alarm or warning will be reported again in case the alarm situation is still present.

**NOTE:**

Although you can read the alarm-state of the whole system (see 3.4 'Input-Register'), it is not possible to issue an 'Alarm Acknowledge'- or 'Alarm Reset'-command for the whole system. Instead you have to issue these commands for each ICOM board separately.

**3.4 Input-Register**

Register #	Usage	Range; Unit	SW-Version
1	Event-ID	ID identifying the event	1.60+
2	Controller-ID	Controller-ID, where the event occurred	1.60+
3	Minute	Minute, when event occurred	1.60+
4	Hour	Hour, when event occurred	1.60+
5	Date	Date, when event occurred	1.60+
6	Event-Type	0 -> message, 1 -> warning 2 -> alarm, 3 and 4 -> reset	1.60+
7	Alarm Status	See explanation below	1.60+
8	Unit Status	See explanation below	1.60+
9	Actual CW Valve Ramp	0 - 100; [%]	1.60+
10	Damper Status	0 = Closed, 1 0 open	1.60+
11	Not Used	--	1.60+
12	Not Used	--	1.60+
13	Not Used	--	1.60+
14	Status Fan	0 = Off, 1 = On	1.60+
15	Actual Retetrun Humidity	0-1000; [1/10 %RH];	1.60+
16	Actual calculated Unit Temperature	-300 - 1000; [1/10 °C]	1.60+
17	Actual Supply Temperature	-300 - 1000; [1/10 °C]	1.60+
18	Not Used	--	1.60+
19	Actual System Temperature (unit 1 only)	-300 - 1000; [1/10 °C]	1.60+
20	Actual Zone 3 Sensor Temperature	-300 - 1000; [1/10 °C]	1.60+
21	Actual Zone Temperature Setpoint	50 - 400; [1/10 °C]	1.60+
22	Fan and Damper Forced to 100%	0 = No, 1 = Yes	1.60+
23	Actual Zone 2 Sensor Temperature	-300 - 1000; [1/10 °C]	1.60+
24	Actual Zone 1 Sensor Temperature	-300 - 1000; [1/10 °C]	1.60+
25	Password Status Check	0 = Not Activated 1 = Activated	1.60+
26	Actual Fanspeed	0 - 100; [%]	1.60+



### Status-Report-Block (Input Register #1 - #6):

Read the document 'Hirolink for Modbus V X.XX - General Documentation' (X.XX is a placeholder for the current version of the Hirolink) for a description on how to use these data-points.

### Alarm Status (Input Register #7):

This item holds a value, which represents the current alarm-state of the whole system. This alarm-state is calculated from the single alarm-states of each ICOM board and holds the highest of those alarm-states. The single alarm-states can be read using the appropriate Holding Registers (see 3.3 'Holding Register').

The values correspond to the following states:

- 0 .. No alarm present
- 1 .. Message acknowledged (inactive)
- 3 .. Message acknowledged (active)
- 5 .. Message not acknowledged (inactive)
- 7 .. Message not acknowledged (active)
  
- 9 .. Warning acknowledged (inactive)
- 11 .. Warning acknowledged (active)
- 13 .. Warning not acknowledged (inactive)
- 15 .. Warning not acknowledged (active)
  
- 17 .. Alarm acknowledged (inactive)
- 19 .. Alarm acknowledged (active)
- 21 .. Alarm not acknowledged (inactive)
- 23 .. Alarm not acknowledged (active)
  
- 25 .. Alarm and warning acknowledged (inactive)
- 27 .. Alarm and warning acknowledged (active)
- 29 .. Alarm and warning not acknowledged (inactive)
- 31 .. Alarm and warning not acknowledged (active)

The terms 'acknowledged' and 'not acknowledged' define, if the reset-push-button on the iCOM Cold fire display or Hiromatic E has been pressed once in order to silence the buzzer or if the 'Alarm Acknowledge' command has been performed by BMS in order to silence the buzzer.

The terms 'active' and 'inactive' define, if the alarm, warning or message is still active, which means that after performing an alarm-reset (either by sending the appropriate command via the Modbus-network or by pressing the reset-push-button on the iCOM Cold fire display or Hiromatic E a second time) the alarm or warning will be reported again.

### Unit Status (Input Register #8):

This item holds a value, which represents the current system-state of the whole system and of the single ICOM boards. The values correspond to the following states:

- 0 .. Alarm Off
- 1 .. Manual
- 2 .. Local Off
- 3 .. System Off
- 4 .. Standby Alarm
- 5 .. Standby
- 6 .. Sleep / Off
- 7 .. System On
- 8 .. Warning On
- 9 .. Alarm On
- 10 .. Sleep

## Actual Calculated Zone Temperature (Input Registers #16),

It represents the calculated value of the zone temperature sensor according to the Zone Temperature Control setting (see Holding Register #17).

If any Zone sensor is used (see Input Register #20,23,24) it represents the temperature read by the Humitemp sensor mounted on board.

Note: in case of system the Humitemp value will be shown if only any sensor is available on the entire system

### 3.5 Events

#### 3.5.1 Event-Registers

Starting from 'Hirolink for Modbus - V 2.85', there is the possibility to read the current state of a single event through Input-Registers, where each bit of these registers represents the state of one event:

Examples:

Input-Register #5001:  
State of ICOM board-events from ID 0 to 15

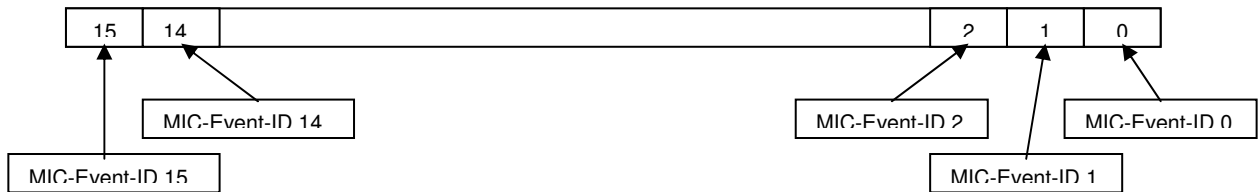

Register #	Usage
5001	ICOM board events #0-#15
5002	ICOM board events #16-#31
...	...
5008	ICOM board events #112-#127

The following chapter contains a list with all events available for this unit-type. Unused event-IDs will always be set to 0.

#### NOTE:

It events of type 'Message' and 'Reset' (see Event-list in the following chapter), will NOT cause a bit to be set in the Event-registers.

Furthermore, the events 'UNIT CONNECTED' (Event-ID 100) and 'UNIT NOT CONNECTED' (Event-ID 101), which are generated by the Hirolink itself, are also NOT available as single bits within the Event-registers.

These events are only available through the 'Status Report Block' (Input registers #1 - #6) described in chapter 3.4 'Input-Register'.

**For these controls boards and its applications the event registers are upgraded only if the 'Status-Report-Acknowledge' jumper is set; so Hirolink does the upgrades mandatorily** (for more information see Modbus General Documentation Chapter '5.4 The Status-Report').

### 3.5.2 Event-List

**IMPORTANT:**

If you intend to read the current events through the 'Status Report Block' (Input-Registers #1 - #6), please read the document 'Hirolink for Modbus V X.XX - General Documentation' (X.XX is a placeholder for the current version of the Hirolink) for a detailed description on how to use these data-points.

In the following list you can see all Events and Event-IDs available for AAL/S-units (Large or Small Display):

Event-ID	Event-Description	Event-Type	SW-Version
0	GENERAL ALARM	Reset	1.60+
1	COMPRESSOR 1 HIGH PRESSURE	Alarm	1.60+
2	COMPRESSOR 1 LOW PRESSURE	Alarm	1.60+
3	HIGH CHILLED WATER TEMPERATURE	Warning	1.60+
4	LOW CHILLED WATER FLOW	Warning	1.60+
5	ELECTRICAL HEATERS OVERHEATED	Warning	1.60+
6	FAN FAILURE	Warning	1.60+
7	FAN FAILURE	Alarm	1.60+
8	CLOGGED FILTERS	Warning	1.60+
9	WATER LEAKAGE DETECTED	Warning	1.60+
10	WATER LEAKAGE DETECTED	Alarm	1.60+
11	USER INPUT TRIGGERED	Warning	1.60+
12	USER INPUT TRIGGERED	Alarm	1.60+
13	EXTERNAL HUMIDIFIER FAILURE	Warning	1.60+
14	HUMIDIFIER HIGH CURRENT	Warning	1.60+
15	HUMIDIFIER FAILURE	Warning	1.60+
16	HUMIDIFIER FAILURE	Warning	1.60+
17	HUMIDIFIER CYLINDER WARNING	Warning	1.60+
18	HIGH TEMPERATURE LEVEL 1	Warning	1.60+
19	LOW ROOM TEMPERATURE	Warning	1.60+
20	HIGH ROOM HUMIDITY	Warning	1.60+
21	LOW ROOM HUMIDITY	Warning	1.60+
22	HIGH TEMPERATURE LEVEL 2	Warning	1.60+
23	LOW ROOM TEMPERATURE (EEAP)	Warning	1.60+
24	HIGH ROOM HUMIDITY (EEAP)	Warning	1.60+
25	LOW ROOM HUMIDITY (EEAP)	Warning	1.60+
26	CONDITIONER WORKING HOURS EXCEEDED	Warning	1.60+
27	COMPRESSOR 1 WORKING HOURS EXCEEDED	Warning	1.60+
28	HUMIDIFIER WORKING HOURS EXCEEDED	Warning	1.60+
29	SUPPLY TEMPERATURE SENSOR FAILURE	Warning	1.60+
30	HUMITEMP SENSOR FAILURE	Warning	1.60+
31	HUMITEMP SENSOR FAILURE	Alarm	1.60+
32	EEAP SENSOR FAILURE	Warning	1.60+
33	WATER PRESENCE SENSOR FAILURE	Warning	1.60+
34	NETWORK FAILURE	Warning	1.60+
35	OUT OF MEMORY	Warning	1.60+
36	UNIT ON	Message	1.60+
37	UNIT OFF	Message	1.60+
38	SLEEP MODE	Message	1.60+
39	STANDBY MODE	Message	1.60+
40	POWER ON	Message	1.60+
41	POWER OFF	Message	1.60+
42	UNIT 1 DISCONNECTED	Alarm	1.60+

43	UNIT 2 DISCONNECTED	Alarm	1.60+
44	UNIT 3 DISCONNECTED	Alarm	1.60+
45	UNIT 4 DISCONNECTED	Alarm	1.60+
46	UNIT 5 DISCONNECTED	Alarm	1.60+
47	UNIT 6 DISCONNECTED	Alarm	1.60+
48	UNIT 7 DISCONNECTED	Alarm	1.60+
49	UNIT 8 DISCONNECTED	Alarm	1.60+
50	UNIT 9 DISCONNECTED	Alarm	1.60+
51	UNIT 10 DISCONNECTED	Alarm	1.60+
52	UNIT 11 DISCONNECTED	Alarm	1.60+
53	UNIT 12 DISCONNECTED	Alarm	1.60+
54	UNIT 13 DISCONNECTED	Alarm	1.60+
55	UNIT 14 DISCONNECTED	Alarm	1.60+
56	UNIT 15 DISCONNECTED	Alarm	1.60+
57	UNIT 16 DISCONNECTED	Alarm	1.60+
58	COMPRESSOR 2 HIGH PRESSURE	Alarm	1.60+
59	COMPRESSOR 2 LOW PRESSURE	Alarm	1.60+
60	COMPRESSOR 2 WORKING HOURS EXCEEDED	Warning	1.60+
61	ZONE 1 TEMPERATURE SENSOR FAILURE	Warning	1.60+
62	ZONE 2 TEMPERATURE SENSOR FAILURE	Warning	1.60+
63	FREECOOLING STOPPED FOR 1 HOUR	Message	1.60+
64	ON-OFF BY HIROMATIC NOT ENABLED	Warning	1.60+
65	SMOKE ALARM	Warning	1.60+
66	NO POWER (USER INPUT)	Message	1.60+
67	POWER ON (USER INPUT)	Message	1.60+
68	USER INPUT 2 TRIGGERED	Warning	1.60+
69	USER INPUT 2 TRIGGERED	Alarm	1.60+
70	NO CONNECTION TO UNIT 1	Warning	1.60+
71	COMPRESSOR 1 MOTOR PROTECTION	Alarm	1.60+
72	COMPRESSOR 2 MOTOR PROTECTION	Alarm	1.60+
73	FIRE ALARM	Alarm	1.60+
74	OUT OF MEMORY	Warning	1.60+
75	CONDENSER 1 FAN FAILURE	Warning	1.60+
76	CONDENSER 2 FAN FAILURE	Warning	1.60+
77	HIROBUS ERROR	Warning	1.60+
78	SUBGROUP-ID NOT UNIQUE	Warning	1.60+
79	SUBGROUP-UNIT 1 NOT CONNECTED	Warning	1.60+
80	SUBGROUP-UNIT 2 NOT CONNECTED	Warning	1.60+
81	SHARE SENSOR FAILURE	Warning	1.60+
82	SHARE SENSOR FAILURE	Alarm	1.60+
83	SHARE OUTDOOR TEMP. SENSOR	Warning	1.60+
84	SHARE GLYCOL TEMP. SENSOR	Warning	1.60+
85	UNIT SYNCHRONISATION (=Short Reset)	Message	1.60+
86	HUMIDIFIER HIGH TEMPERATURE	Alarm	1.60+
87	ZONE 3 TEMPERATURE SENSOR FAILURE	Warning	1.60+
88	HEATER 1/2 WORKING HOURS EXCEEDED	Alarm	1.60+
89	FREECOOLING WORKING HOURS EXCEEDED	Alarm	1.60+
90	AIRFLOW DEVICE NOT READY, PLEASE CHECK	Alarm	1.60+
100	UNIT CONNECTED	Message	1.60+
101	UNIT NOT CONNECTED	Message	1.60+

## ***A.Document-Changes***

This appendix contains all changes that have been applied to this document up to the current version:

This is the first version of this document.