

BMS - Modbus

The Modbus protocol provides the internal standard that the controllers use for parsing messages. During communications on a Modbus network, the protocol determines how each controller will know its device address, recognize a message addressed to it, determine the kind of action to be taken, and extract any data or other information contained in the message. If a reply is required, the controller will construct the reply message and send it using Modbus protocol.

Variable Database

A specific communication database is featured that includes all the more important program variables, from the values read by the probes to the parameters set on the screens. The following table describes the database, divided into digital, integer and analogue variables, indicating for each its description, address and type, that is read only (R) or modifiable from the supervisor (R/W). Also, the equivalent address and type of parameters for Modbus protocol shown in the table.

- Modbus uses RTU mode.
- Communication parameters: 8 data bit
2 stop bit
no parity
speed from 1200 to 19200 baud rate
- Coding System: 8-bit binary, hexadecimal 0–9, A–F
Two hexadecimal characters contained in each 8-bit field of the message
- Error Check Field: Cyclical Redundancy Check (CRC)
- Carel protocol: Analogue (max 127), Integer (max 127) , Digital (max 199)
- Modbus protocol: Coils (Carel Digital), Register (Carel Analog+Integer)

Slave database

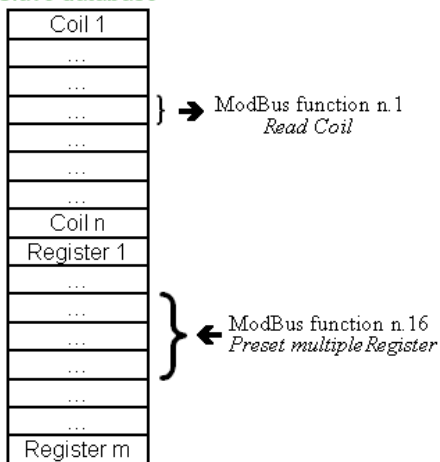

Protocol fundamentals:

ModBus protocol is based on *Function*

Examples:

- Function 01: *Read Coil Status* (Reads 1 Coil)
- Function 03: *Read Holding Registers* (Reads 1 Register)
- Function 05: *Force Single Coil* (Writes 1 Coil)
- Function 06: *Preset Single Register* (Writes 1 Register)
- Function 15: *Force Multiple Coils* (Writes a group of Coils)
- Function 16: *Preset Multiple Registers* (Writes a group of Registers)



BMS - Modbus

Modbus Message Framing

START	ADDRESS	FUNCTION	DATA	CRC CHECK	END
	8 BITS	8 BITS	n x 8 BITS	16 BITS	

RTU Message Frame

How the Address Field is Handled

The address field of a message frame contains eight bits (RTU). Valid slave device addresses are in the range of 0 – 247 decimal. The individual slave devices are assigned addresses in the range of 1 – 247. A master addresses a slave by placing the slave address in the address field of the message. When the slave sends its response, it places its own address in this address field of the response to let the master know which slave is responding. Address 0 is used for the broadcast address, which all slave devices recognize. When Modbus protocol is used on higher level networks, broadcasts may not be allowed or may be replaced by other methods.

How the Function Field is Handled

The function code field of a message frame contains eight bits (RTU). Valid codes are in the range of 1 – 255 decimal. Of these, some codes are reserved for future use. When a message is sent from a master to a slave device the function code field tells the slave what kind of action to perform. Examples are to read the ON/OFF states of a group of discrete coils or inputs; to read the data contents of a group of registers; to read the diagnostic status of the slave; to write to designated coils or registers; or to allow loading, recording, or verifying the program within the slave.

When the slave responds to the master, it uses the function code field to indicate either a normal (error-free) response or that some kind of error occurred (called an exception response). For a normal response, the slave simply echoes the original function code. For an exception response, the slave returns a code that is equivalent to the original function code with its most-significant bit set to a logic 1.

For example, a message from master to slave to read a group of holding registers would have the following function code:

0000 0011 (Hexadecimal 03)

If the slave device takes the requested action without error, it returns the same code in its response. If an exception occurs, it returns:

1000 0011 (Hexadecimal 83)

In addition to its modification of the function code for an exception response, the slave places a unique code into the data field of the response message. This tells the master what kind of error occurred, or the reason for the exception.

The master device's application program has the responsibility of handling exception responses. Typical processes are to post subsequent retries of the message, to try diagnostic messages to the slave, and to notify operators.

Contents of the Data Field

The data field is constructed using sets of two hexadecimal digits, in the range of 00 to FF hexadecimal. These can be made from one RTU character, according to the network's serial transmission mode. The data field of messages sent from a master to slave devices contains additional information which the slave must use to take the action defined by the function code. This can include items like discrete and register addresses, the quantity of items to be handled, and the count of actual data bytes in the field.

For example, if the master requests a slave to read a group of holding registers (function code 03), the data field specifies the starting register and how many registers are to be read. If the master writes to a group of registers in the slave (function code 10 hexadecimal), the data field specifies the starting register, how many registers to write, the count of data bytes to follow in the data field, and the data to be written into the registers.

If no error occurs, the data field of a response from a slave to a master contains the data requested. If an error occurs, the field contains an exception code that the master application can use to determine the next action to be taken. The data field can be nonexistent (of zero length) in certain kinds of messages. For example, in a request from a master device for a slave to respond with its communications event log (function code 0B hexadecimal), the slave does not require any additional information. The function code alone specifies the action.

BMS - Modbus

Modbus Message Framing (Continued)

Contents of the Error Checking Field

The error checking field contents depend upon the method that is being used.

When RTU mode is used for character framing, the error checking field contains a 16-bit value implemented as two 8-bit bytes. The error check value is the result of a Cyclical Redundancy Check calculation performed on the message contents. The CRC field is appended to the message as the last field in the message. When this is done, the low-order byte of the field is appended first, followed by the high-order byte. The CRC high-order byte is the last byte to be sent in the message.

Error Checking Methods

CRC Checking

In RTU mode, messages include an error-checking field that is based on a Cyclical Redundancy Check (CRC) method. The CRC field checks the contents of the entire message. It is applied regardless of any parity check method used for the individual characters of the message.

The CRC field is two bytes, containing a 16-bit binary value. The CRC value is calculated by the transmitting device, which appends the CRC to the message. The receiving device recalculates a CRC during receipt of the message, and compares the calculated value to the actual value it received in the CRC field. If the two values are not equal, an error results.

The CRC is started by first preloading a 16-bit register to all 1's. Then a process begins of applying successive 8-bit bytes of the message to the current contents of the register. Only the eight bits of data in each character are used for generating the CRC. Start and stop bits, and the parity bit, do not apply to the CRC.

During generation of the CRC, each 8-bit character is exclusive ORed with the register contents. Then the result is shifted in the direction of the least significant bit (LSB), with a zero filled into the most significant bit (MSB) position. The LSB is extracted and examined. If the LSB was a 1, the register is then exclusive ORed with a preset, fixed value. If the LSB was a 0, no exclusive OR takes place.

This process is repeated until eight shifts have been performed. After the last (eighth) shift, the next 8-bit byte is exclusive ORed with the register's current value, and the process repeats for eight more shifts as described above. The final contents of the register, after all the bytes of the message have been applied, is the CRC value.

When the CRC is appended to the message, the low-order byte is appended first, followed by the high-order byte. In ladder logic, the CKSM function calculates a CRC from the message contents.

CRC Generation Function

```
unsigned short CRC16(puchMsg, usDataLen)
```

```
unsigned char *puchMsg ; /* message to calculate CRC upon */  
unsigned short usDataLen ; /* quantity of bytes in message */
```

```
{  
    unsigned char uchCRCHi = 0xFF ; /* high byte of CRC initialized */  
    unsigned char uchCRCLo = 0xFF ; /* low byte of CRC initialized */  
    unsigned uIndex ; /* will index into CRC lookup table */  
    while (usDataLen—) /* pass through message buffer */  
    {  
        uIndex = uchCRCHi ^ *puchMsgg++ ; /* calculate the CRC */  
        uchCRCHi = uchCRCLo ^ auchCRCHi[uIndex] ;  
        uchCRCLo = auchCRCLo[uIndex] ;  
    }  
    return (uchCRCHi << 8 | uchCRCLo) ;  
}
```

BMS - Modbus

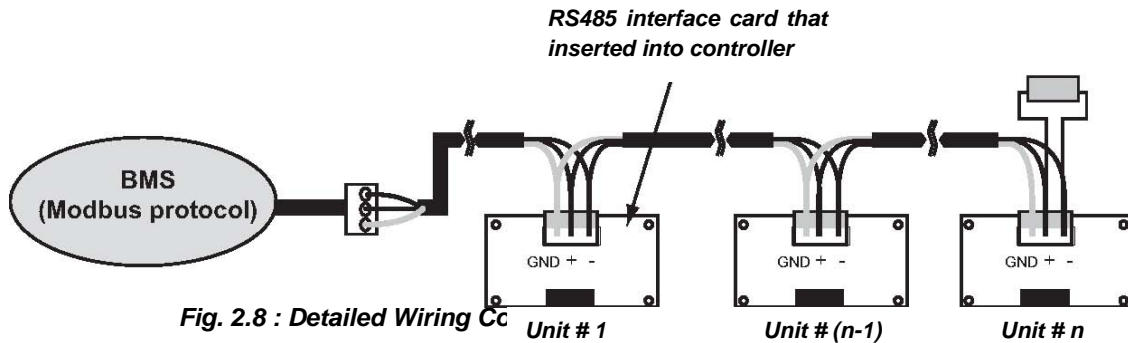

Hardware Setup

The wiring connection for the BMS with Modbus protocol is shown in Figure 2.8. The local connection between controller board and a supervisory PC requires the insertion of the RS485 additional card into the “serial card” port. Connection between controller boards in a network is carried out using an AWG20/22 shielded cable, twisted pair plus shield. The boards are connected in parallel. Maximum cable length that linkage in one network is 1000 meters. Pay ATTENTION to the network polarity: Rx/Tx+ on one board must be connected to Rx/Tx+ on the other boards; the same is true for Rx/Tx- and GND. Resistor 120 ohm shall be installed at last RS485 serial card in the network at terminal + and -.

Software Setup

There are a few parameters need to be set at software Level 2 - BMS Setup. The parameters are as below:

- i. BMS Enable - set to Yes
- ii. Protocol Type - set to Modbus
- iii. Baud Rate - set according to the user's system baud rate (1200 / 2400 / 4800 / 9600 / 19200)
- iv. Identity - set accordingly



BMS – VARIABLE LIST

A. Digital Variable

CITEC	MODBUS				BACnet		Remark
Address	Description	Type	Address	Type	Obj. Inst.	Obj Name	
1	BMS on off	R/W	1	Coil	1	D001	0=off / 1=on
2	Compressor 1 status	R	2	Coil	2	D002	0=off / 1=on
3	Compressor 2 status	R	3	Coil	3	D003	0=off / 1=on
4	Cooling on	R	4	Coil	4	D004	0=off / 1=on
5	Dehumidify on	R	5	Coil	5	D005	0=off / 1=on
7	Critical alarm	R	7	Coil	7	D007	0=no alarm / 1=alarm
8	Heating on	R	8	Coil	8	D008	0=off / 1=on
9	Heater 1 status	R	9	Coil	9	D009	0=off / 1=on
10	Heater 2 status	R	10	Coil	10	D010	0=off / 1=on
11	Humidify on	R	11	Coil	11	D011	0=off / 1=on
12	Alarm high current	R	12	Coil	12	D012	0=no alarm / 1=alarm
13	Fan on / Unit on	R	13	Coil	13	D013	0=off / 1=on
14	Alarm air flow fail	R	14	Coil	14	D014	0=no alarm / 1=alarm
15	Alarm filter block	R	15	Coil	15	D015	0=no alarm / 1=alarm
16	Alarm high humidity	R	16	Coil	16	D016	0=no alarm / 1=alarm
17	Alarm high temperature	R	17	Coil	17	D017	0=no alarm / 1=alarm
18	Alarm comp. 1 high pressure	R	18	Coil	18	D018	0=no alarm / 1=alarm
19	Alarm comp. 2 high pressure	R	19	Coil	19	D019	0=no alarm / 1=alarm
20	Alarm Klixon tripped	R	20	Coil	20	D020	0=no alarm / 1=alarm
21	Alarm low humidity	R	21	Coil	21	D021	0=no alarm / 1=alarm
22	Alarm low temperature	R	22	Coil	22	D022	0=no alarm / 1=alarm
23	Alarm comp. 1 low pressure	R	23	Coil	23	D023	0=no alarm / 1=alarm
24	Alarm comp. 2 low pressure	R	24	Coil	24	D024	0=no alarm / 1=alarm
25	Alarm Unit Health Check	R	25	Coil	25	D025	0=no alarm / 1=alarm
26	Alarm LAN disconnected	R	26	Coil	26	D026	0=no alarm / 1=alarm
27	Alarm unit run expired	R	27	Coil	27	D027	0=no alarm / 1=alarm
28	Alarm water on floor	R	28	Coil	28	D028	0=no alarm / 1=alarm
29	Alarm drip tray full	R	29	Coil	29	D029	0=no alarm / 1=alarm
30	Alarm high conductivity	R	30	Coil	30	D030	0=no alarm / 1=alarm
31	Alarm low production	R	31	Coil	31	D031	0=no alarm / 1=alarm
32	Drain alarm	R	32	Coil	32	D032	0=no alarm / 1=alarm
33	Alarm cylinder full	R	33	Coil	33	D033	0=no alarm / 1=alarm
34	Warning pre-exhaustion cylinder	R	34	Coil	34	D034	0=no alarm / 1=alarm
35	Warning foam presence	R	35	Coil	35	D035	0=no alarm / 1=alarm
36	Warning cylinder exhaustion	R	36	Coil	36	D036	0=no alarm / 1=alarm
37	Warning high conductivity	R	37	Coil	37	D037	0=no alarm / 1=alarm
38	Auxilliary alarm 1	R	38	Coil	38	D038	0=no alarm / 1=alarm
39	Auxilliary alarm 2	R	39	Coil	39	D039	0=no alarm / 1=alarm
40	Auxilliary alarm 3	R	40	Coil	40	D040	0=no alarm / 1=alarm
41	Alarm low current	R	41	Coil	41	D041	0=no alarm / 1=alarm
42	Unit 1 present in LAN	R	42	Coil	42	D042	0=absent / 1=present
43	Unit 2 present in LAN	R	43	Coil	43	D043	0=absent / 1=present
44	Unit 3 present in LAN	R	44	Coil	44	D044	0=absent / 1=present
45	Unit 4 present in LAN	R	45	Coil	45	D045	0=absent / 1=present
46	Unit 5 present in LAN	R	46	Coil	46	D046	0=absent / 1=present
47	Unit 6 present in LAN	R	47	Coil	47	D047	0=absent / 1=present
48	Unit 7 present in LAN	R	48	Coil	48	D048	0=absent / 1=present
49	Unit 8 present in LAN	R	49	Coil	49	D049	0=absent / 1=present
50	Alarm water in high temperature	R	50	Coil	50	D050	0=no alarm / 1=alarm
51	Alarm lack water	R	51	Coil	51	D051	0=no alarm / 1=alarm
52	Reset alarm	R/W	52	Coil	52	D052	0=no / 1=yes
53	Reset sirence	R/W	53	Coil	53	D053	0=no / 1=yes



BMS – VARIABLE LIST

CITEC		MODBUS			BACnet		Remark
Address	Description	Type	Address	Type	Obj. Inst.	Obj. Name	
63	Enable BMS on off	R/W	63	Coil	63	D063	0=no / 1=yes
73	Cylinder maintenance mandatory	R	73	Coil	73	D073	0=no / 1=yes
74	Cylinder maintenance recommended	R	74	Coil	74	D074	0=no / 1=yes
75	Previous alarm event (webgate)	R/W	75	Coil	75	D075	0=no / 1=yes
76	Next alarm event (webgate)	R/W	76	Coil	76	D076	0=no / 1=yes
77	Last alarm event (webgate)	R/W	77	Coil	77	D077	0=no / 1=yes
78	Alarm high discharge pressure 1	R	78	Coil	78	D078	0=no alarm / 1=alarm
79	Alarm high discharge pressure 2	R	79	Coil	79	D079	0=no alarm / 1=alarm
80	Warning high discharge pressure 1	R	80	Coil	80	D080	0=no alarm / 1=alarm
81	Warning high discharge pressure 2	R	81	Coil	81	D081	0=no alarm / 1=alarm
82	Alarm return air temperature sensor failed	R	82	Coil	82	D082	0=no alarm / 1=alarm
83	Alarm return air humidity sensor failed	R	83	Coil	83	D083	0=no alarm / 1=alarm
85	Alarm pressure probe 1 failed	R	85	Coil	85	D085	0=no alarm / 1=alarm
86	Alarm pressure probe 2 failed	R	86	Coil	86	D086	0=no alarm / 1=alarm
88	Unit off alarm	R	88	Coil	88	D088	0=no alarm / 1=alarm
90	Clock board error	R	90	Coil	90	D090	0=no alarm / 1=alarm
91	Supervisory system online status (Citec)	R	91	Coil	91	D091	0=offline / 1=online
92	Alarm anti freeze 1 tripped	R	92	Coil	92	D092	0=no alarm / 1=alarm
93	Alarm anti freeze 2 tripped	R	93	Coil	93	D093	0=no alarm / 1=alarm
94	Water in sensor failed	R	94	Coil	94	D094	0=no alarm / 1=alarm
95	Water out sensor failed	R	95	Coil	95	D095	0=no alarm / 1=alarm
96	Anti freeze 1 sensor failed	R	96	Coil	96	D096	0=no alarm / 1=alarm
97	Anti freeze 2 sensor failed	R	97	Coil	97	D097	0=no alarm / 1=alarm
98	Return air humidity sensor out of range	R	98	Coil	98	D098	0=no alarm / 1=alarm
99	Eeprom Error (EEV D1)	R	99	Coil	99	D099	0=no alarm / 1=alarm
100	Eeprom Error (EEV D2)	R	100	Coil	100	D100	0=no alarm / 1=alarm
101	Eeprom Error (EEV D3)	R	101	Coil	101	D101	0=no alarm / 1=alarm
105	MOP Time Out (EEV D1)	R	105	Coil	105	D105	0=no alarm / 1=alarm
106	MOP Time Out (EEV D2)	R	106	Coil	106	D106	0=no alarm / 1=alarm
107	MOP Time Out (EEV D3)	R	107	Coil	107	D107	0=no alarm / 1=alarm
108	LOP Time Out (EEV D1)	R	108	Coil	108	D108	0=no alarm / 1=alarm
109	LOP Time Out (EEV D2)	R	109	Coil	109	D109	0=no alarm / 1=alarm
110	LOP Time Out (EEV D3)	R	110	Coil	110	D110	0=no alarm / 1=alarm
111	Low Super Heat (EEV D1)	R	111	Coil	111	D111	0=no alarm / 1=alarm
112	Low Super Heat (EEV D2)	R	112	Coil	112	D112	0=no alarm / 1=alarm
113	Low Super Heat (EEV D3)	R	113	Coil	113	D113	0=no alarm / 1=alarm
114	High Super Heat (EEV D1)	R	114	Coil	114	D114	0=no alarm / 1=alarm
115	High Super Heat (EEV D2)	R	115	Coil	115	D115	0=no alarm / 1=alarm
116	High Super Heat (EEV D3)	R	116	Coil	116	D116	0=no alarm / 1=alarm
117	EEV Not Closed During Power Off (D1)	R	117	Coil	117	D117	0=no alarm / 1=alarm
118	EEV Not Closed During Power Off (D2)	R	118	Coil	118	D118	0=no alarm / 1=alarm
119	EEV Not Closed During Power Off (D3)	R	119	Coil	119	D119	0=no alarm / 1=alarm
120	Probe S1 (evap. pressure) Error (EEV D1)	R	120	Coil	120	D120	0=no alarm / 1=alarm
121	Probe S1 (evap. pressure) Error (EEV D2)	R	121	Coil	121	D121	0=no alarm / 1=alarm
122	Probe S1 (evap. pressure) Error (EEV D3)	R	122	Coil	122	D122	0=no alarm / 1=alarm
123	Probe S3 (suction temp.) Error (EEV D1)	R	123	Coil	123	D123	0=no alarm / 1=alarm
124	Probe S3 (suction temp.) Error (EEV D2)	R	124	Coil	124	D124	0=no alarm / 1=alarm
125	Probe S3 (suction temp.) Error (EEV D3)	R	125	Coil	125	D125	0=no alarm / 1=alarm
126	LAN Disconnected (EEV D1)	R	126	Coil	126	D126	0=no alarm / 1=alarm
127	LAN Disconnected (EEV D2)	R	127	Coil	127	D127	0=no alarm / 1=alarm
128	LAN Disconnected (EEV D3)	R	128	Coil	128	D128	0=no alarm / 1=alarm
129	Comp.3 HP Tripped	R	129	Coil	129	D129	0=no alarm / 1=alarm
130	Comp.3 LP Tripped	R	130	Coil	130	D130	0=no alarm / 1=alarm



BMS – VARIABLE LIST

CITEC		MODBUS			BACnet		Remark
Address	Description	Type	Address	Type	Obj_Inst.	Obj_Name	
131	Alarm Pressure Probe 3 Failed	R	131	Coil	131	D131	0=no alarm / 1=alarm
132	Alarm High Discharge Pressure 3	R	132	Coil	132	D132	0=no alarm / 1=alarm
133	Warning High Discharge Pressure 3	R	133	Coil	133	D133	0=no alarm / 1=alarm
134	Compressor 3 status	R	134	Coil	134	D134	0=off / 1=on



BMS – VARIABLE LIST

B. INTEGER VARIABLE

CITEC		MODBUS			BACnet		Remark
Address	Description	Type	Address	Type	Obj. Inst.	Obj. Name	
1	Day	R	129	Register	1001	I001	
2	Day week	R	130	Register	1002	I002	
3	Hour	R	131	Register	1003	I003	
4	Last history alarm event read	R	132	Register	1004	I004	
5	History alarm event	R	133	Register	1005	I005	refer Note Integer Var.
6	History day	R	134	Register	1006	I006	
7	History hour	R	135	Register	1007	I007	
8	History minute	R	136	Register	1008	I008	
9	History month	R	137	Register	1009	I009	
10	History year	R	138	Register	1010	I010	
11	Minute	R	139	Register	1011	I011	
12	Month	R	140	Register	1012	I012	
13	Unit address in LAN	R	141	Register	1013	I013	
14	Year	R	142	Register	1014	I014	
15	Unit status	R	143	Register	1015	I015	refer Note Integer Var.
17	Conductivity (uS/cm)	R	145	Register	1017	I017	
23	Rotation day (time zone rotation)	R/W	151	Register	1023	I023	
24	Delay time off fan	R/W	152	Register	1024	I024	
25	Delay time on fan	R/W	153	Register	1025	I025	
26	Derivative time	R/W	154	Register	1026	I026	
27	Function delay time	R/W	155	Register	1027	I027	
30	Rotation time hour change (time zone)	R/W	158	Register	1030	I030	
31	Flushing interval time (hours)	R/W	159	Register	1031	I031	
32	Inactivity drain interval time (days)	R/W	160	Register	1032	I032	
34	Integral time	R/W	162	Register	1034	I034	
35	Low pressure run delay time	R/W	163	Register	1035	I035	
36	Low pressure start delay time	R/W	164	Register	1036	I036	
42	Rotation time minute change (time zone)	R/W	170	Register	1042	I042	
43	Enable schedule on/off	R/W	171	Register	1043	I043	
44	Rotation type	R/W	172	Register	1044	I044	refer Note Integer Var.
45	Monday off hour (A) (Sch. On Off)	R/W	173	Register	1045	I045	
46	Monday off minute (A) (Sch. On Off)	R/W	174	Register	1046	I046	
47	Tuesday off hour (A) (Sch. On Off)	R/W	175	Register	1047	I047	
48	Tuesday off minute (A) (Sch. On Off)	R/W	176	Register	1048	I048	
49	Wednesday off hour (A) (Sch. On Off)	R/W	177	Register	1049	I049	
50	Wednesday off minute (A) (Sch. On Off)	R/W	178	Register	1050	I050	
51	Thursday off hour (A) (Sch. On Off)	R/W	179	Register	1051	I051	
52	Thursday off minute (A) (Sch. On Off)	R/W	180	Register	1052	I052	
53	Friday off hour (A) (Sch. On Off)	R/W	181	Register	1053	I053	
54	Friday off minute (A) (Sch. On Off)	R/W	182	Register	1054	I054	
55	Saturday off hour (A) (Sch. On Off)	R/W	183	Register	1055	I055	
56	Saturday off minute (A) (Sch. On Off)	R/W	184	Register	1056	I056	
57	Sunday off hour (A) (Sch. On Off)	R/W	185	Register	1057	I057	
58	Sunday off minute (A) (Sch. On Off)	R/W	186	Register	1058	I058	
59	Monday on hour (A) (Sch. On Off)	R/W	187	Register	1059	I059	
60	Monday on minute (A) (Sch. On Off)	R/W	188	Register	1060	I060	
61	Tuesday on hour (A) (Sch. On Off)	R/W	189	Register	1061	I061	
62	Tuesday on minute (A) (Sch. On Off)	R/W	190	Register	1062	I062	
63	Wednesday on hour (A) (Sch. On Off)	R/W	191	Register	1063	I063	
64	Wednesday on minute (A) (Sch. On Off)	R/W	192	Register	1064	I064	
65	Thursday on hour (A) (Sch. On Off)	R/W	193	Register	1065	I065	



BMS – VARIABLE LIST

CITEC		MODBUS			BACnet		Remark
Address	Description	Type	Address	Type	Obj_Inst.	Obj_Name	
66	Thursday on minute (A) (Sch. On Off)	R/W	194	Register	1066	I066	
67	Friday on hour (A) (Sch. On Off)	R/W	195	Register	1067	I067	
68	Friday on minute (A) (Sch. On Off)	R/W	196	Register	1068	I068	
69	Saturday on hour (A) (Sch. On Off)	R/W	197	Register	1069	I069	
70	Saturday on minute (A) (Sch. On Off)	R/W	198	Register	1070	I070	
71	Sunday on hour (A) (Sch. On Off)	R/W	199	Register	1071	I071	
72	Sunday on minute (A) (Sch. On Off)	R/W	200	Register	1072	I072	
73	Rotation hour (automatic rotation)	R/W	201	Register	1073	I073	
74	Discharge pressure 3	R	202	Register	1074	I074	
75	Unit 1 rotation configuration	R/W	203	Register	1075	I075	refer Note Integer Var.
76	Unit 2 rotation configuration	R/W	204	Register	1076	I076	refer Note Integer Var.
77	Unit 3 rotation configuration	R/W	205	Register	1077	I077	refer Note Integer Var.
78	Unit 4 rotation configuration	R/W	206	Register	1078	I078	refer Note Integer Var.
79	Unit 5 rotation configuration	R/W	207	Register	1079	I079	refer Note Integer Var.
80	Unit 6 rotation configuration	R/W	208	Register	1080	I080	refer Note Integer Var.
81	Unit 7 rotation configuration	R/W	209	Register	1081	I081	refer Note Integer Var.
82	Unit 8 rotation configuration	R/W	210	Register	1082	I082	refer Note Integer Var.
83	No. of stand-by units	R/W	211	Register	1083	I083	
85	Monday off hour (B) (Sch. On Off)	R/W	213	Register	1085	I085	
86	Monday off minute (B) (Sch. On Off)	R/W	214	Register	1086	I086	
87	Tuesday off hour (B) (Sch. On Off)	R/W	215	Register	1087	I087	
88	Tuesday off minute (B) (Sch. On Off)	R/W	216	Register	1088	I088	
89	Wednesday off hour (B) (Sch. On Off)	R/W	217	Register	1089	I089	
90	Wednesday off minute (B) (Sch. On Off)	R/W	218	Register	1090	I090	
91	Thursday off hour (B) (Sch. On Off)	R/W	219	Register	1091	I091	
92	Thursday off minute (B) (Sch. On Off)	R/W	220	Register	1092	I092	
93	Friday off hour (B) (Sch. On Off)	R/W	221	Register	1093	I093	
94	Friday off minute (B) (Sch. On Off)	R/W	222	Register	1094	I094	
95	Saturday off hour (B) (Sch. On Off)	R/W	223	Register	1095	I095	
96	Saturday off minute (B) (Sch. On Off)	R/W	224	Register	1096	I096	
97	Sunday off hour (B) (Sch. On Off)	R/W	225	Register	1097	I097	
98	Sunday off minute (B) (Sch. On Off)	R/W	226	Register	1098	I098	
99	Monday on hour (B) (Sch. On Off)	R/W	227	Register	1099	I099	
100	Monday on minute (B) (Sch. On Off)	R/W	228	Register	1100	I100	
101	Tuesday on hour (B) (Sch. On Off)	R/W	229	Register	1101	I101	
102	Tuesday on minute (B) (Sch. On Off)	R/W	230	Register	1102	I102	
103	Wednesday on hour (B) (Sch. On Off)	R/W	231	Register	1103	I103	
104	Wednesday on minute (B) (Sch. On Off)	R/W	232	Register	1104	I104	
105	Thursday on hour (B) (Sch. On Off)	R/W	233	Register	1105	I105	
106	Thursday on minute (B) (Sch. On Off)	R/W	234	Register	1106	I106	
107	Friday on hour (B) (Sch. On Off)	R/W	235	Register	1107	I107	
108	Friday on minute (B) (Sch. On Off)	R/W	236	Register	1108	I108	
109	Saturday on hour (B) (Sch. On Off)	R/W	237	Register	1109	I109	
110	Saturday on minute (B) (Sch. On Off)	R/W	238	Register	1110	I110	
111	Sunday on hour (B) (Sch. On Off)	R/W	239	Register	1111	I111	
112	Sunday on minute (B) (Sch. On Off)	R/W	240	Register	1112	I112	
113	Air flow failed alarm delay time (s)	R/W	241	Register	1113	I113	
114	Stage delay for PID control (s)	R/W	242	Register	1114	I114	
115	Discharge pressure 1	R	243	Register	1115	I115	
116	Discharge pressure 2	R	244	Register	1116	I116	
118	Enable remote on/off	R/W	246	Register	1118	I118	

BMS – VARIABLE LIST

C. ANALOGUE VARIABLE

CITEC		MODBUS			BACnet		Remark
Address	Description	Type	Address	Type	Obj. Inst.	Obj. Name	
1	Dehum. Demand	R	1	Register	1	A001	
2	Return air humidity	R	2	Register	2	A002	
3	Return air temperature	R	3	Register	3	A003	
4	Cooling demand	R	4	Register	4	A004	
5	Heating demand	R	5	Register	5	A005	
6	Humidify demand	R	6	Register	6	A006	
7	Cooling dead zone	R/W	7	Register	7	A007	
8	% of cooling to enable dehum	R/W	8	Register	8	A008	
9	Cooling proportional band	R/W	9	Register	9	A009	
10	Dehum dead zone	R/W	10	Register	10	A010	
11	Valve opening when dehum	R/W	11	Register	11	A011	
12	Dehum proportional band	R/W	12	Register	12	A012	
13	Heating dead zone	R/W	13	Register	13	A013	
14	Heating proportional band	R/W	14	Register	14	A014	
15	Humidity alarm band	R/W	15	Register	15	A015	
16	Return air humidity calibration	R/W	16	Register	16	A016	
17	Retrun air temperature calibration	R/W	17	Register	17	A017	
18	Humidity set point	R/W	18	Register	18	A018	
19	Temperature set point	R/W	19	Register	19	A019	
20	Temperature alarm band	R/W	20	Register	20	A020	
21	Water in temperature (oC)	R	21	Register	21	A021	
22	CW Valve Opening (%)	R	22	Register	22	A022	
23	Humidity dead zone	R/W	23	Register	23	A023	
24	Humidity proportional band	R/W	24	Register	24	A024	
25	Steam production (kg/h)	R	25	Register	25	A025	
26	Current (A)	R	26	Register	26	A026	
29	Water out temperature (oC)	R	29	Register	29	A029	
30	Differential temperature (oC)	R/W	30	Register	30	A030	

Remark:

The BMS variable list is applicable to software version CGDx-3.22 onwards.

BMS – VARIABLE LIST

NOTE FOR INTEGER VARIABLE

Address	Integer	Description
5	0	History deleted
	1	Comp. 1 high pressure trip
	2	Comp. 2 high pressure trip
	3	Comp. 1 low pressure trip
	4	Comp. 2 low pressure trip
	5	High temp.
	6	Low temp.
	7	High humidity
	8	Low humidity
	9	Filter blocked
	10	Klixon tripped
	11	Airflow failed
	12	Water on floor
	13	Drip tray full
	14	Auxilliary alarm 1
	15	Auxilliary alarm 2
	16	Auxilliary alarm 3
	17	High conductivity alarm
	18	High conductivity warning
	19	High current
	20	Low current
	21	Lack water
	22	Low production
	23	Drain alarm
	24	Cylinder full
	25	Pre-exhaustion cylinder
	26	Foam presence
	27	Exhaustion cylinder
	28	Cylinder Maint. Mandatory
	29	Cylinder Maint. Recommended
	30	LAN Error
	31	Unit health check
	32	Unit run expired
	33	Water in high temp.
	34	Aalarm high disch. P1
	35	Aalarm high disch. P2
	36	Warning high disch. P1
	37	Warning high disch. P2
	38	Alarm RAT sensor failed
	39	Alarm RAH sensor failed
	40	Pressure probe 1 failed
	41	Pressure probe 2 failed
	42	Unit off alarm
	43	Clock board error
	44	Anti freeze 1 tripped
	45	Anti freeze 2 tripped
	46	Water in sensor failed
	47	Water out sensor failed
	48	Coil temp.1 sensor failed
	49	Coil temp.2 sensor failed
	50	Return air humidity sensor out of range
	51	Eeprom Error (EEV D1)

Address	Integer	Description
5	52	Eeprom Error (EEV D2)
	53	Eeprom Error (EEV D3)
	54	EEV Motor Error (D1)
	55	EEV Motor Error (D2)
	56	EEV Motor Error (D3)
	57	MOP Time Out (EEV D1)
	58	MOP Time Out (EEV D2)
	59	MOP Time Out (EEV D3)
	60	LOP Time Out (EEV D1)
	61	LOP Time Out (EEV D2)
	62	LOP Time Out (EEV D3)
	63	Low Super Heat (EEV D1)
	64	Low Super Heat (EEV D2)
	65	Low Super Heat (EEV D3)
	66	High Super Heat (EEV D1)
	67	High Super Heat (EEV D2)
	68	High Super Heat (EEV D3)
	69	EEV Not Closed During Power Off (D1)
	70	EEV Not Closed During Power Off (D2)
	71	EEV Not Closed During Power Off (D3)
	72	Probe S1 Error (EEV D1)
	73	Probe S1 Error (EEV D2)
	74	Probe S1 Error (EEV D3)
	75	Probe S3 Error (EEV D1)
	76	Probe S3 Error (EEV D2)
	77	Probe S3 Error (EEV D3)
	78	LAN Disconnected (EEV D1)
	79	LAN Disconnected (EEV D2)
	80	LAN Disconnected (EEV D3)
	81	Comp.3 HP Tripped
	82	Comp.3 LP Tripped
	83	Pressure Probe 3 Failed
	84	Alarm High Discharge P3
	85	Warning High Discharge P3
	86	Power Failure *
	87	Power Restore *
	88	Unit Start *
	89	Unit Stop *
	90	Alarm Acknowledge *
15	0	Unit On
	1	Off by alarm
	2	Off by supervisory
	3	Off by schedule
	4	Off by remote input
	5	Off by keyboard
	6	Manual procedure
	7	Standby
44	0	Automatic rotation
	1	Timezones rotation
75-82	0	Present/Rotation
	1	Present/No Rotation
	2	Absent

* : alarm log can be enabled/disabled at Level 2 -> Alarm Setup